

**271, 272, 273,  
274**

Teileliste und Näheinrichtungen  
Parts List and Sewing Equipment

Alle Rechte vorbehalten.  
Eigentum der Dürkopp Adler GmbH und urheberrechtlich geschützt. Jede  
Wiederverwendung dieser Inhalte, auch in Form von Auszügen, ist ohne vorheriges  
schriftliches Einverständnis der Dürkopp Adler GmbH verboten.

All rights reserved.  
Property of Dürkopp Adler GmbH and protected by copyright. Any reuse of these contents,  
including extracts, is prohibited without the prior written approval of Dürkopp Adler GmbH.

Copyright © Dürkopp Adler GmbH 2025

Teileliste und Näheinrichtungen  
 Parts List and Sewing Equipment  
 271, 272, 273, 274

Inhaltsverzeichnis/Table of Contents

Inhalt	Tafel/Table	Content
271-140331 und 271-140332	1-4, 6-13, 16, 17	271-140331 and 271-140332
271-140341	5	271-140341
271-140342	5	271-140342
271-140432	5	271-140432
271-140442	5	271-140442
272-140331	14, 15	272-140331
272-140332	14, 15	272-140332
272-140341	14, 15	272-140341
272-140342	14, 15	272-140342
272-160362	14, 15, 19	272-160362
272-640642	20, 21, 22	272-640642
272-740642	6, 23-25	272-740642
273-140342	5, 6, 26-28	273-140342
273-140432	5, 6, 28	273-140432
274-140342	6, 14, 15, 22, 26, 28	274-140342
Bausatz für 273-140342, 273-140432	29	Kit for 273-140342, 273-140432
Bausatz für 271-140042 274-140342	30	Kit for 271-140042 274-140342
Bedienfeld, Antrieb, Steuerung	15.1	Operating panel, Drive, Control
Greifer	19, 31, 32	Hooks
Gestell	9, 33	Stand
Beipack	34, 35	Accessories
Wartungseinheit	36	Maintenance unit
Nählicht	37, 37.1, 38	Sewing light
Handverriegelung und Fußschalter	39	Manual locking and Foot switch
Restfadenwächter	40	Remaining thread monitor
Fadenwischer	41	Thread wiper
Lichtschranke	42	Light barrier
Elektropneumatischer Fadenwischer	43	Electropneumatical thread wiper
Elektropneumatischer Kantenschneider	44	Electropneumatical edge cutter
Gestuftes Beschneiden	45, 46	Stepped trimming
Absaugeinrichtung	47	Suction device
Multiflex	48, 49, 50	Multiflex
Näheinrichtungen Pläne		Sewing Equipment Plans

CL. 271, 272, 273, 274

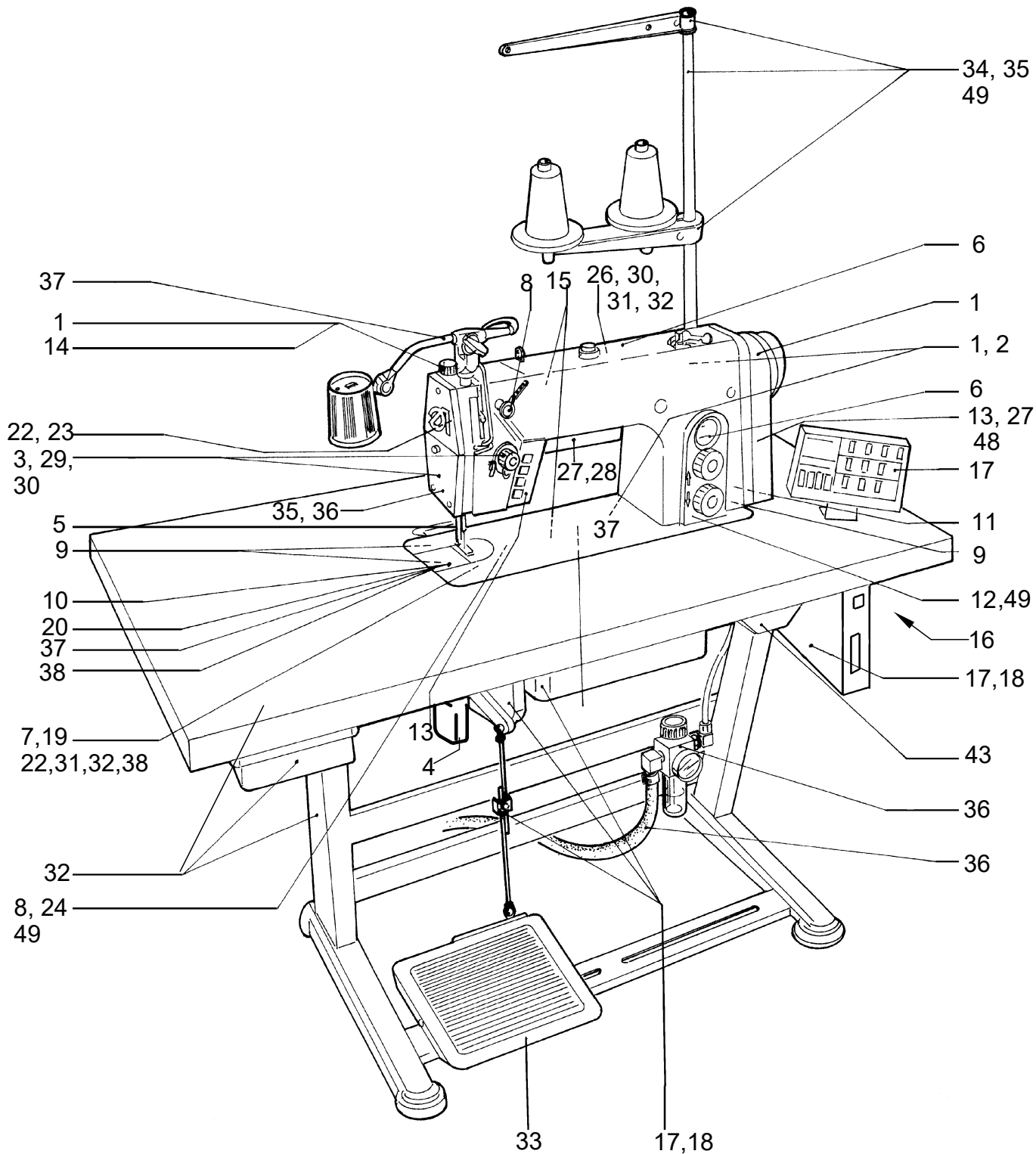

1

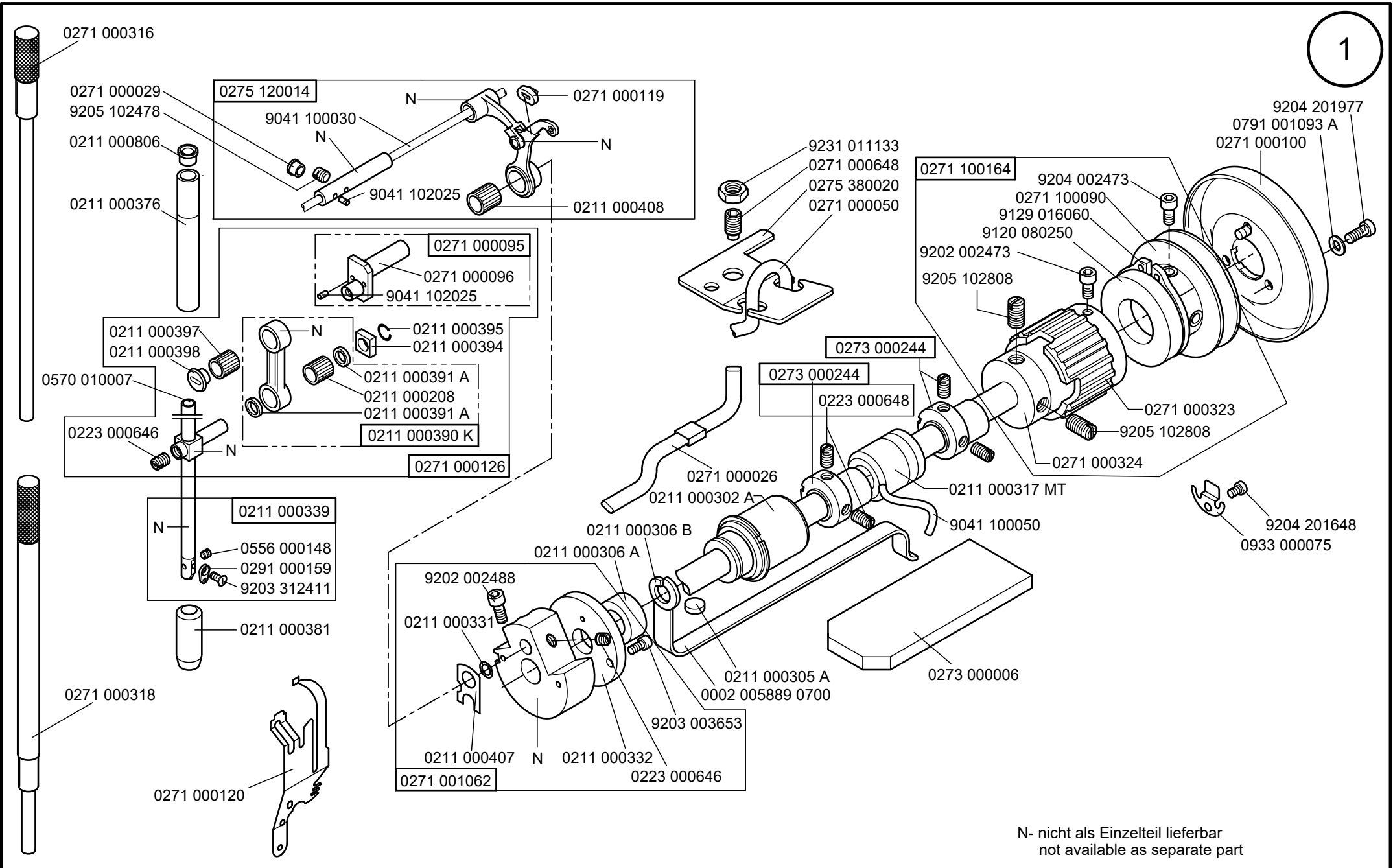

N- nicht als Einzelteil lieferbar  
not available as separate part

Scale 40%

Cl. 271, 272, 273, 274

letzte Änderung/ last change 08.2012  
Ausgabe/ Edition 06.2025

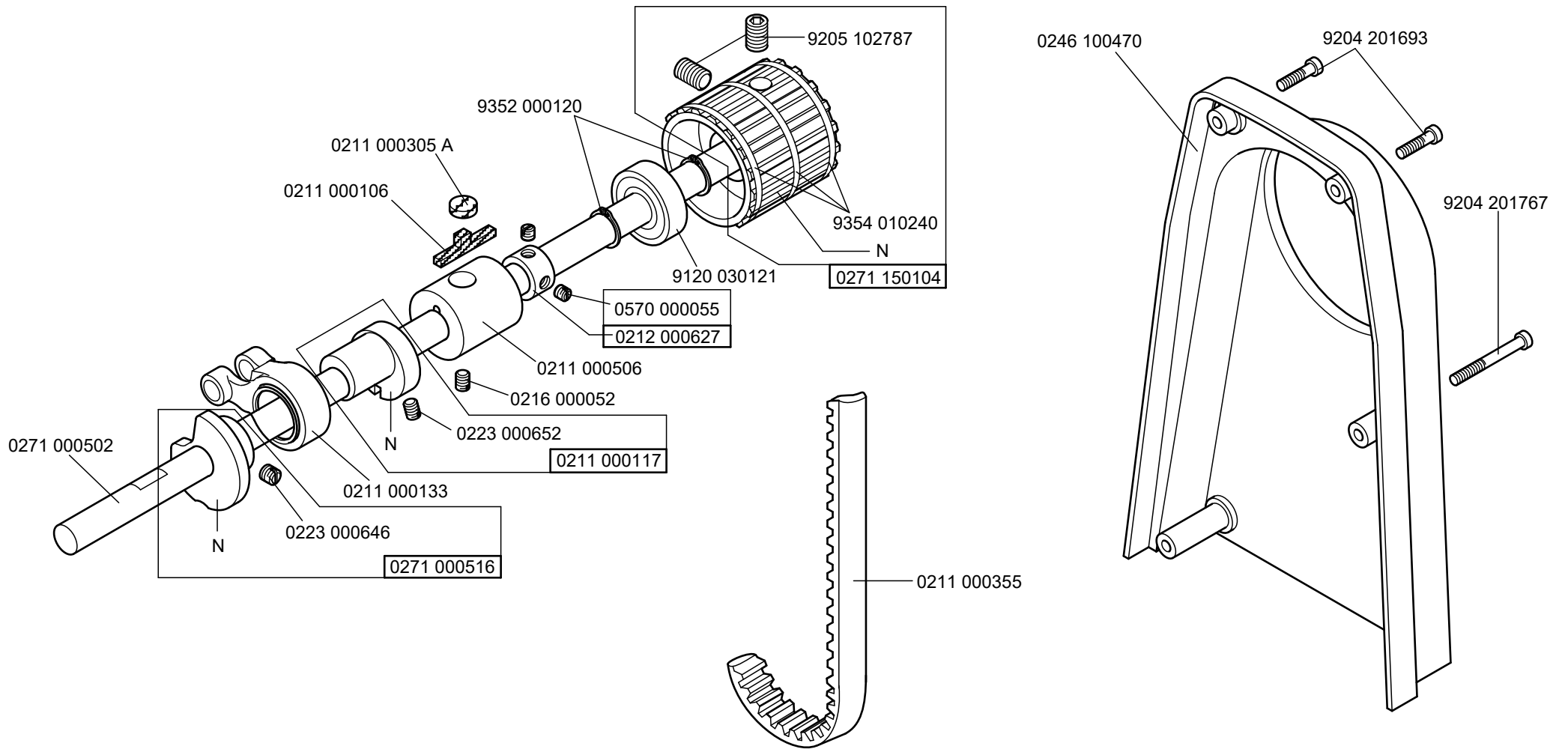

N- nicht als Einzelteil lieferbar  
not available as separate part

Scale 50%

Cl. 271, 272, 273, 274

letzte Änderung/ last change 08.2012  
Ausgabe/ Edition 06.2025

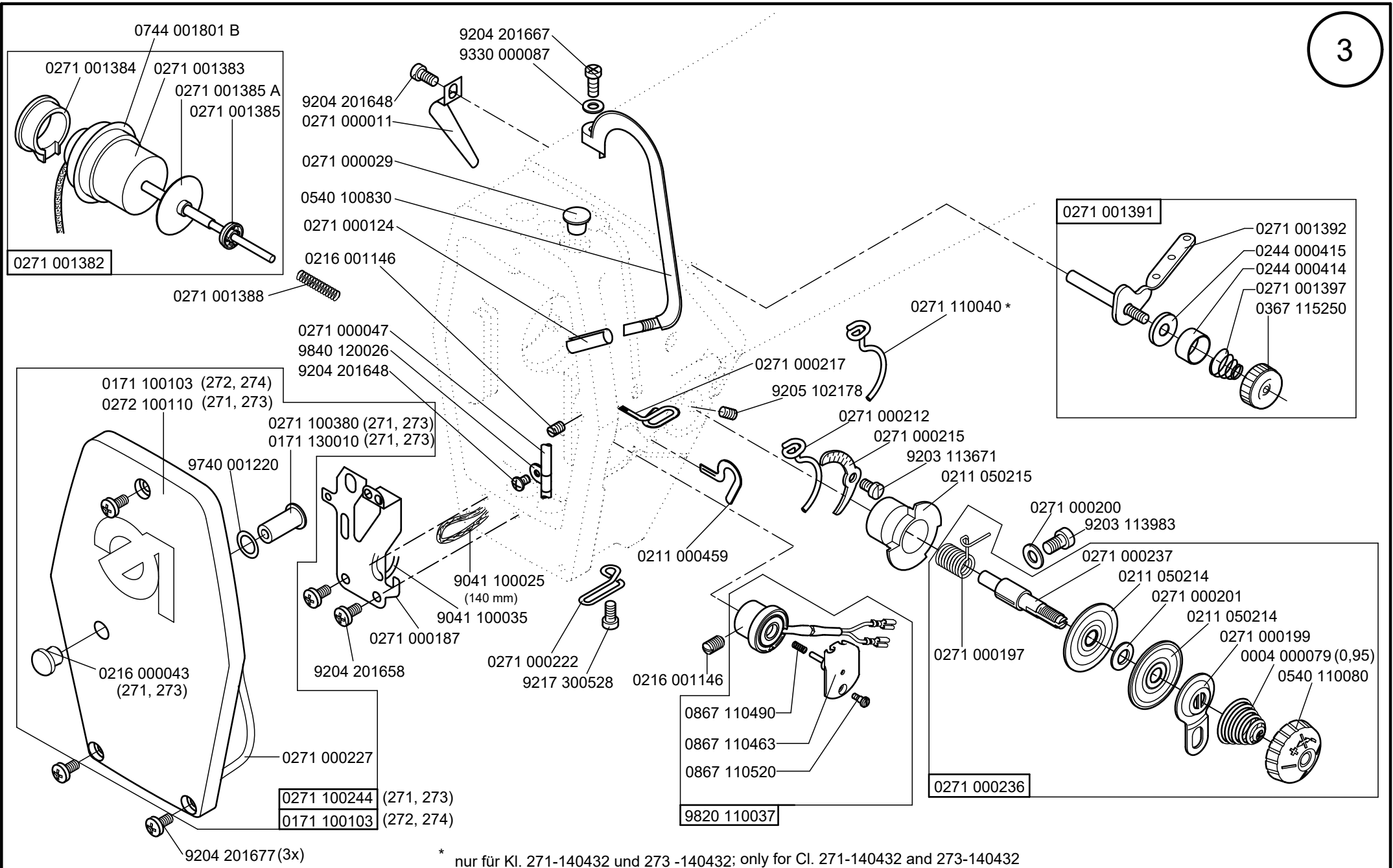

\* nur für Kl. 271-140432 und 273 -140432; only for Cl. 271-140432 and 273-140432

Siehe Tafel 5  
see table 5

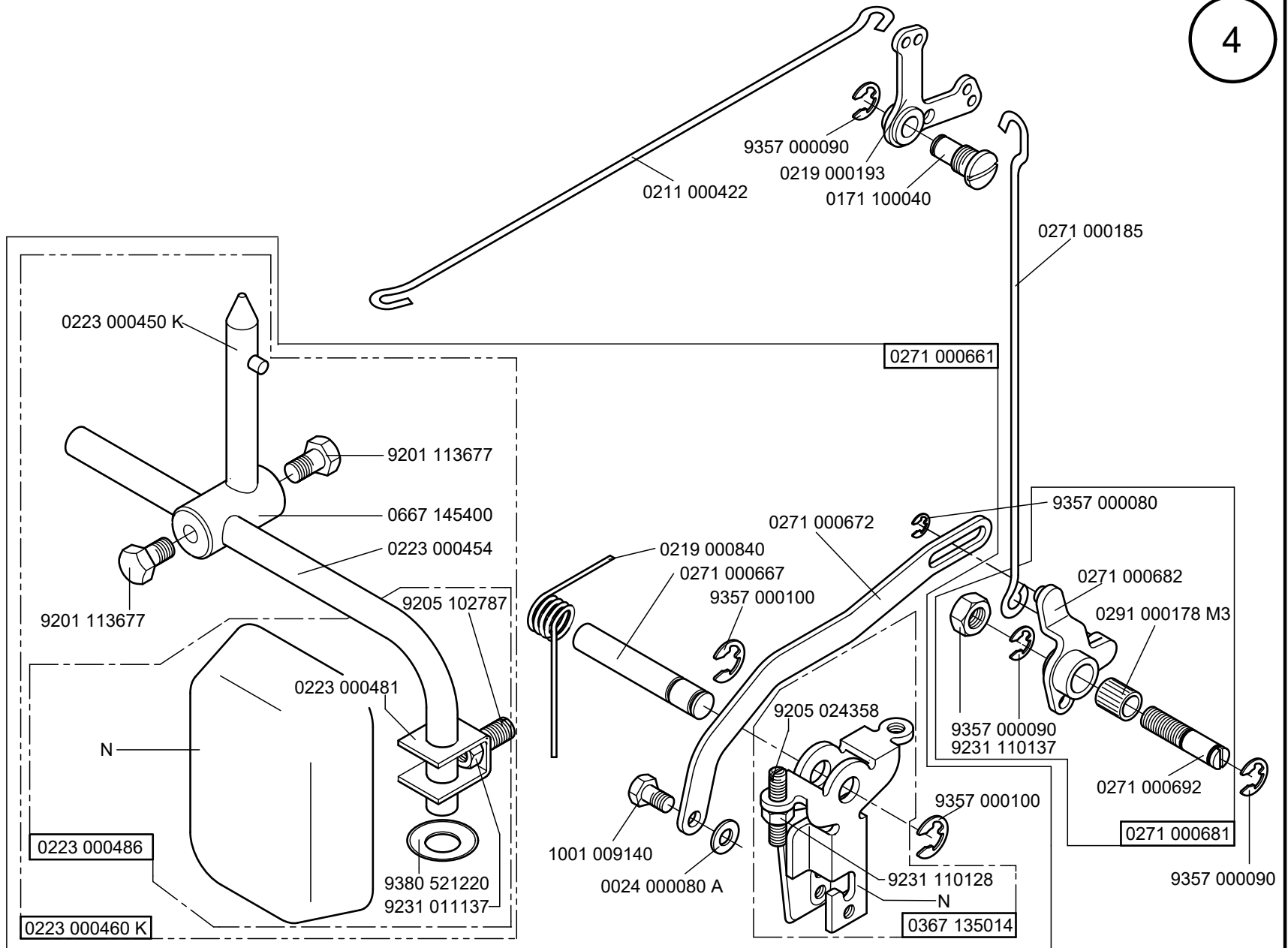

N- nicht als Einzelteil lieferbar  
not available as separate part

\* nur für Kl. 271 und 273; only for cl. 271 and 273

Scale 50%

Cl. 271, 272, 273, 274

letzte Änderung/ last change 03.2011  
Ausgabe/ Edition 06.2025



# Cl. 271, 273

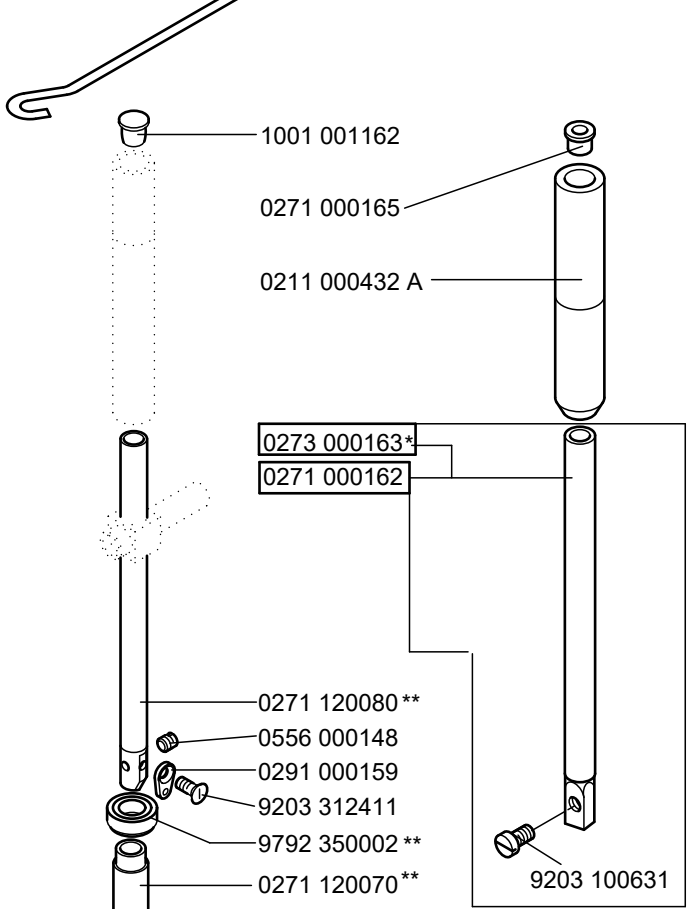
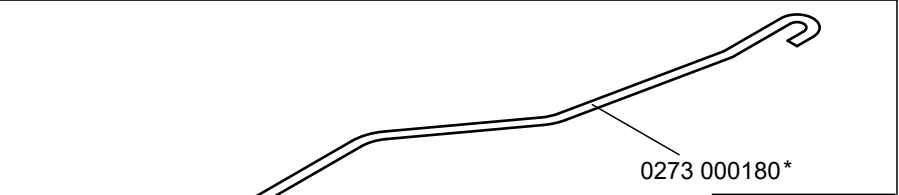

\*nur für Kl. 273-140342  
only for cl. 273-140342

\*\*nur für Kl. 271-140432, -140442, -140332, -140342  
only for cl. 271-140432, -140442, -140332,-140342

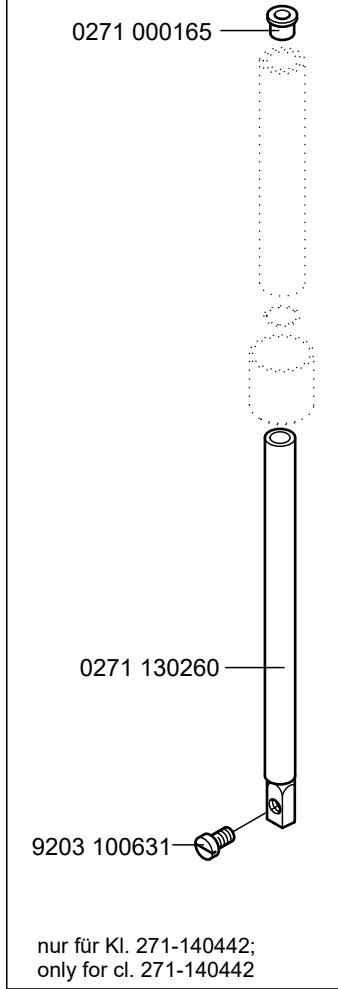

nur für Kl. 271-140442;  
only for cl. 271-140442

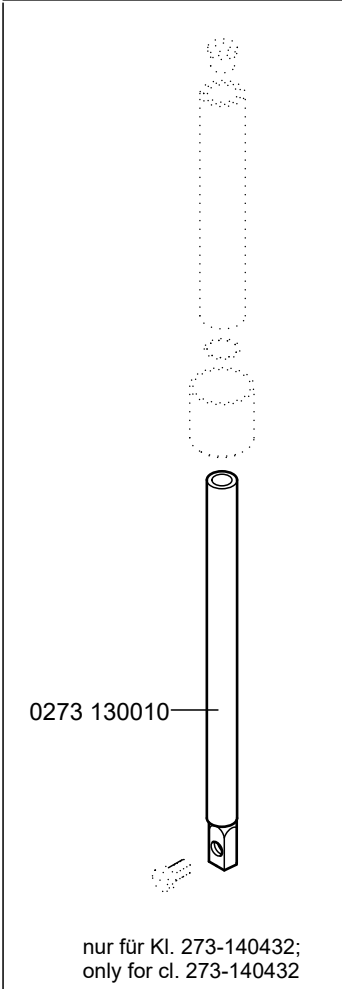

nur für Kl. 273-140432;  
only for cl. 273-140432

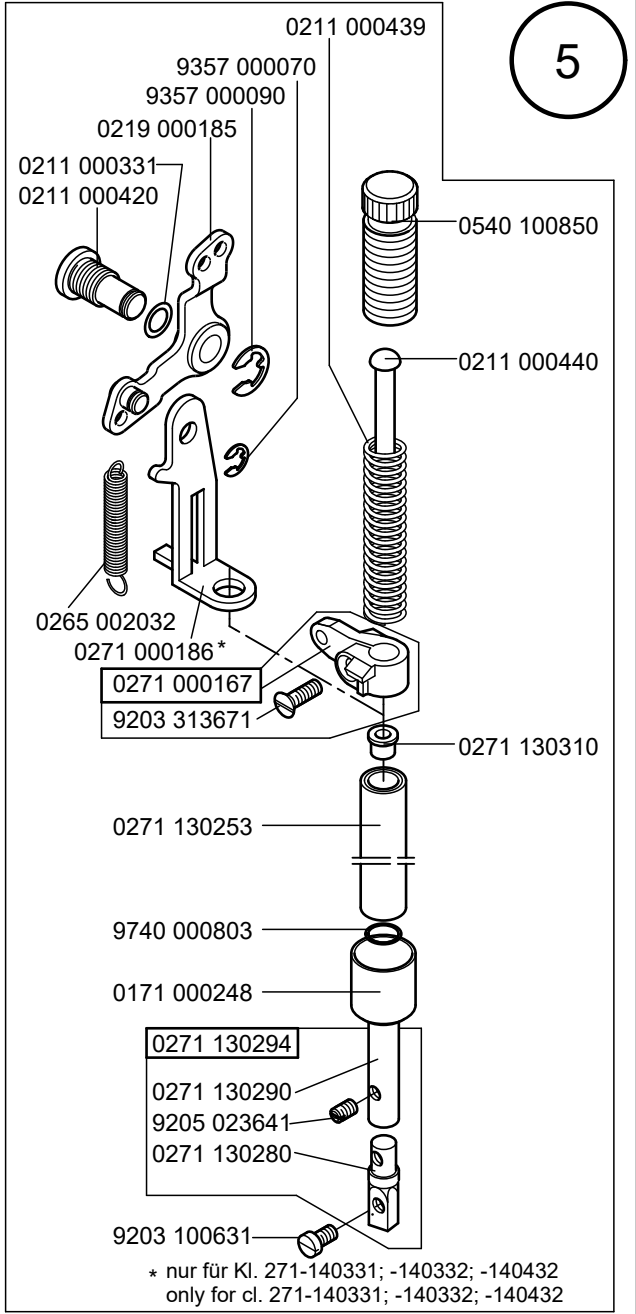

\* nur für Kl. 271-140331; -140332; -140432  
only for cl. 271-140331; -140332; -140432

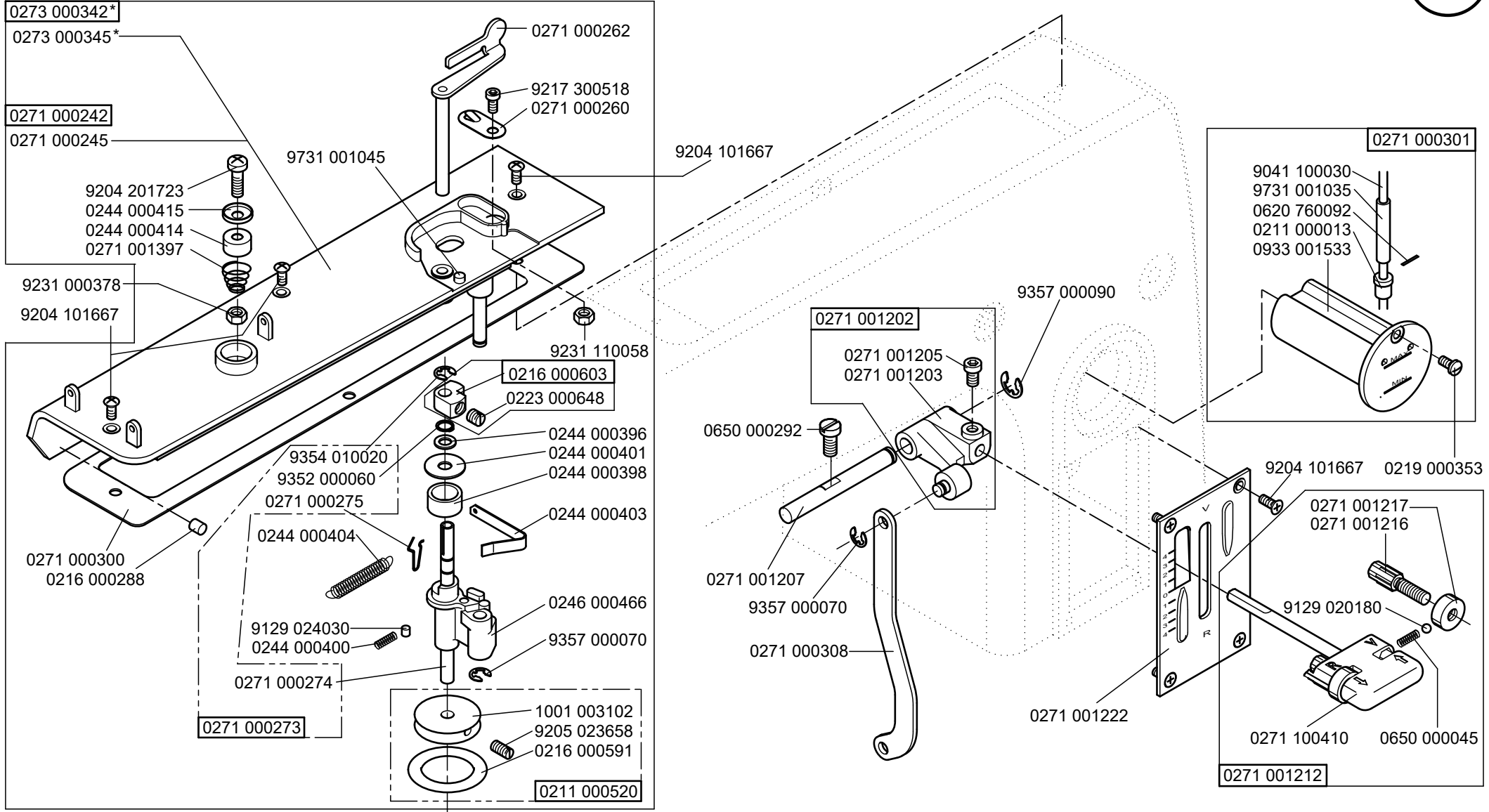

\* nur für Kl. 272-740642, 273-140342, -140432 und 274-140342; only for cl. 272-740642, 273-140342, -140432 and 274-140342

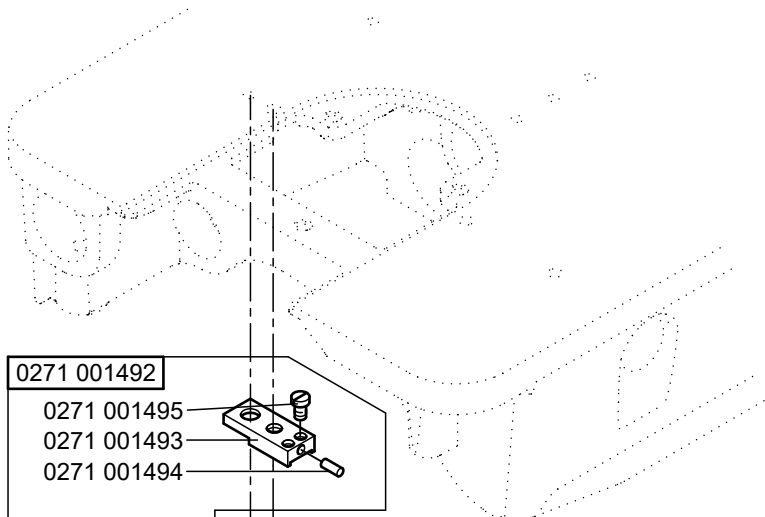

0271 001492

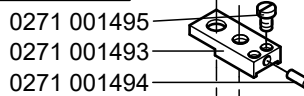

0271 001495  
0271 001493  
0271 001494

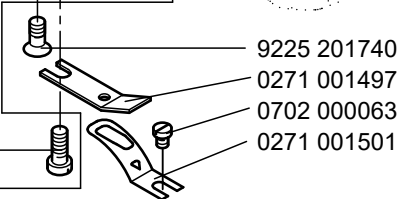

9225 201740  
0271 001497  
0702 000063  
0271 001501

0271 001499

Greifer siehe Tafel 19, 31, 32  
Hook see table 19, 31, 32

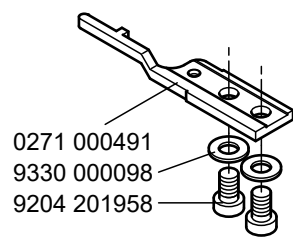

0271 000491  
9330 000098  
9204 201958

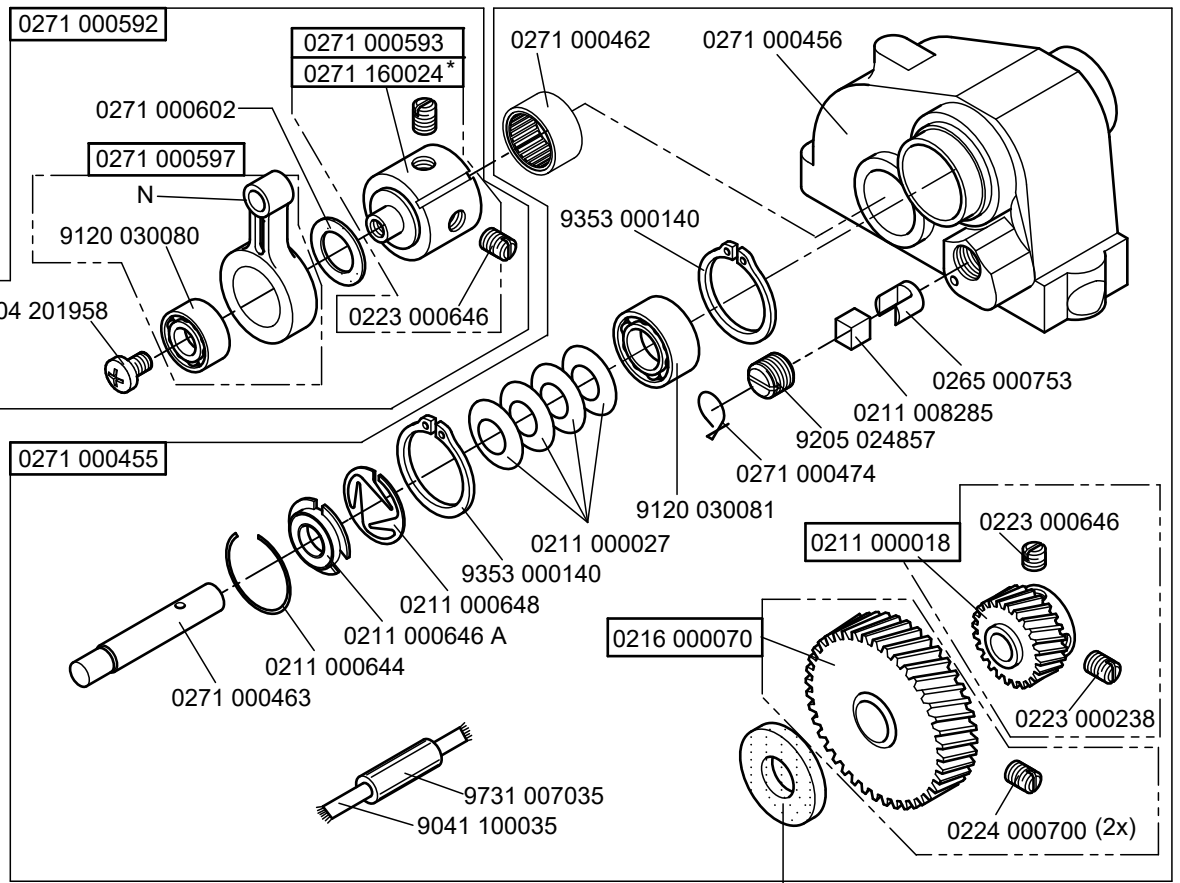

0271 000592

0271 000593  
0271 160024\*

0271 000602

0271 000597

9120 030080

9204 201958

0223 000646

0271 000462

0271 000456

9353 000140

0265 000753

0211 008285

9205 024857

0271 000474

0271 000455

9120 030081

0211 000027

0211 000018

0223 000646

0216 000070

0211 000644

0211 000648

0211 000646 A

0223 000238

0271 000463

9731 007035

9041 100035

0224 000700 (2x)

0211 000022

N- nicht als Einzelteil lieferbar  
not available as separate part

\* nur für Kl. 273-140432; only for Cl. 273-140432

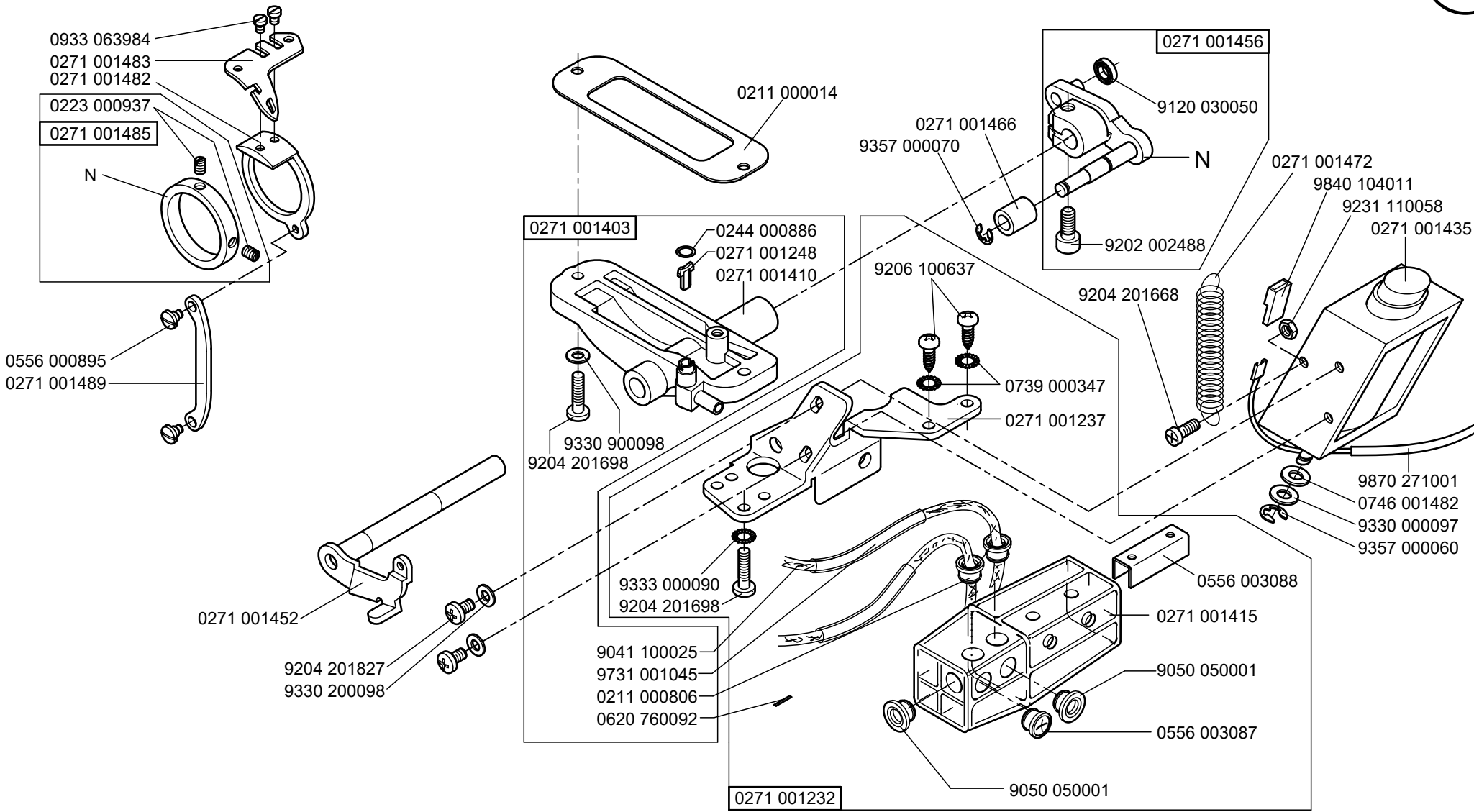

N- nicht als Einzelteil lieferbar  
not available as separate part

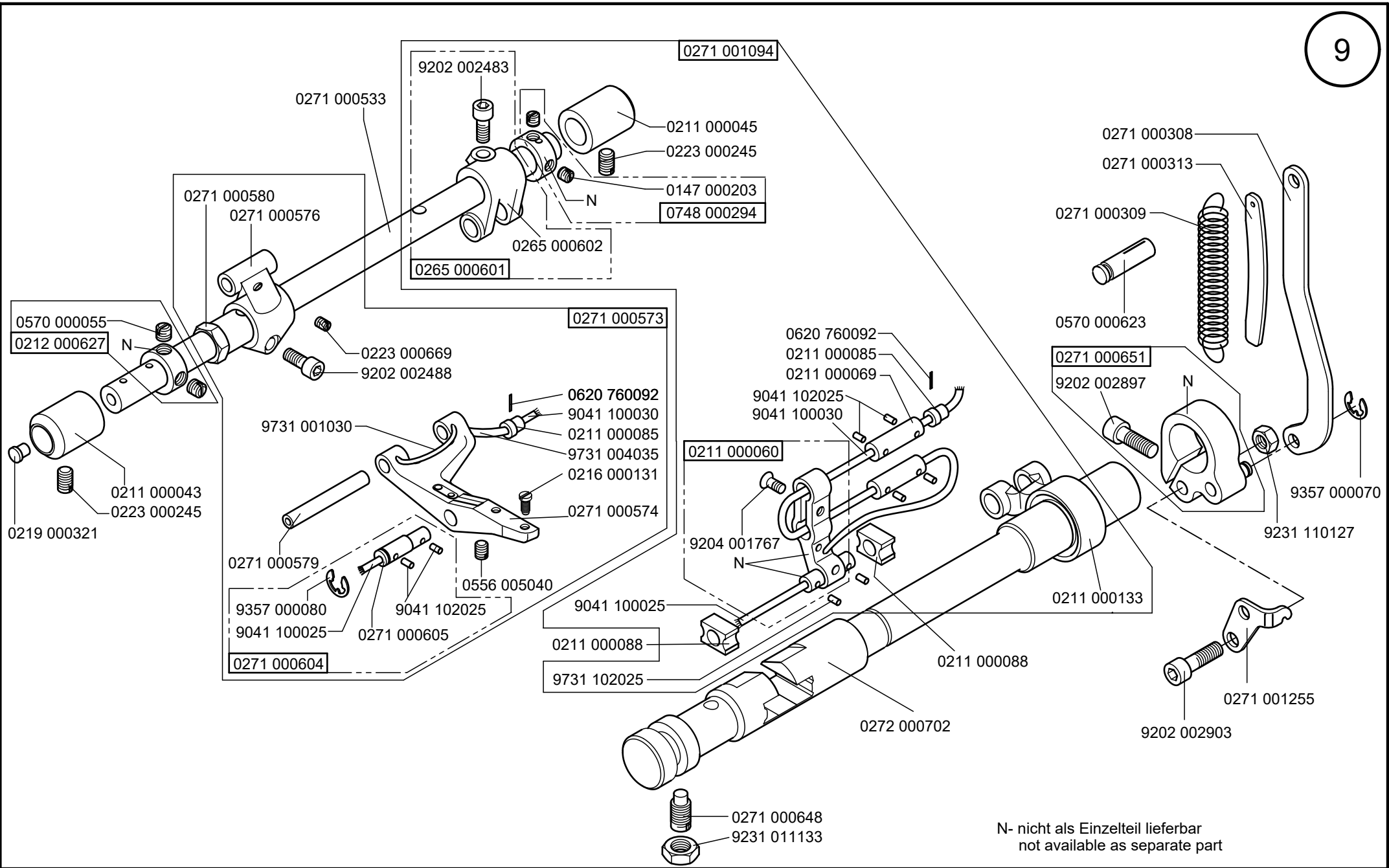

N- nicht als Einzelteil lieferbar  
not available as separate part

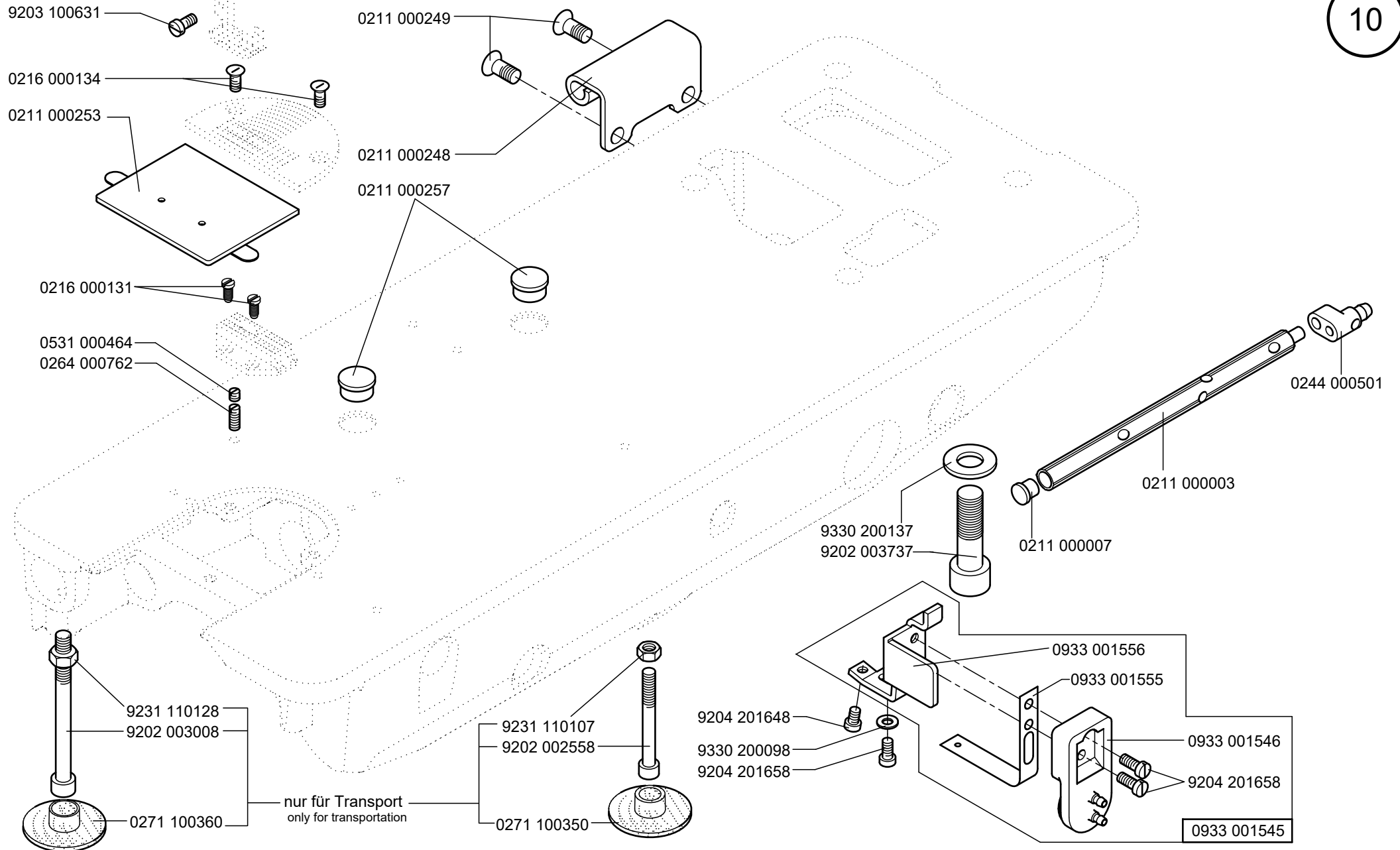

Scale 50%

Cl. 271, 272, 273, 274

letzte Änderung/ last change 01.2011  
Ausgabe/ Edition 06.2025

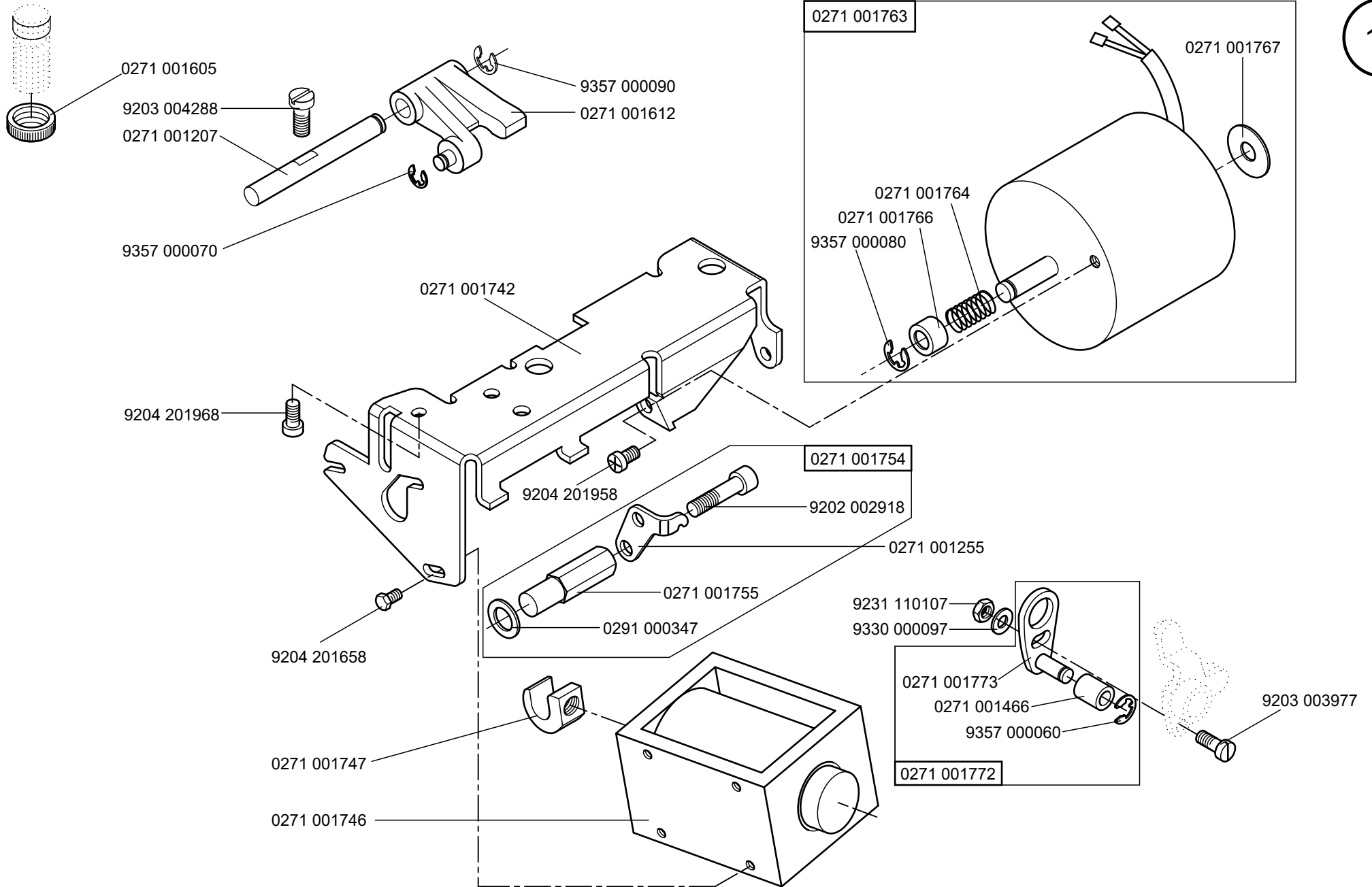

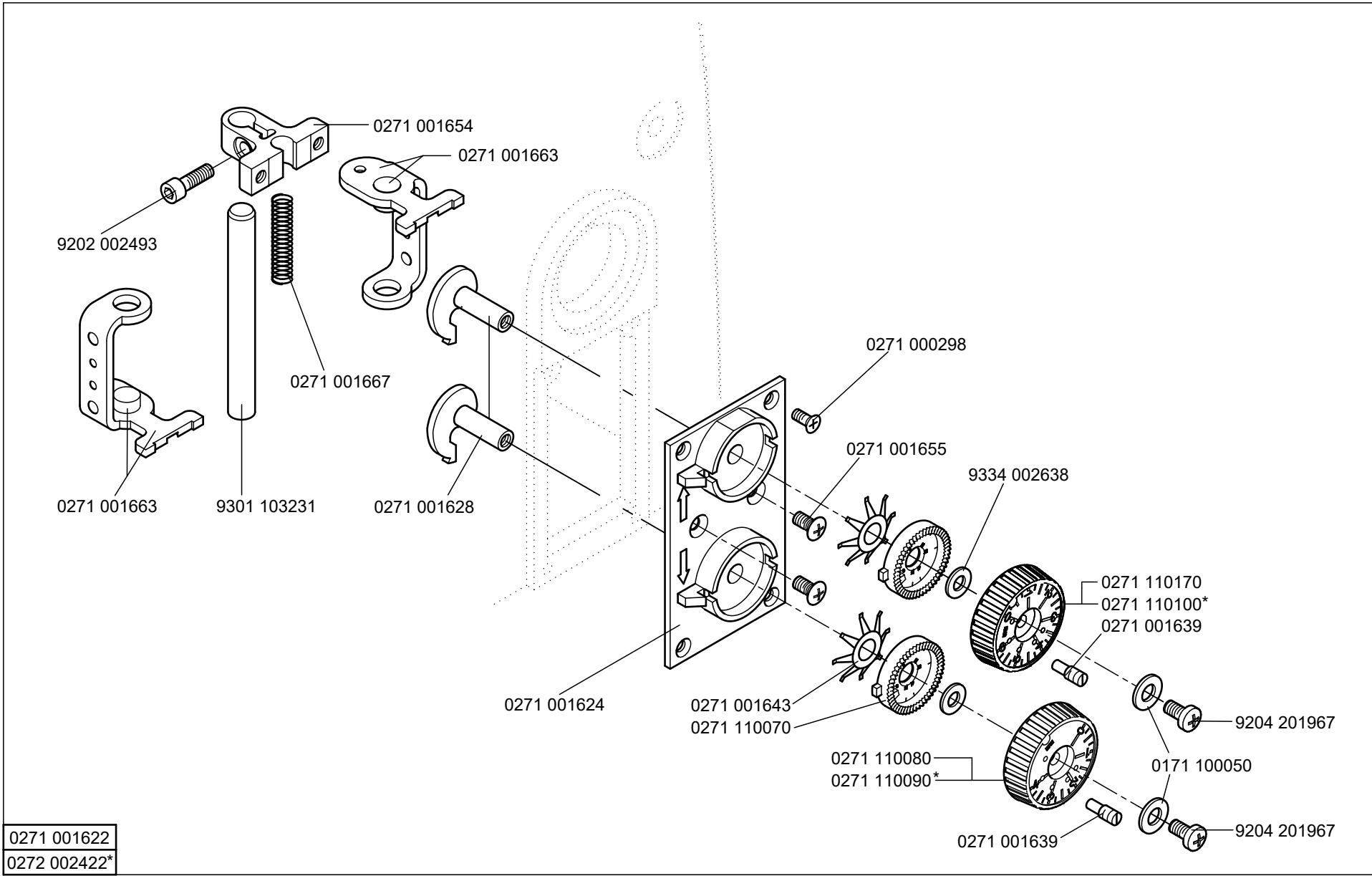

\* nur für Kl. 272-160362; only for Cl. 272-160362



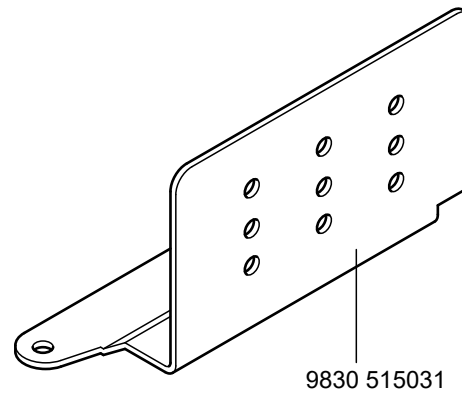
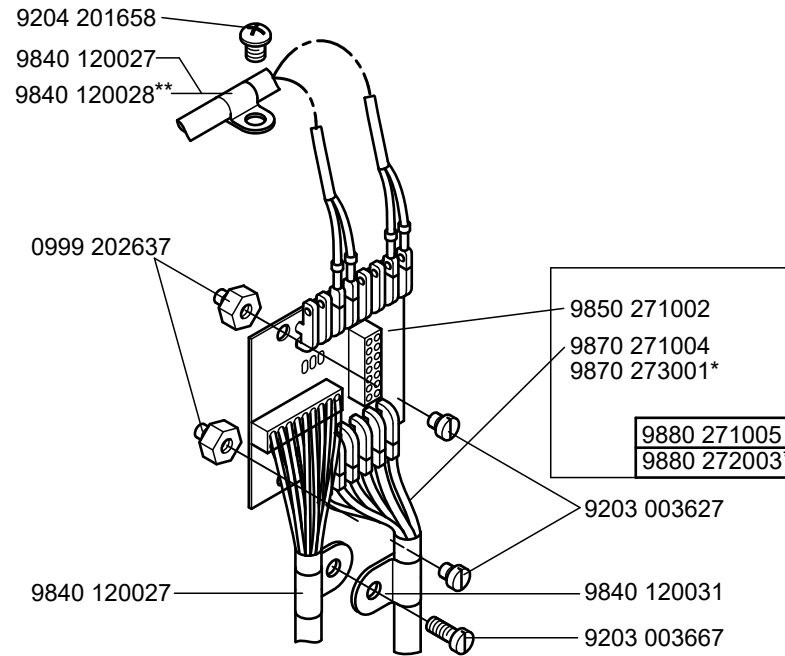
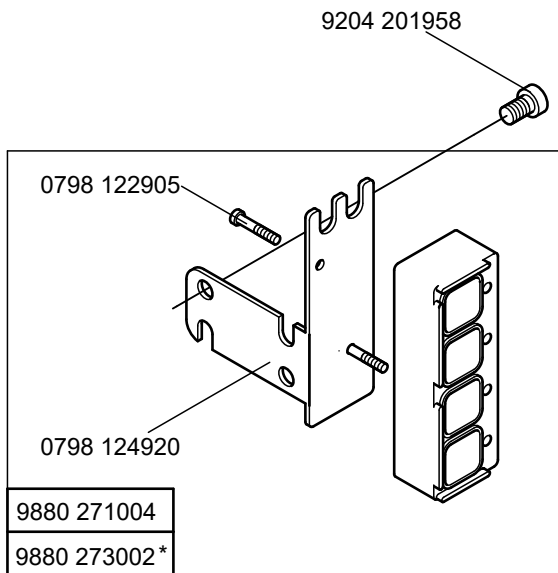

\* nur für Kl. 273-140342, -140432 und 274-140342; only for Cl. 273-140342, -140432 and 274-140342

\*\* nur für Kl. 272-640642, -740642, 273-140342 und -140432; only for Cl. 272-640642, -740642, 273-140342 und -140432

# Cl. 272, 274

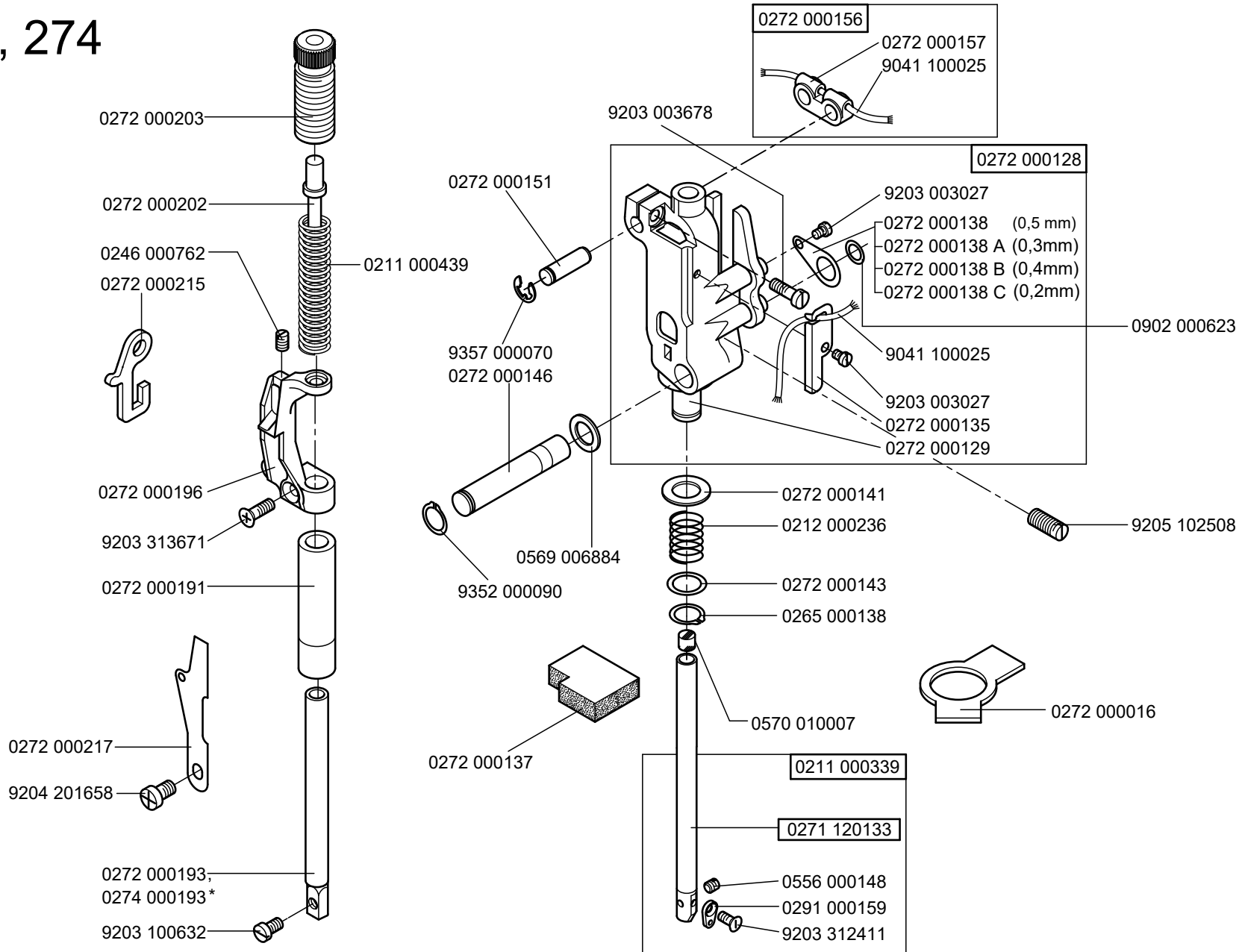

\* nur für Kl. 274-140342; only for Cl. 274-140342

# Cl. 272, 274

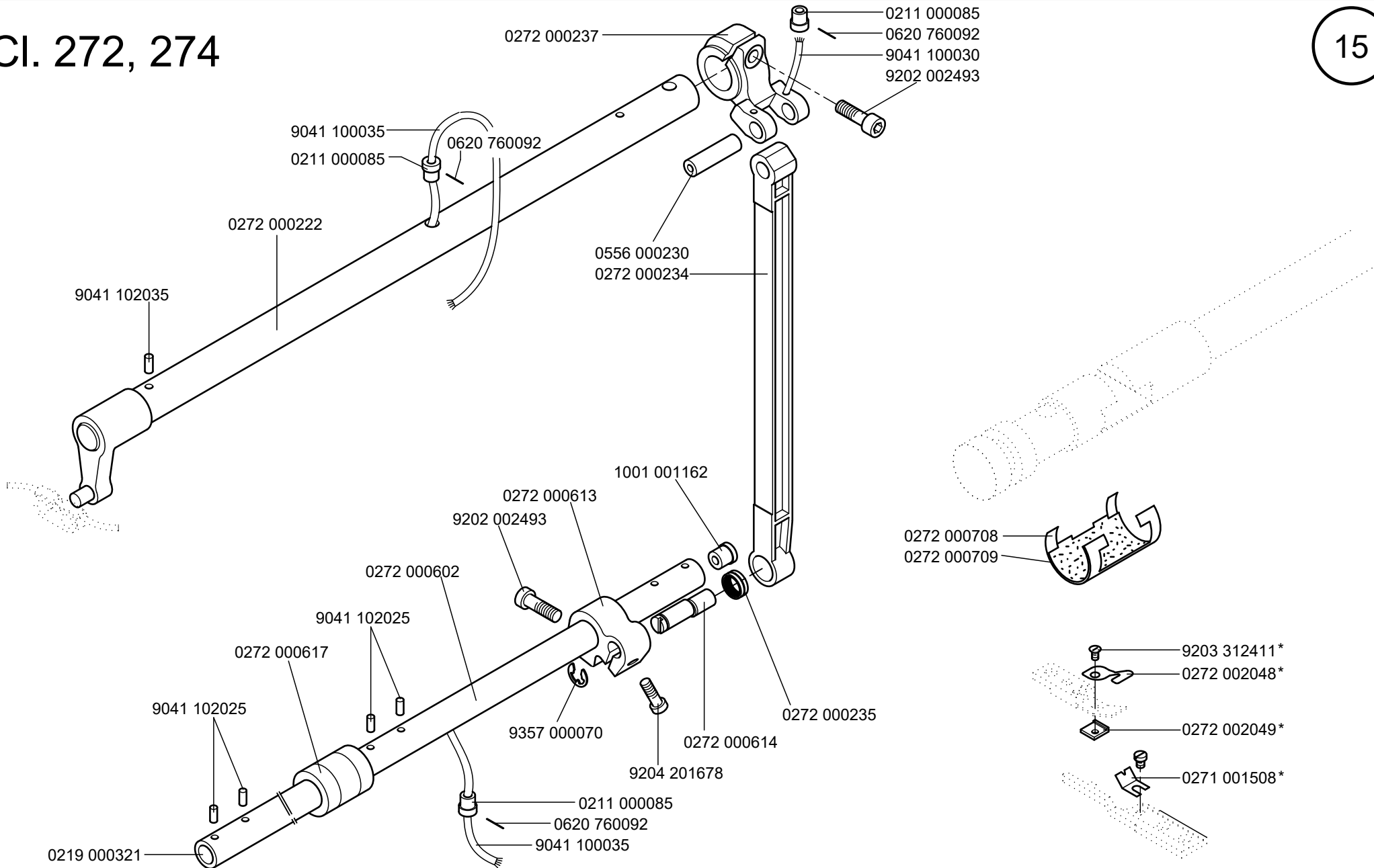

\* nur für Kl. 272-160362; only for cl. 272-160362

Scale 50%

# Cl. 271, 272, 273, 274

letzte Änderung/ last change 03.2009  
 Ausgabe/ Edition 06.2025

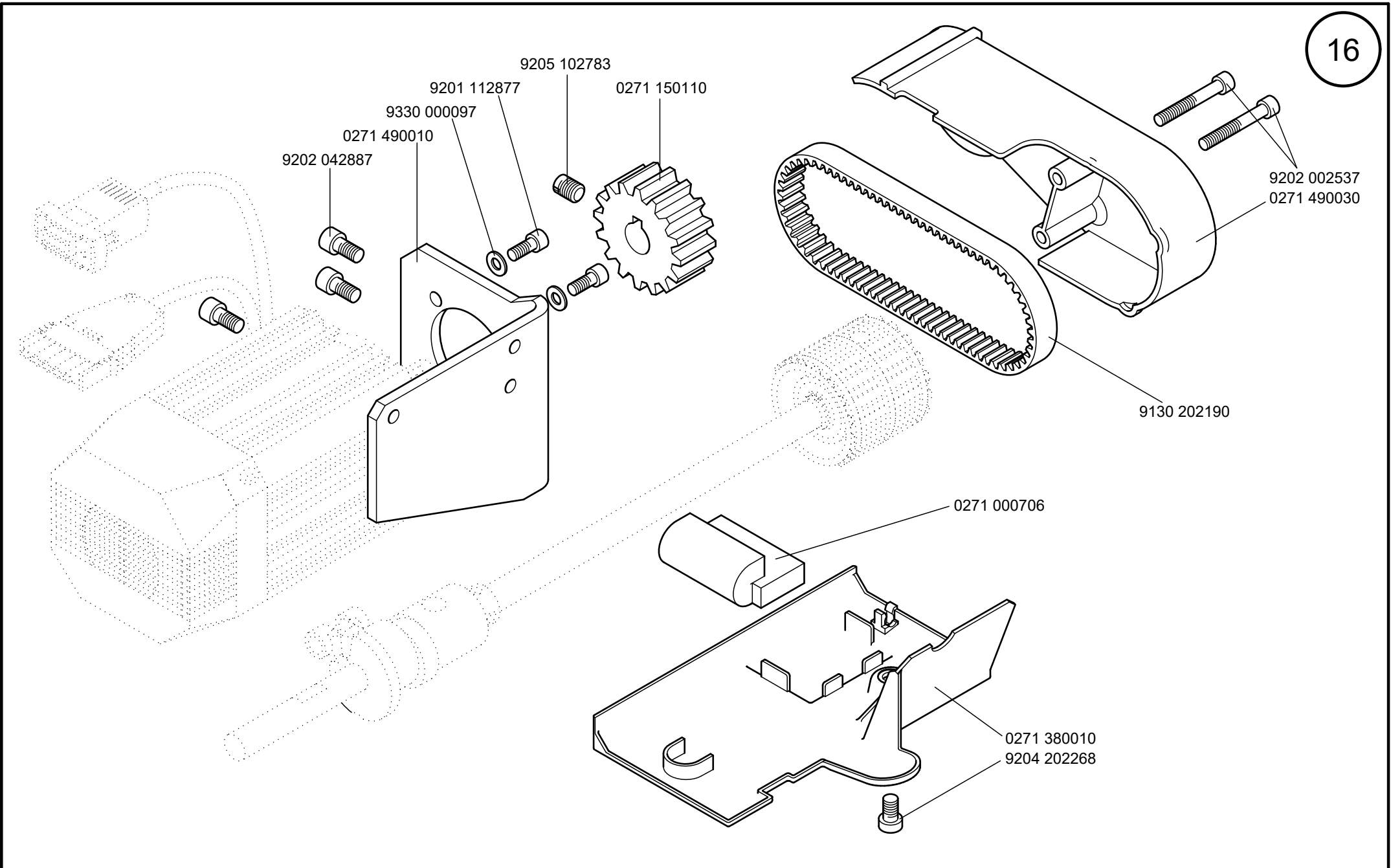

9401 000204

9800 210001 R

DAC classic

9850 001309

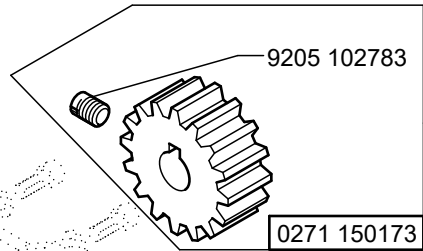
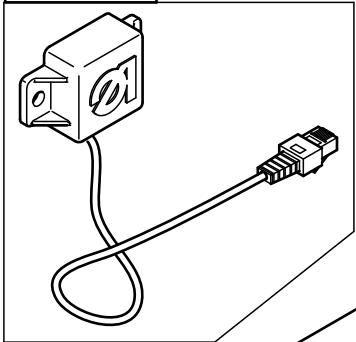

9205 102783

0271 150173

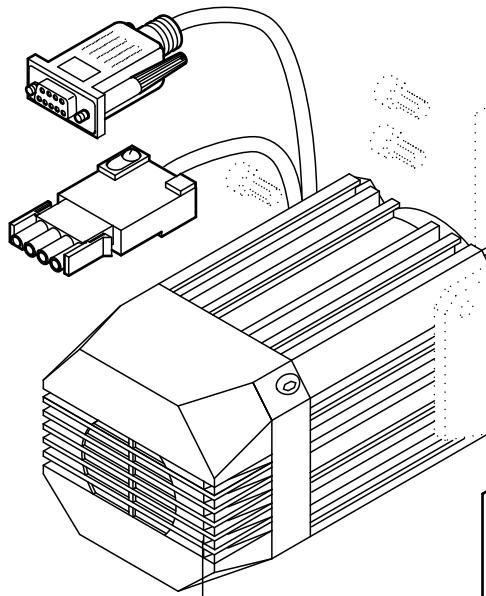
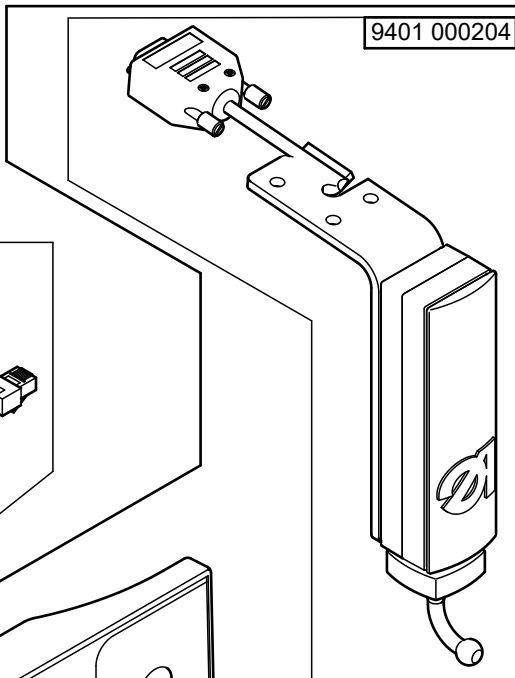

9800 170038

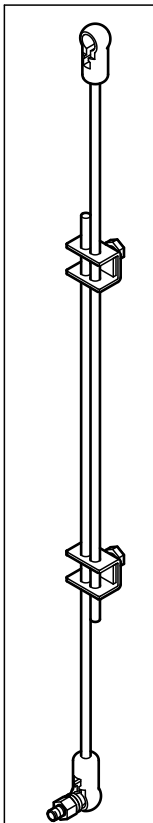

9401 000194

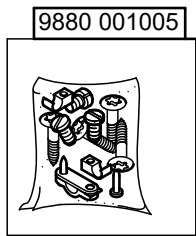

9880 001005

9850 001311

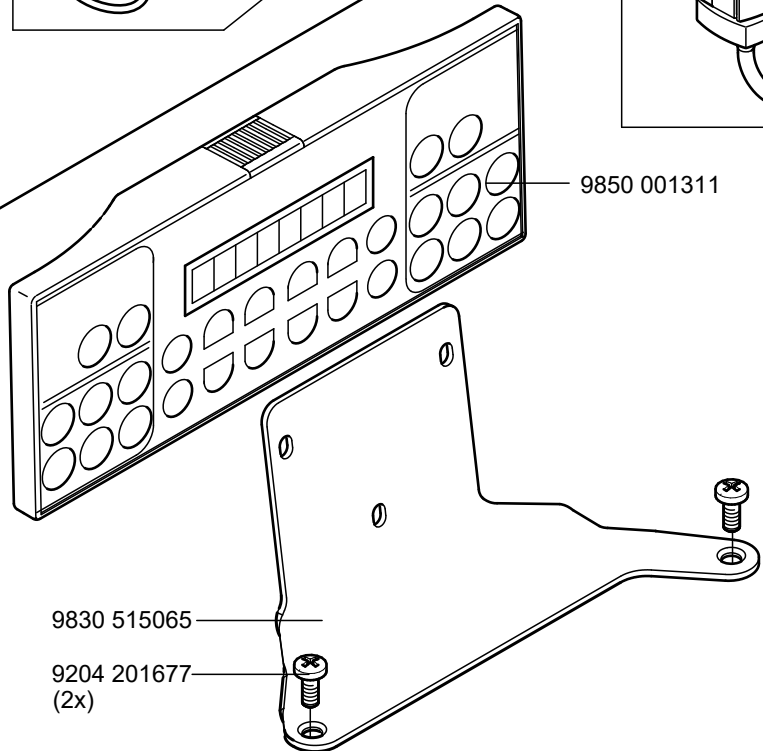

9830 515065

9204 201677 (2x)

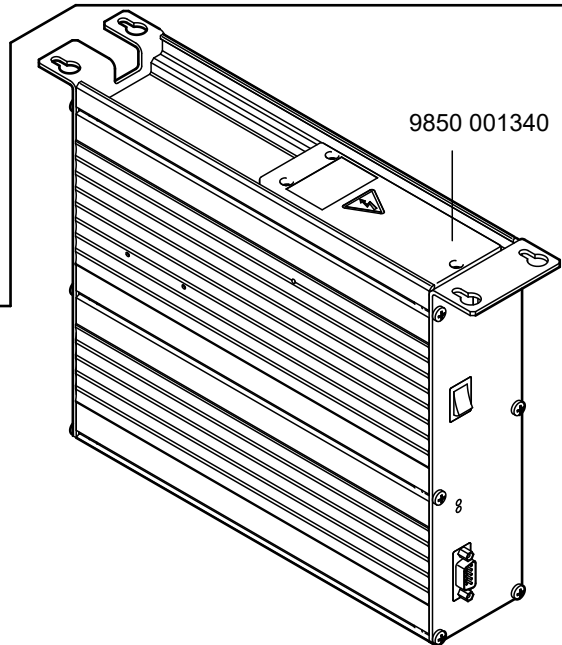

9850 001340

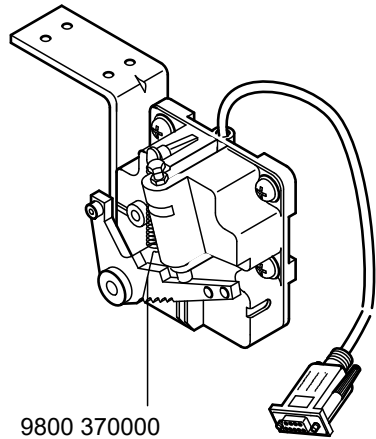

9800 370000

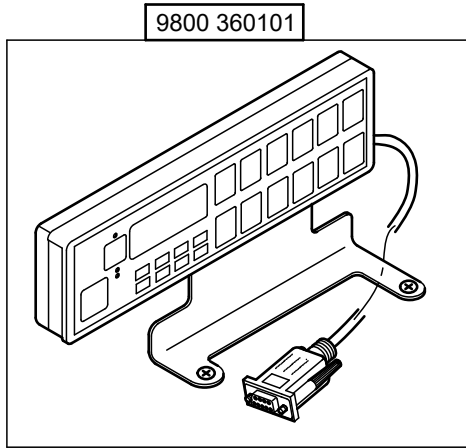

9800 360101

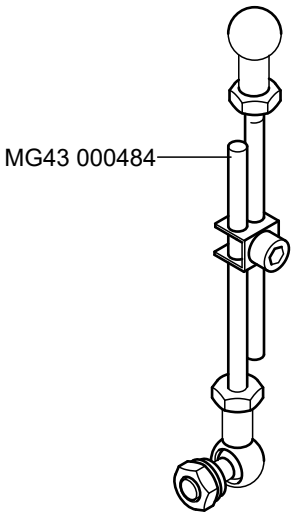

MG43 000484

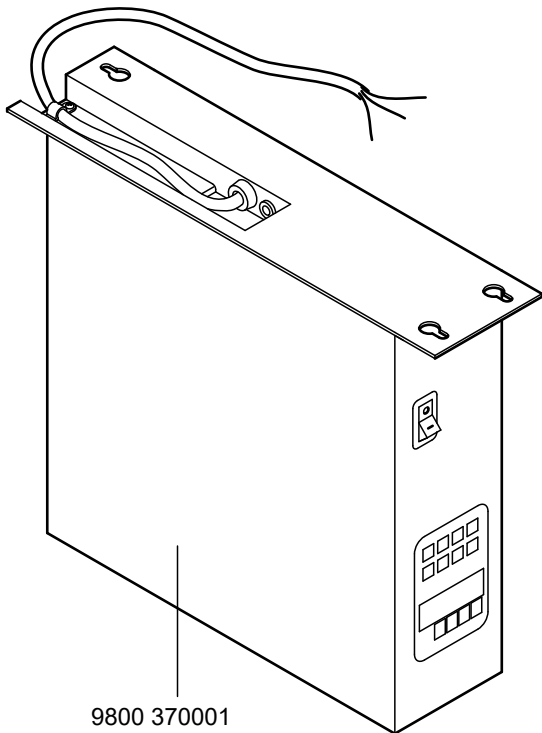

9800 370001

9800 170026 R

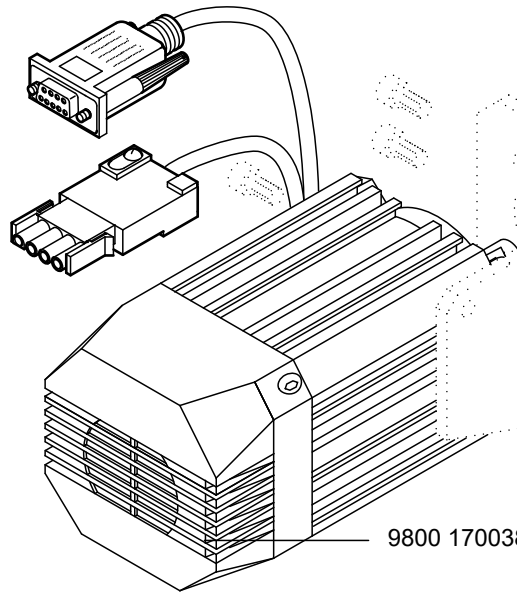

9800 170038

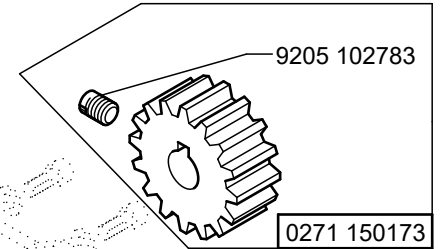

9205 102783

0271 150173

- 9825 810215 (F2,5/250)
- 9825 810409 (T0,6/250V)
- 9825 830223 (F15/250V)

0244 000558

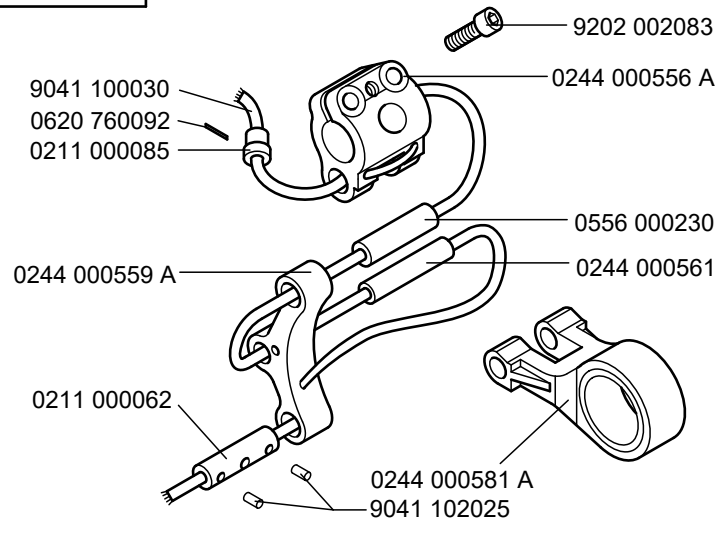

0244 000587 A

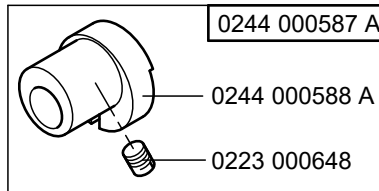

0271 002091

0271 002105

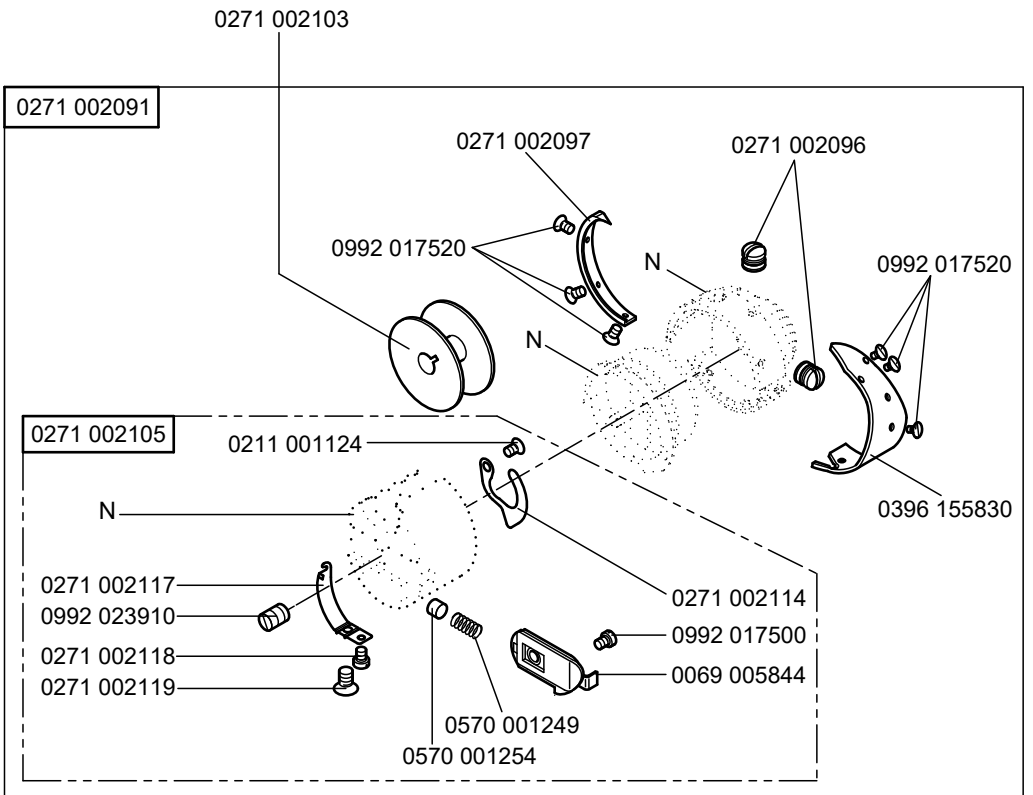

CI. 272 - 640142; -640642  
 CI. 272 - 740142; -740642

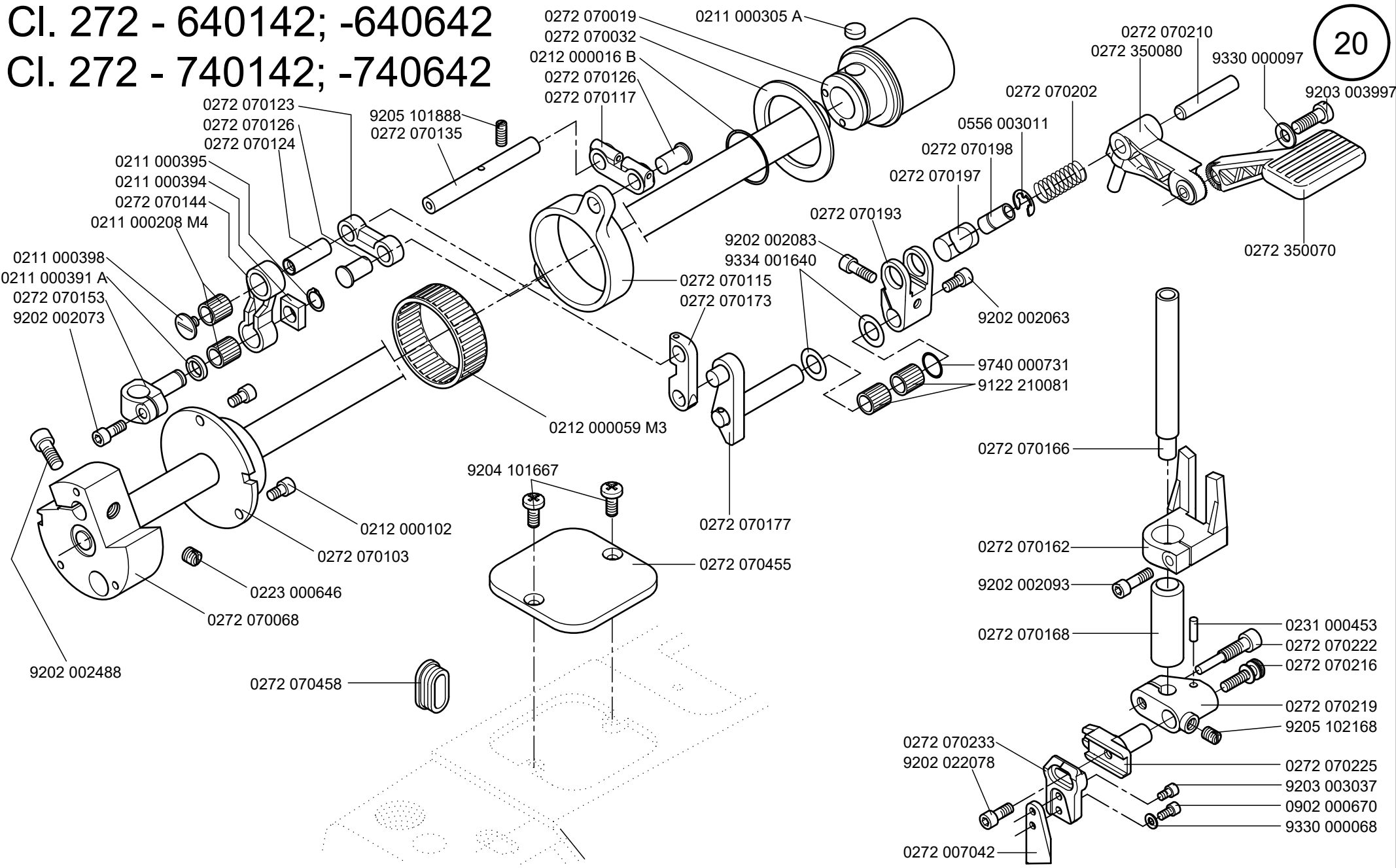

Scale 50%

CI. 271, 272, 273, 274

letzte Änderung/ last change 03.2009  
 Ausgabe/ Edition 06.2025



CI. 272 - 640142; -640642  
 CI. 272 - 740142; -740642

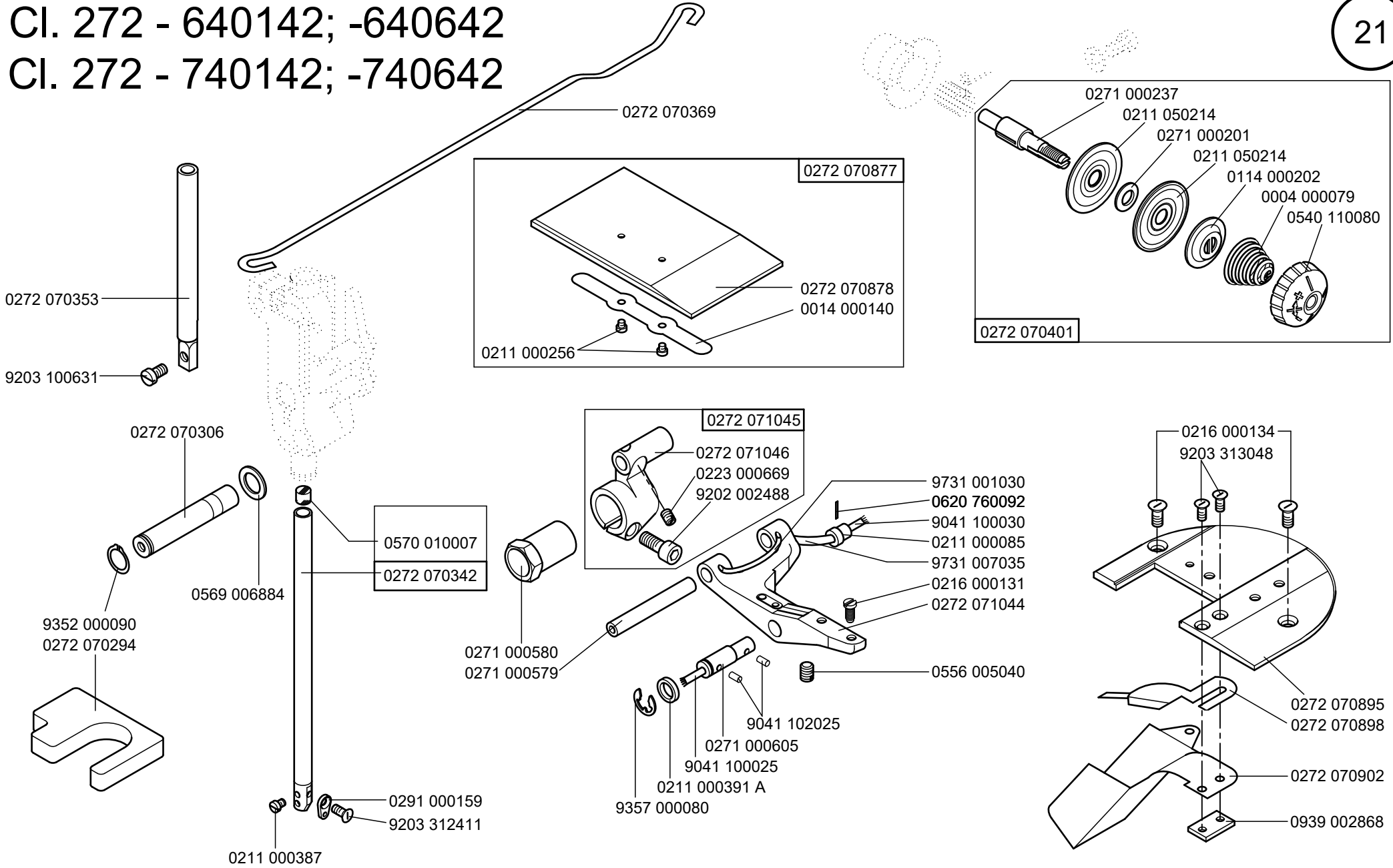

Scale 50%

CI. 271, 272, 273, 274

letzte Änderung/ last change 03.2009  
 Ausgabe/ Edition 06.2025

CI. 272 - 640142; -640642  
 CI. 272 - 740142; -740642

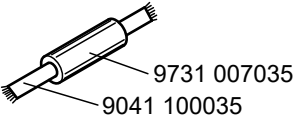
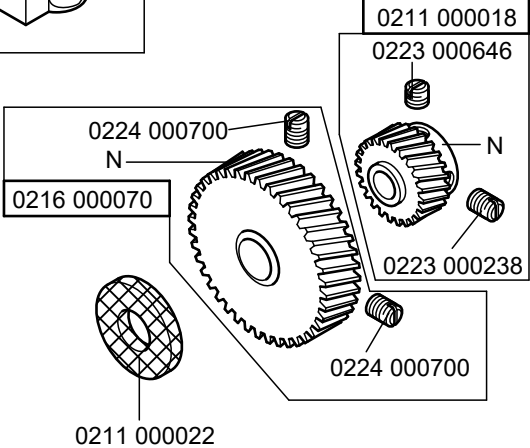
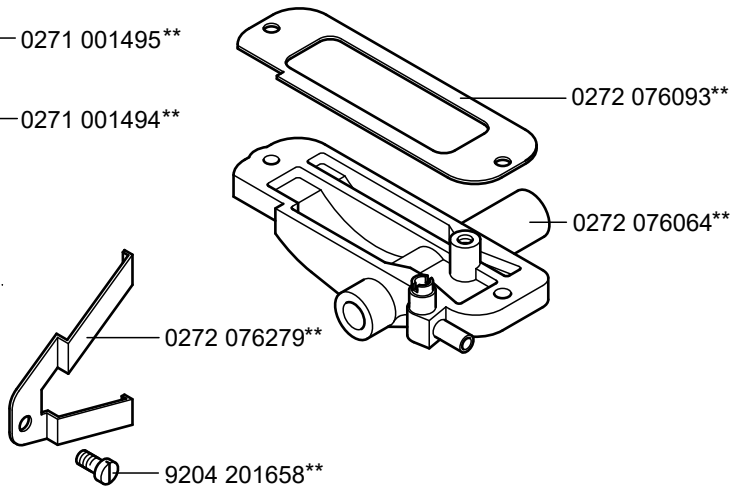
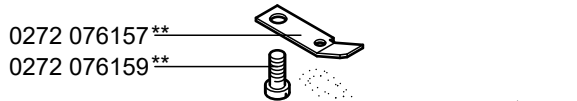
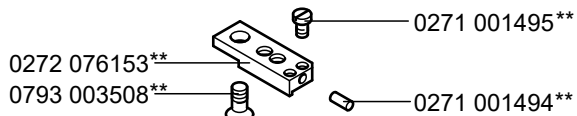
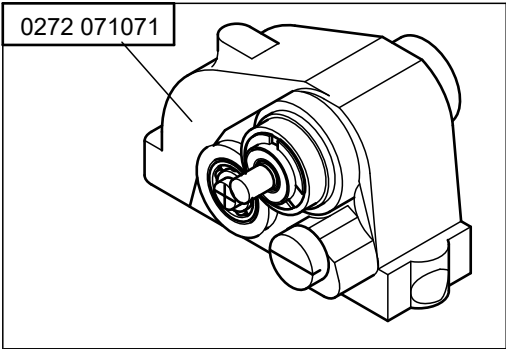
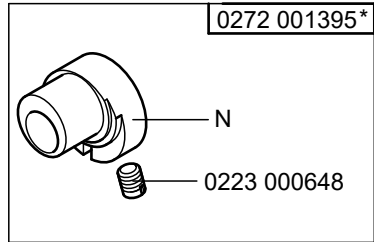

N- nicht als Einzelteil lieferbar  
 not available as separate part

\* nur für Kl. 272-140331, -140332, -140341, -140342, -640642, -740642 und 274-140342; only for Cl. 272-140331, -140332, -140341, -140342, -640642, -740642 und 274-140342

\*\* nur für Kl. 272-640642 und -740642; only for cl. 272-640642 und -740642

# CI. 272 - 740142; -740642

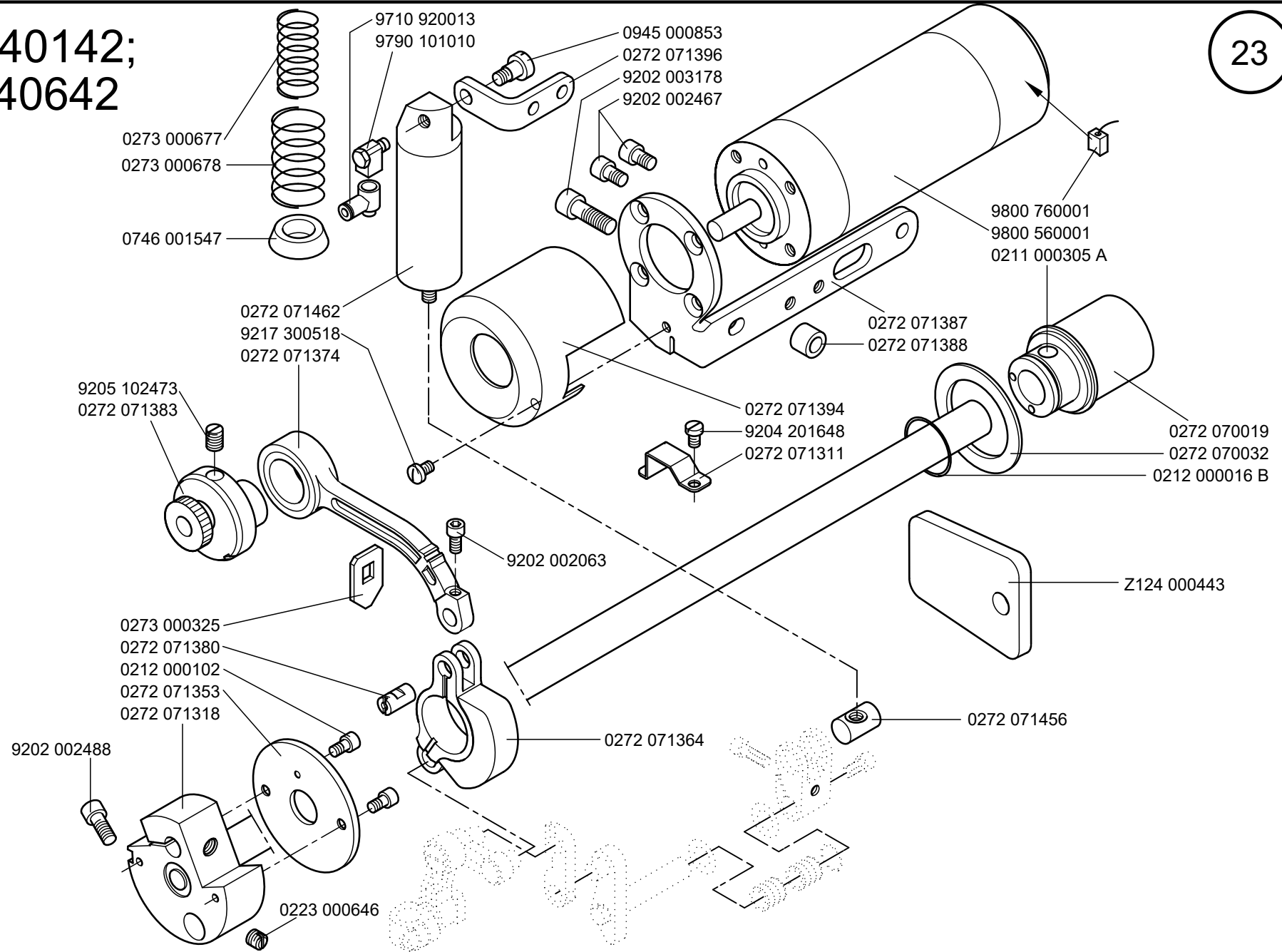

CI. 272 - 740142; -740642

9850 272003

9231 110037  
0798 123916

9850 272005

9830 400125

0798 221026

9805 300001

0993 087138

9815 114001

0993 087108

9870 272004

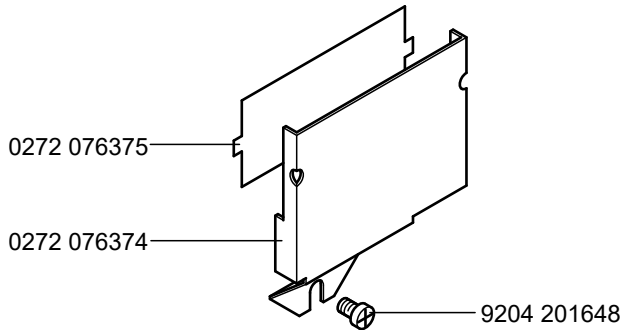
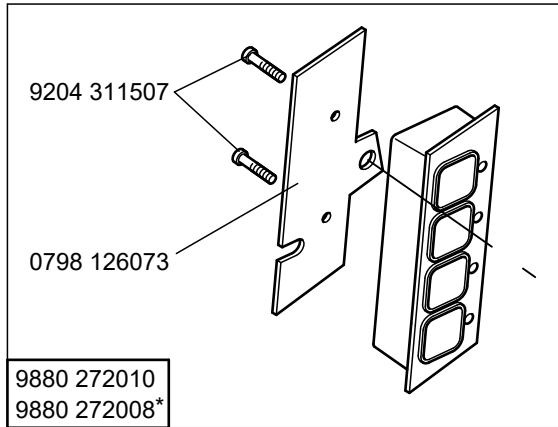
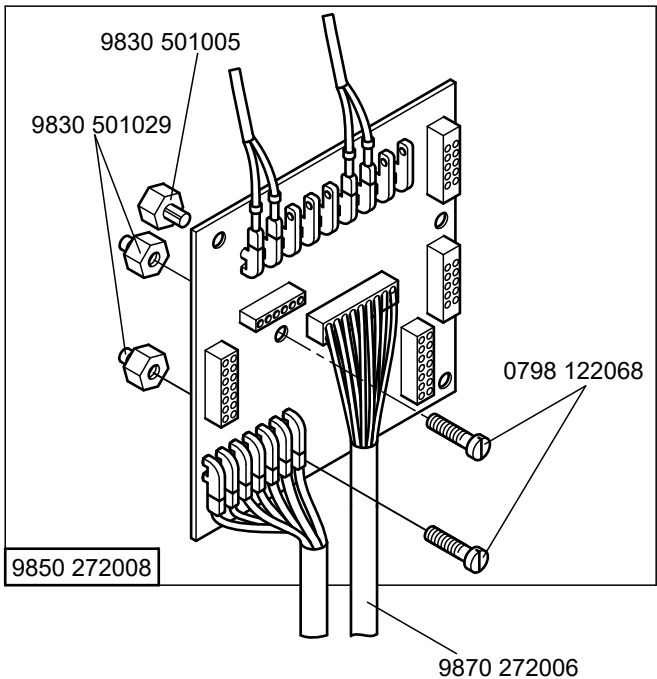

nur für Kl. 272-740642; only for Cl. 272-740642  
\* nur für Kl. 272-640642; only for Cl. 272-640642

Scale 50%

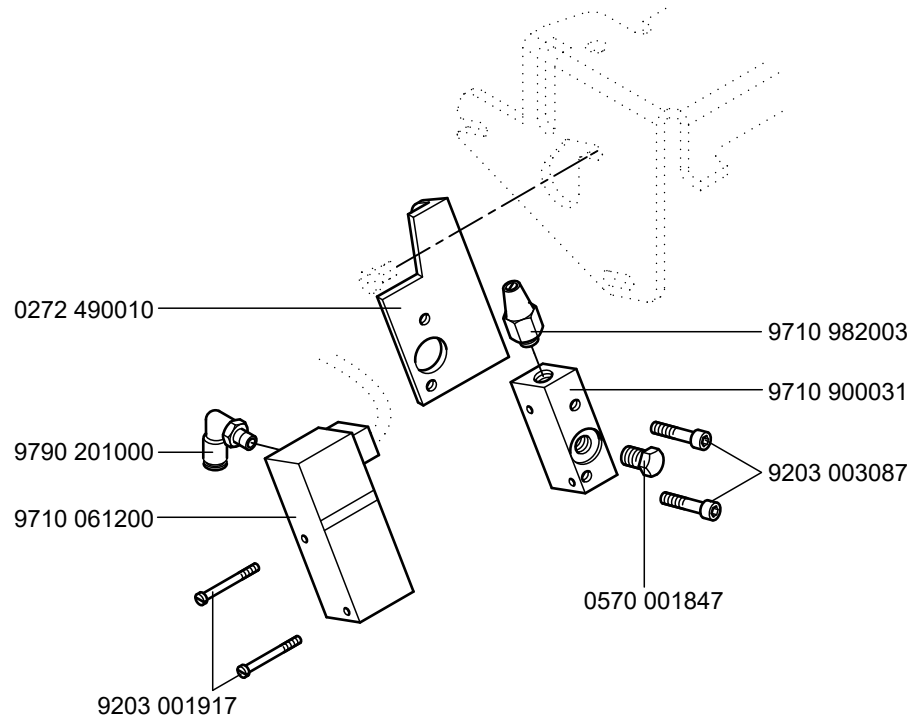

# Cl. 273, 274

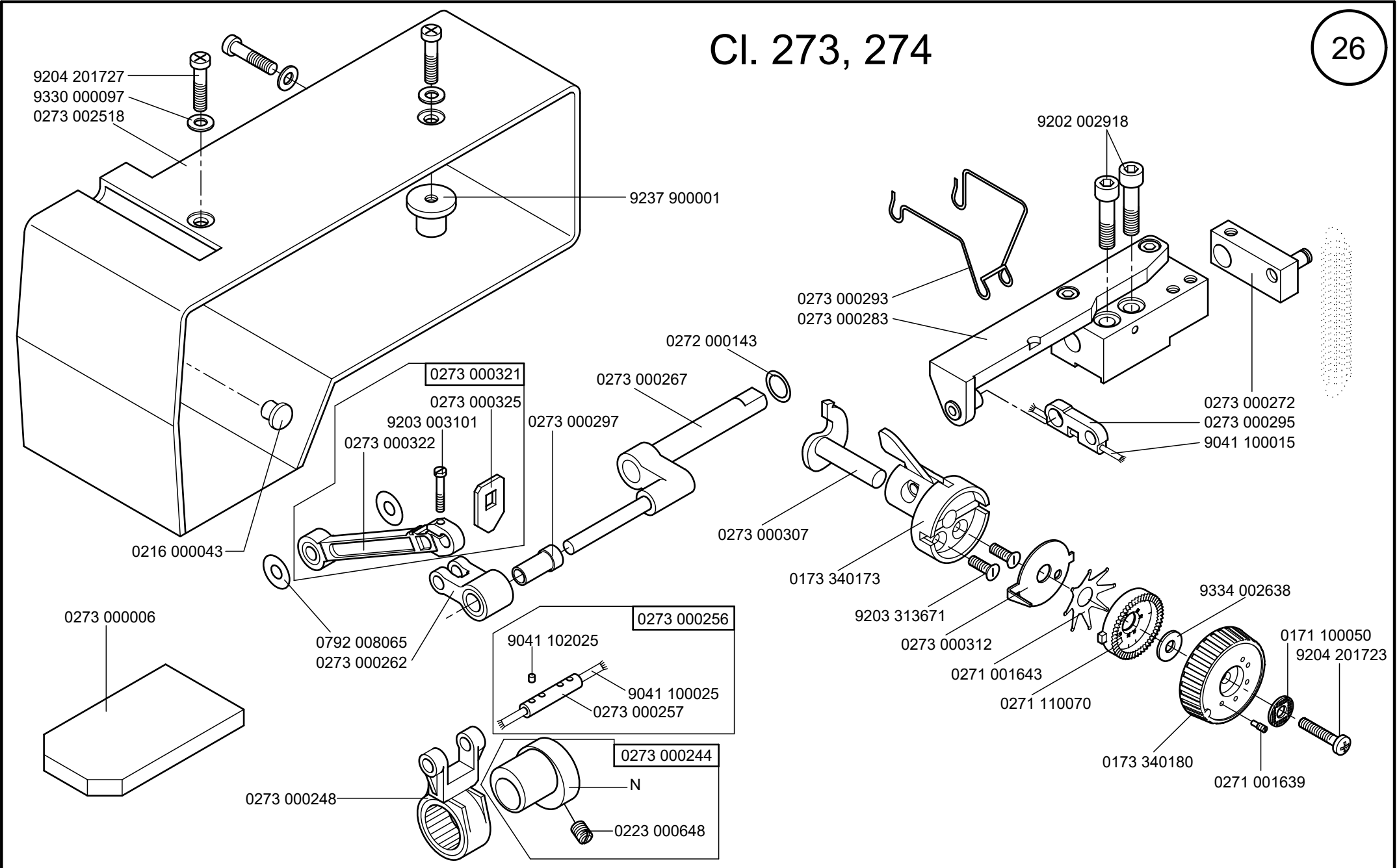

Scale 50%

# Cl. 271, 272, 273, 274

# CI. 273, 274

27

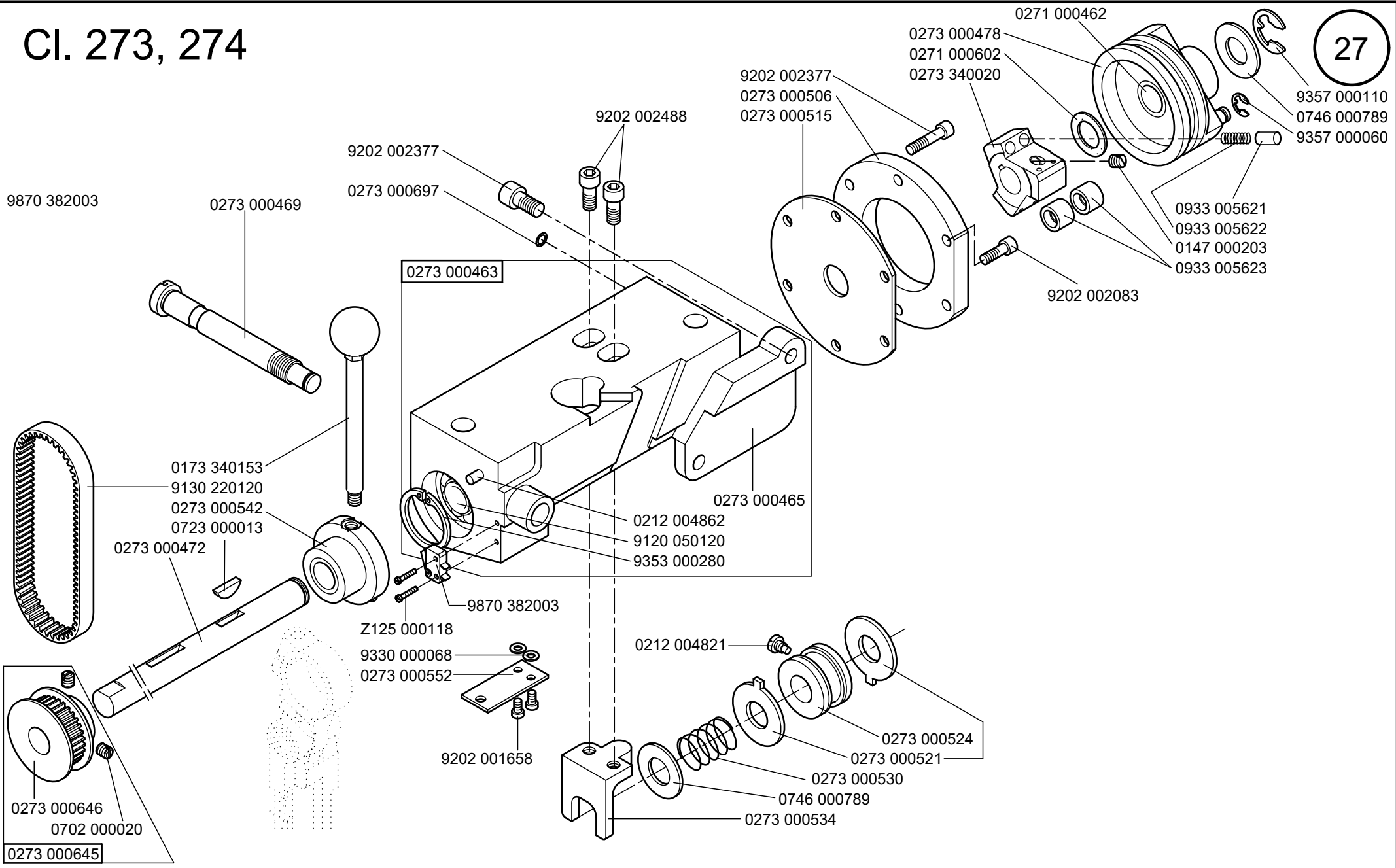

Scale 50%

# CI. 271, 272, 273, 274

letzte Änderung/ last change 11.2023  
Ausgabe/ Edition 06.2025

# CI. 273 , 274

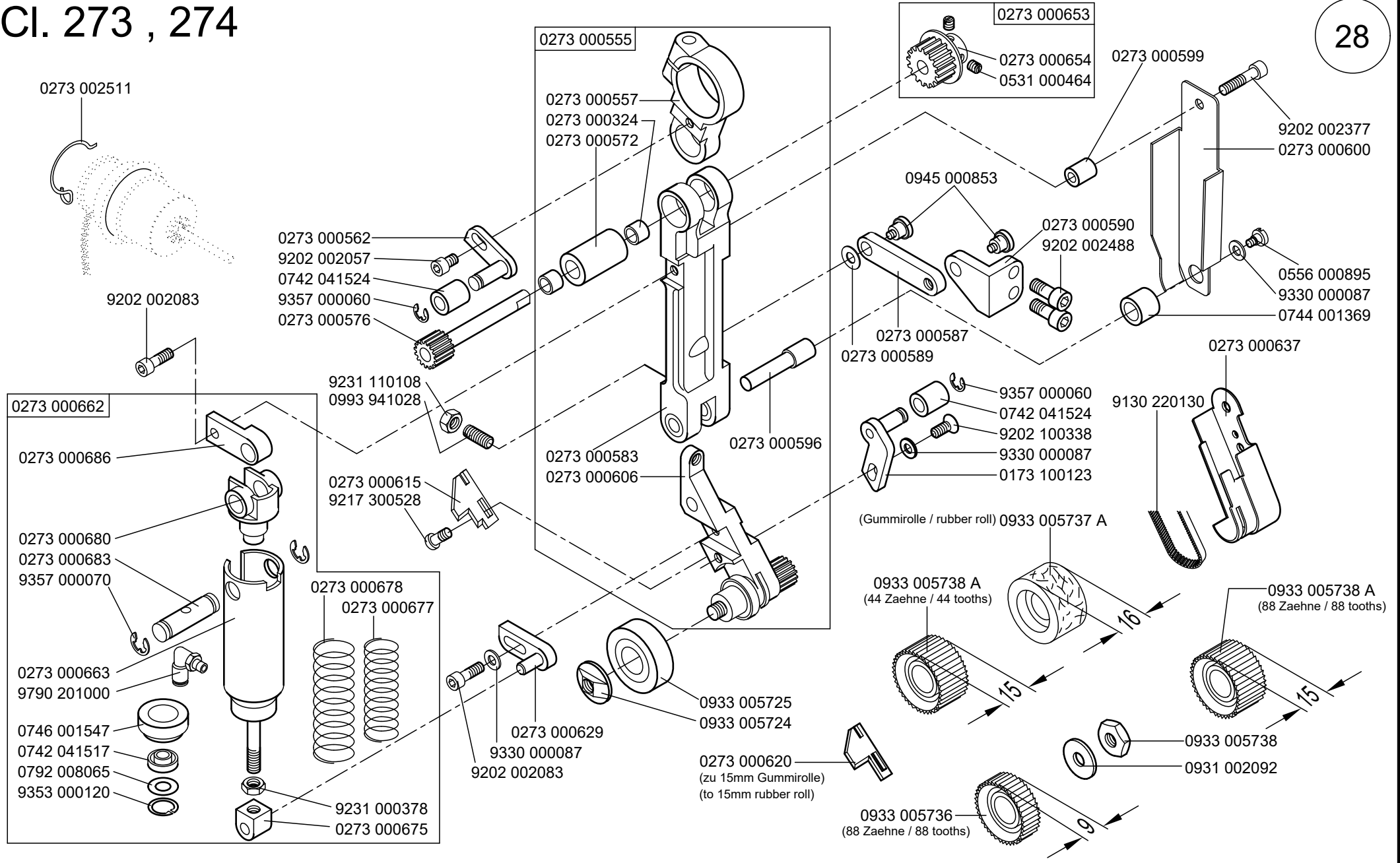



0273 001041

auf Wunsch  
on request

# CI. 273

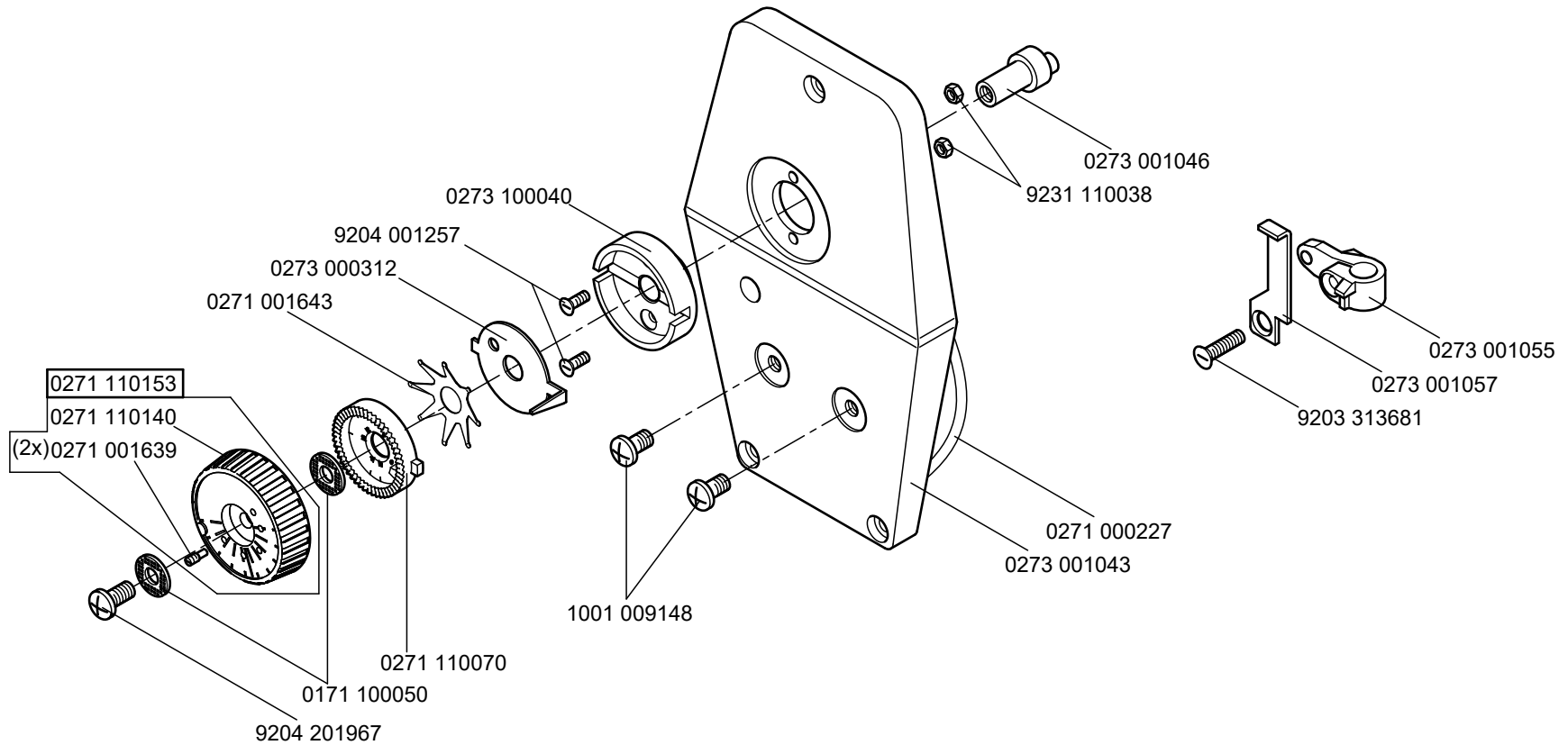

0274 001141

auf Wunsch  
on request

# CI. 271 -140042 CI. 274 -140342

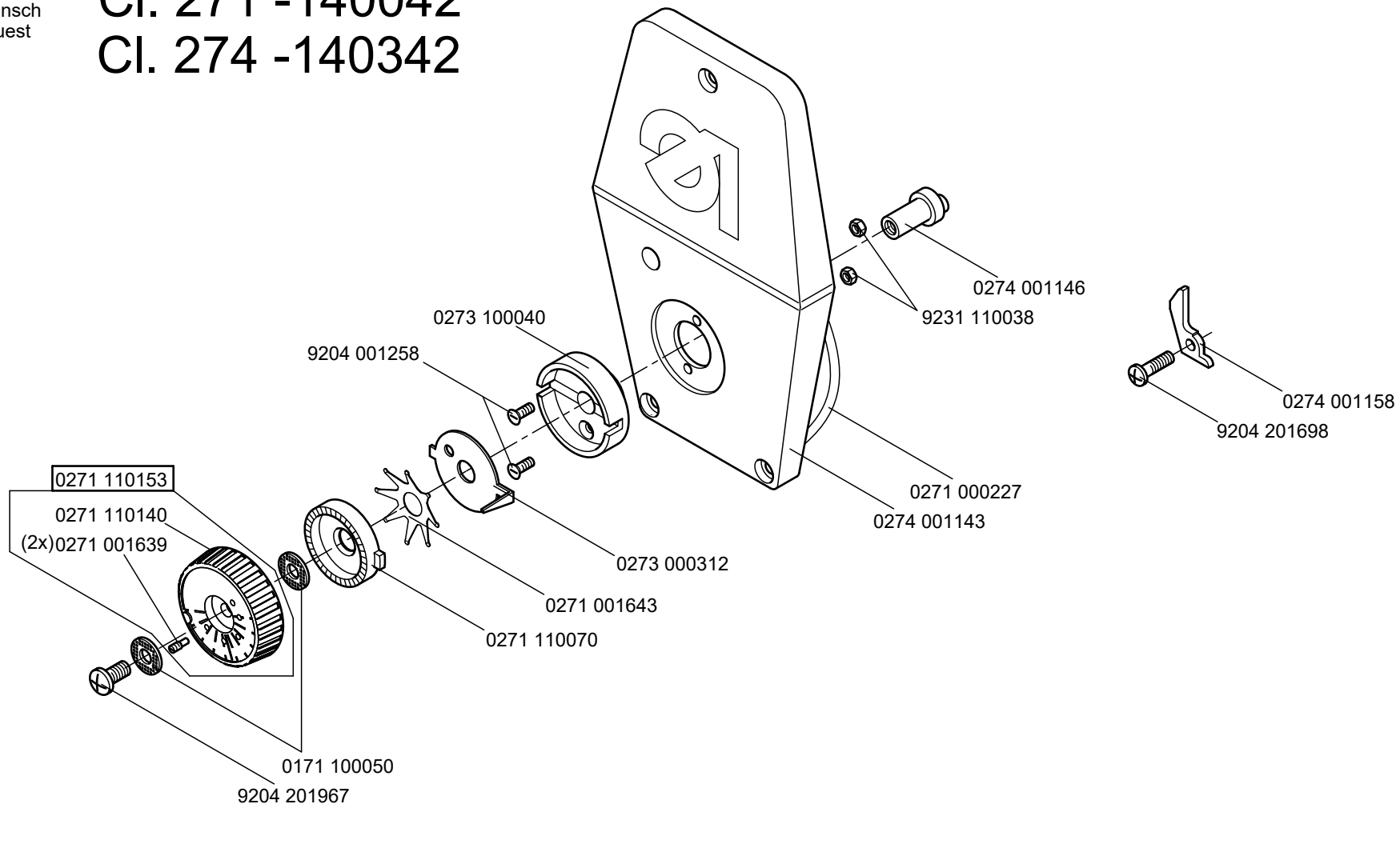

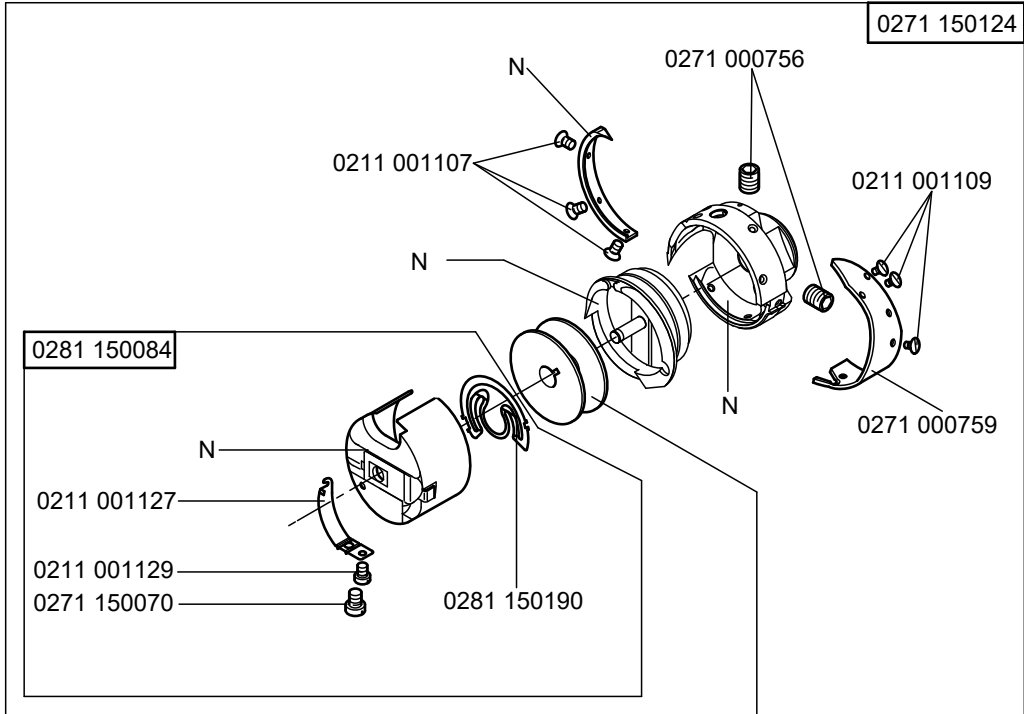

Cl. 271 - 140331; -140332; -140341; -140342  
 Cl. 272 - 140331; -140332; -140341; -140342; -640642; -74642  
 Cl. 273 - 140342  
 Cl. 274 - 140342

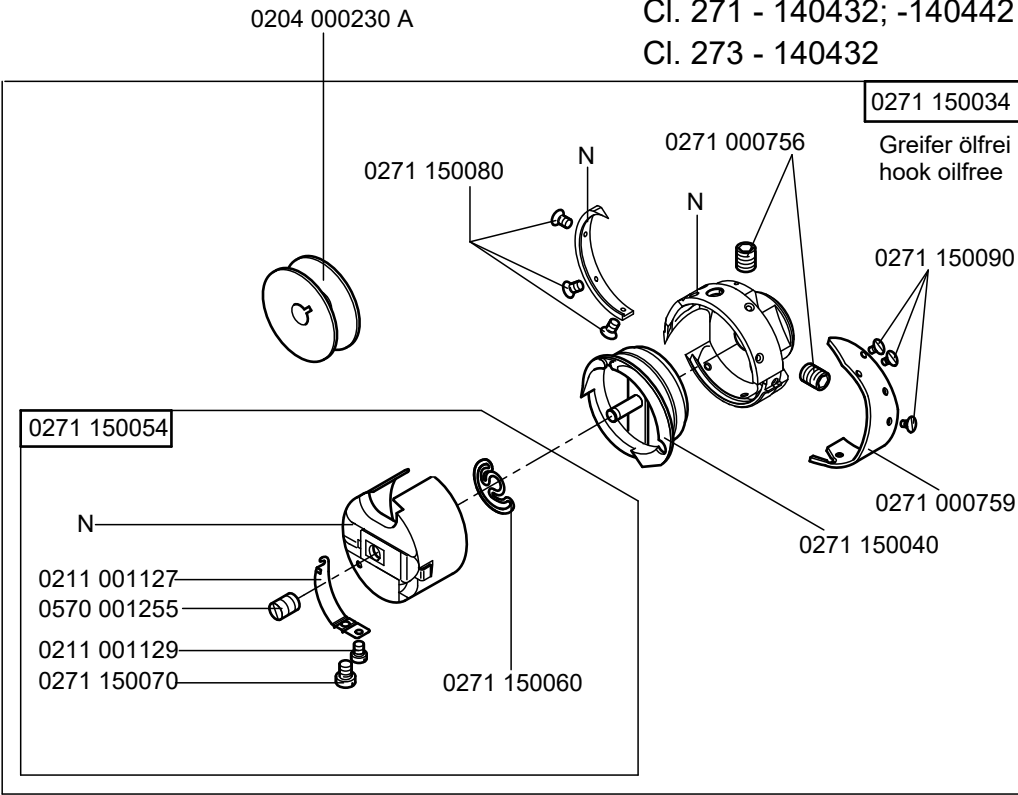

Cl. 271 - 140432; -140442  
 Cl. 273 - 140432

N- nicht als Einzelteil lieferbar  
 not available as separate part

# CI. 272-160362

0271 002121  
auf Wunsch  
on request

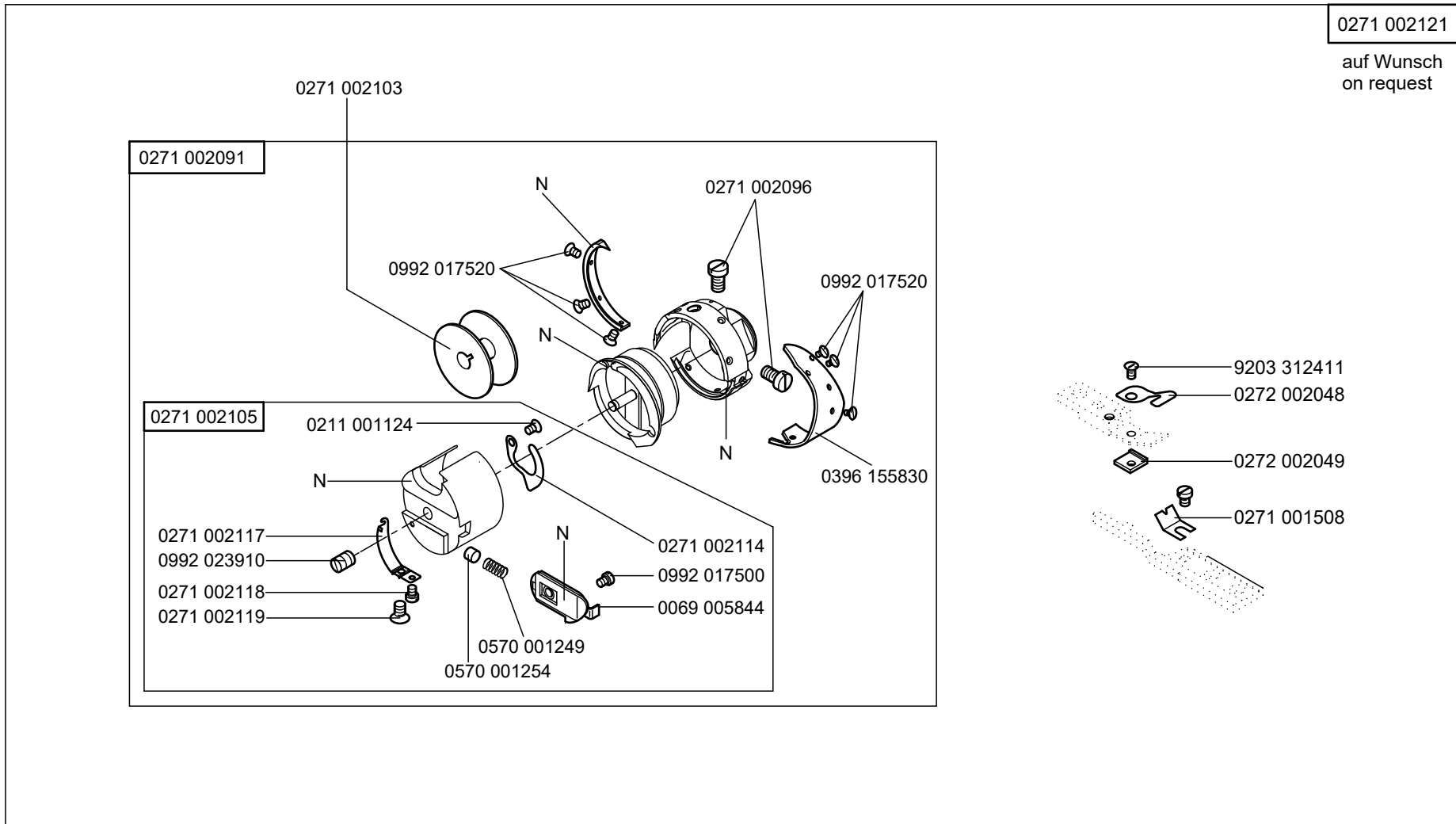

N- nicht als Einzelteil lieferbar  
not available as separate part

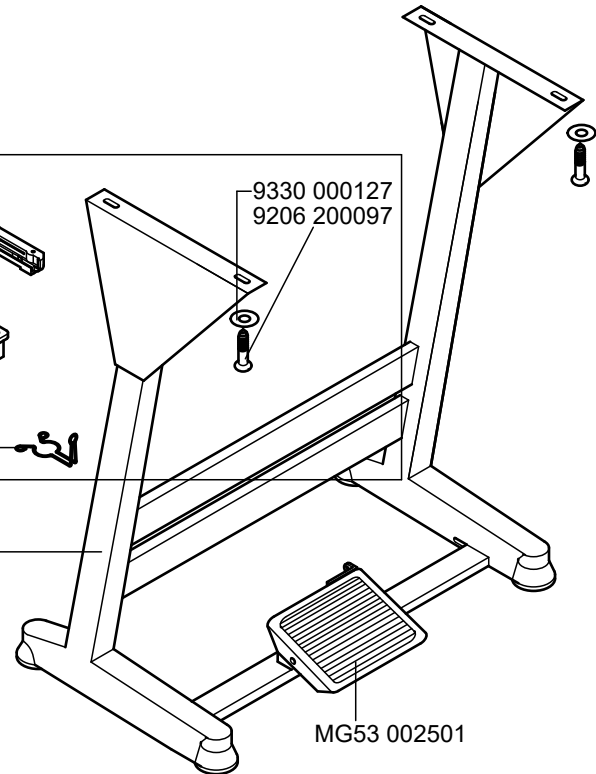
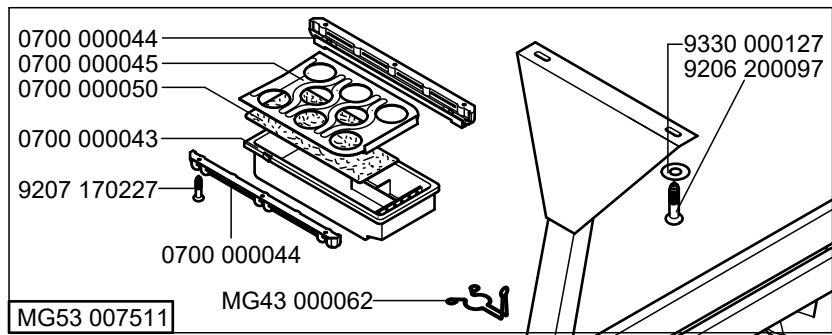
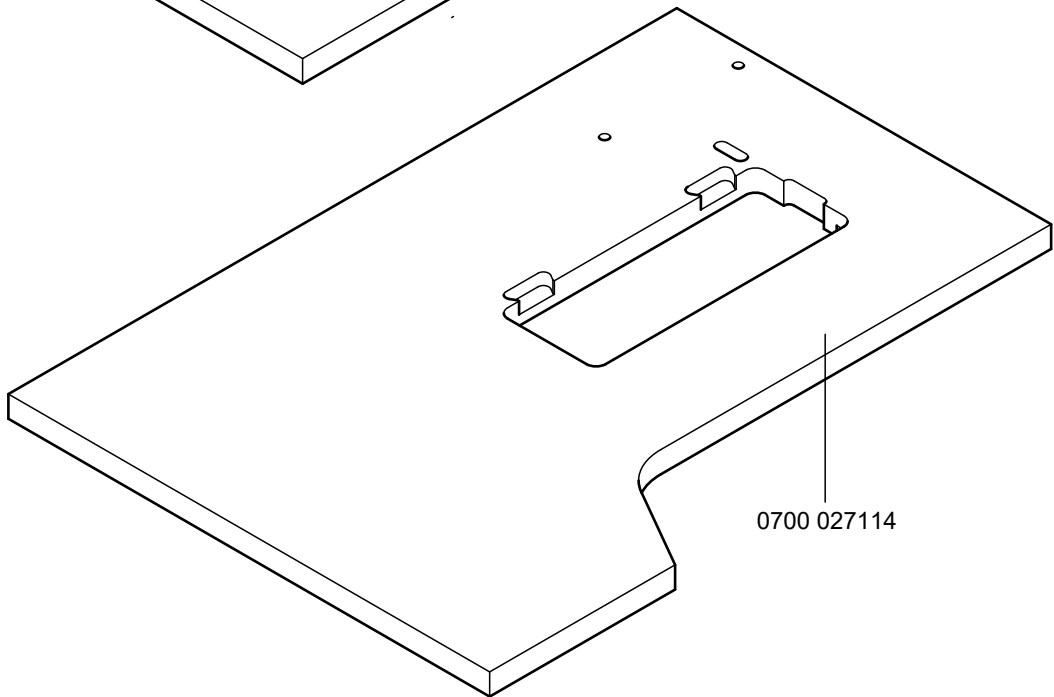
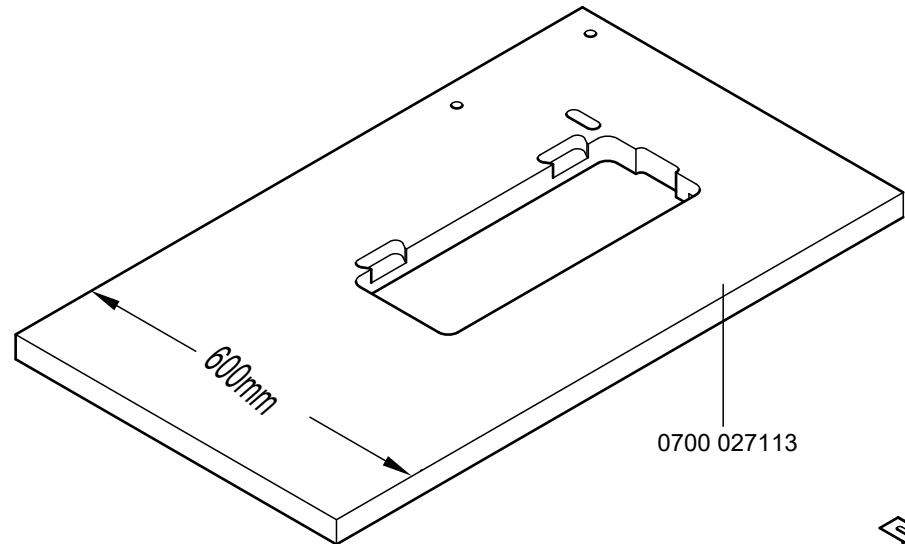
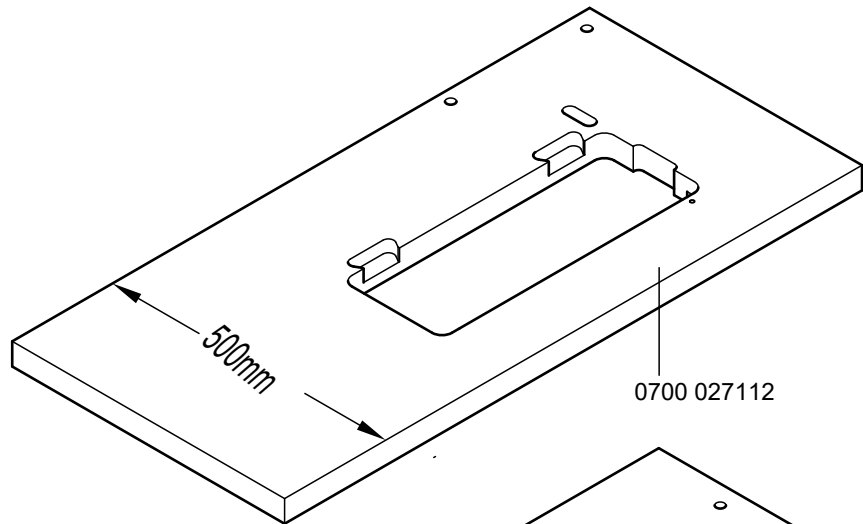

MG53 400015 = MG53 007511 + MG53 000501 + MG53 002501 + 0700 027112

MG53 400016 = MG53 007511 + MG53 000501 + MG53 002501 + 0700 027113

MG53 400017 = MG53 007511 + MG53 000501 + MG53 002501 + 0700 027114

Scale ~10%

Cl. 271, 272, 273, 274

letzte Änderung/ last change  
Ausgabe/ Edition

03.2009  
06.2025

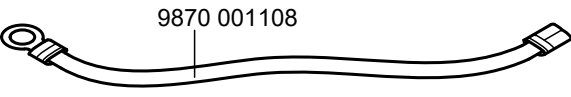
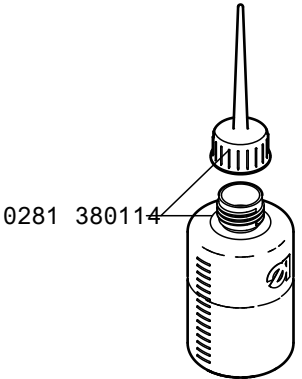
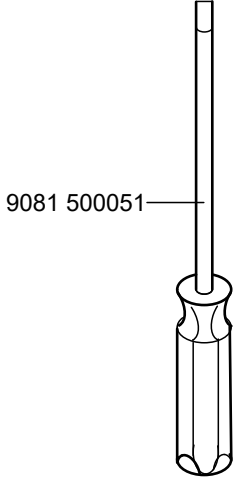
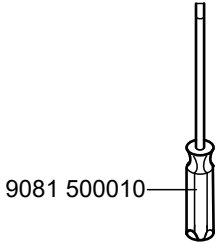
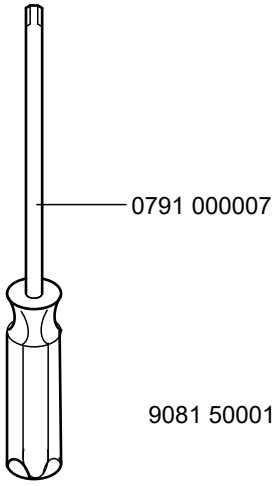
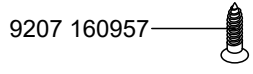
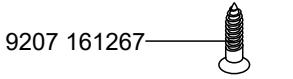
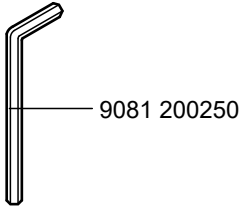
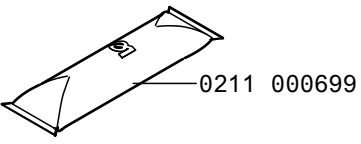
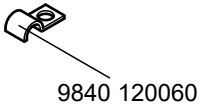
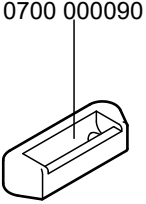
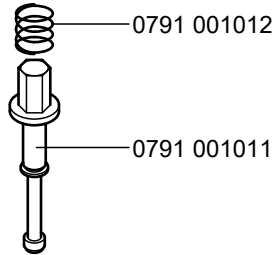
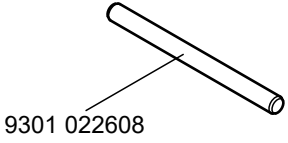
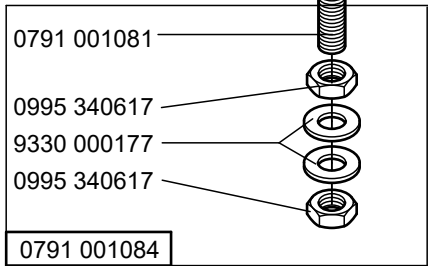
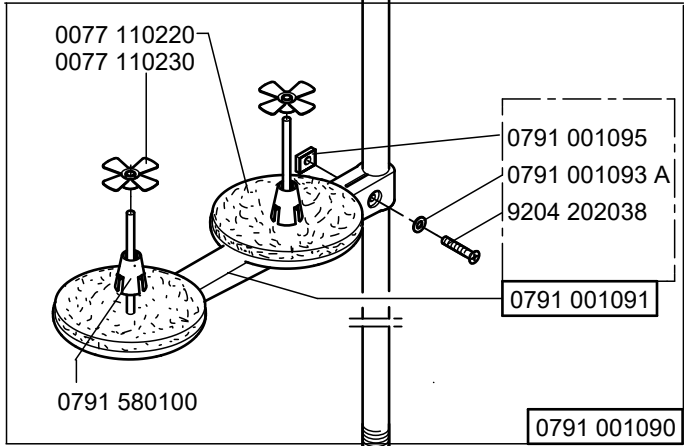
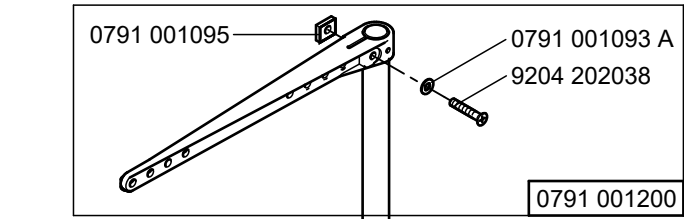

- 0791 272505
- 0791 272506
- 0791 271504
- 0791 273502

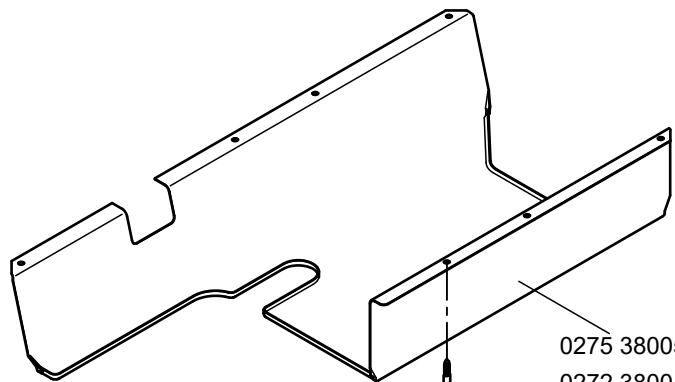

0275 380050 \*  
 0272 380010 \*\*  
 \*\*\*\*\*  
 9207 170227

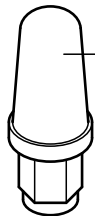

0791 001053 \*  
 \*\*  
 \*\*\*

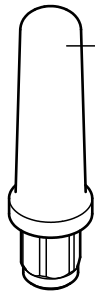

0052 000328 \*\*\*\*\*



0204 000230 A \*  
 \*\*\*\*\*  
 0271 002103 \*\*

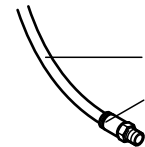

9731 005004 \*\*\*  
 9790 200001 \*\*\*



0990 490128 \*\*  
 \*\*\*  
 \*\*\*\*\*

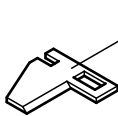

0273 000620 \*\*\*\*\*

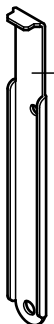

0791 000009 \*\*\*\*\*

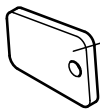

Z124 000443



0744 001155 \*\*\*\*\*

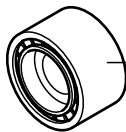

0933 005737 A \*\*\*\*\*

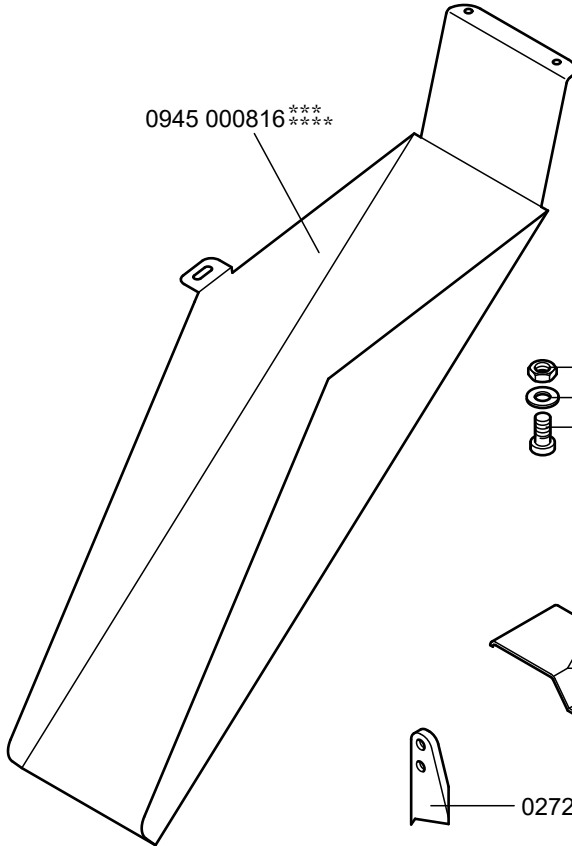

0945 000816 \*\*\*  
 \*\*\*

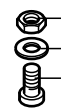

9231 000051 \*\*\*  
 9330 000088 \*\*\*  
 0219 000353 \*\*\*

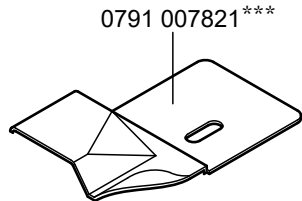

0791 007821 \*\*\*



0272 007045 \*\*\*

0791 271504	*
0791 272505	**
0791 272506	***
0791 273502	*****

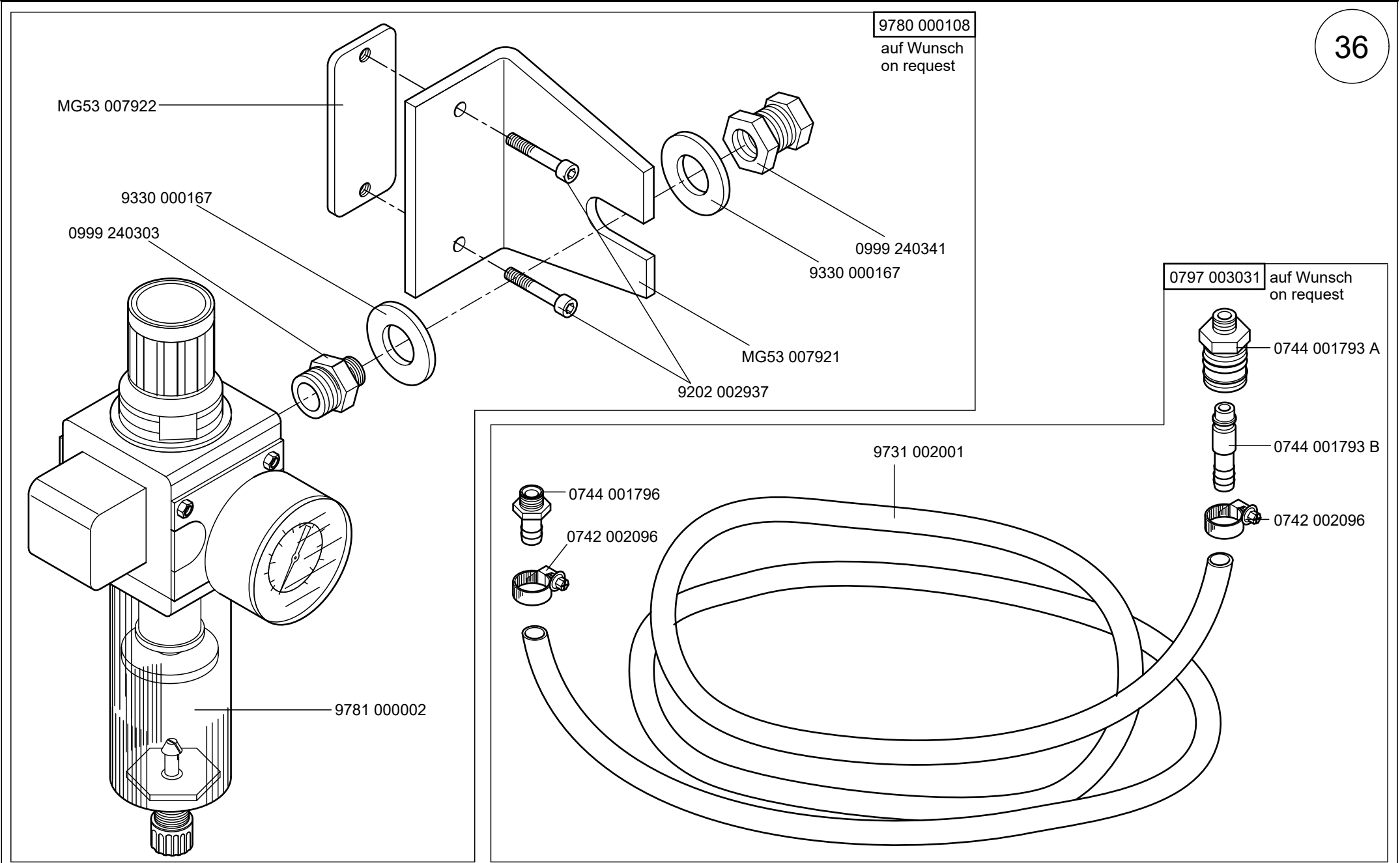



bis 12.2015 - until 12.2015

\*\*\* bis 05.2007 - until 05.2007 (HP20)

\*\*\*\* ab 06.2007 - from 06.2007 (HI BF 20N)

9822 510000	***
9822 510002	****

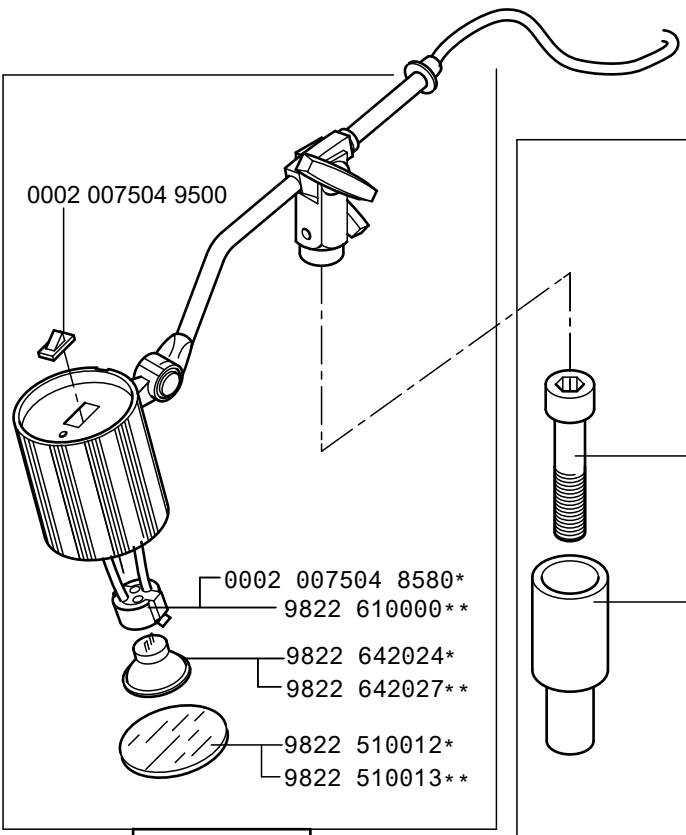

9822 510001	*
9822 510003	**

\* bis 05.2007 - until 05.2007

\*\* ab 06.2007 - from 06.2007

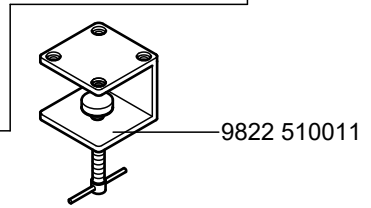
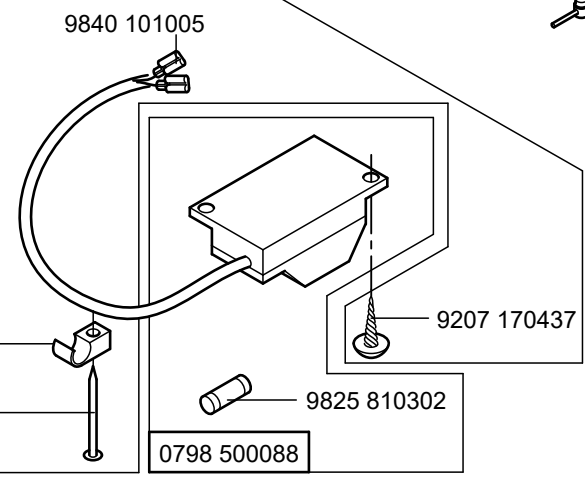
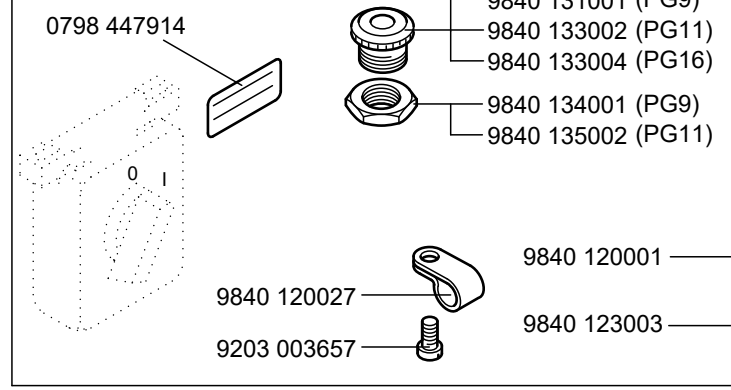
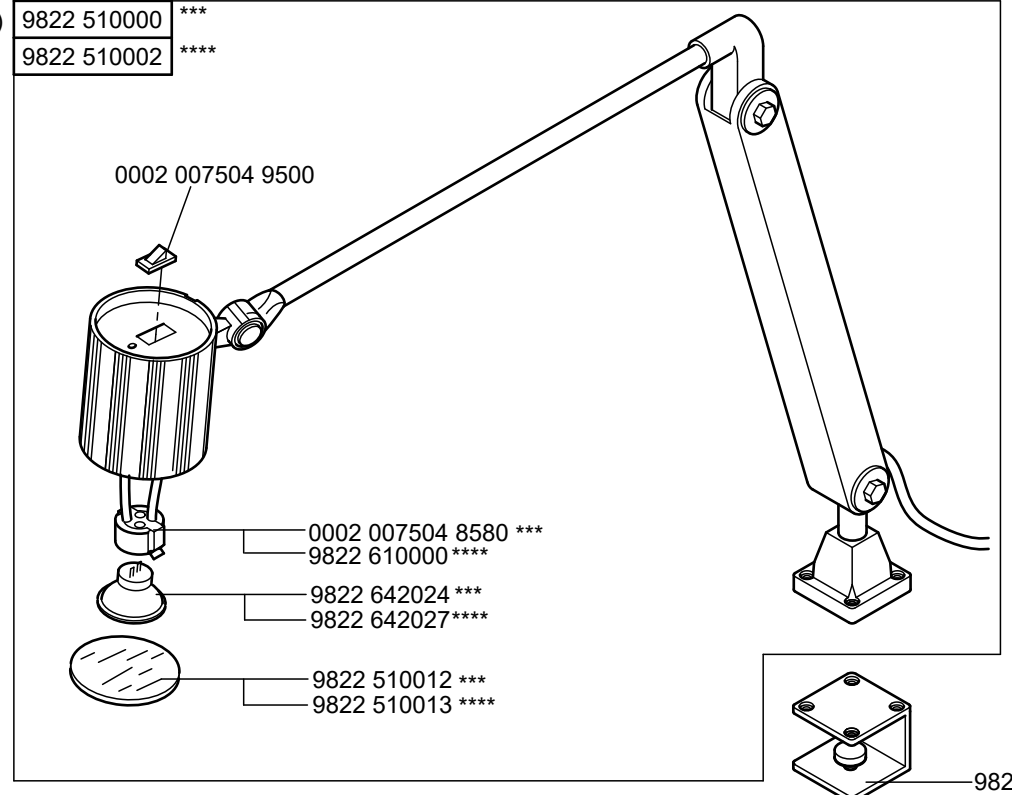
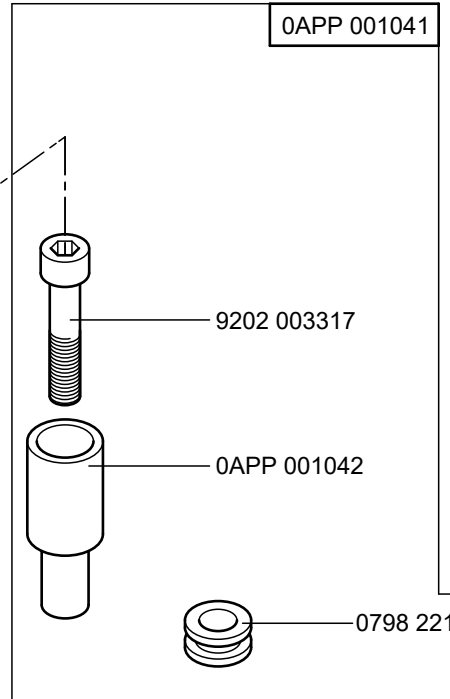

Scale 50%

Cl. 271, 272, 273, 274

letzte Änderung/ last change 11.2016  
Ausgabe/ Edition 06.2025

ab 01.01.2016 - from 01.01.2016

37.1

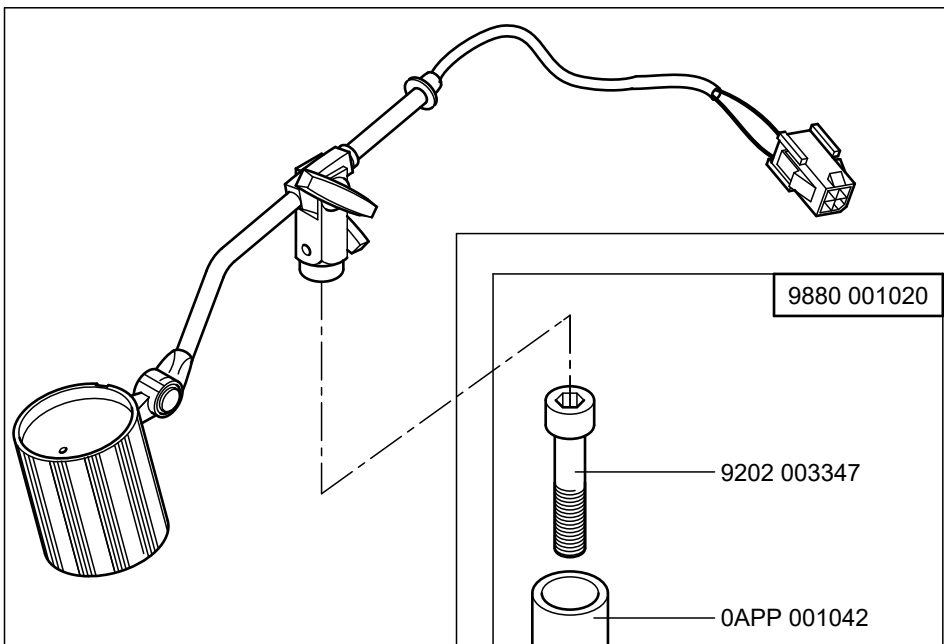

9822 560011

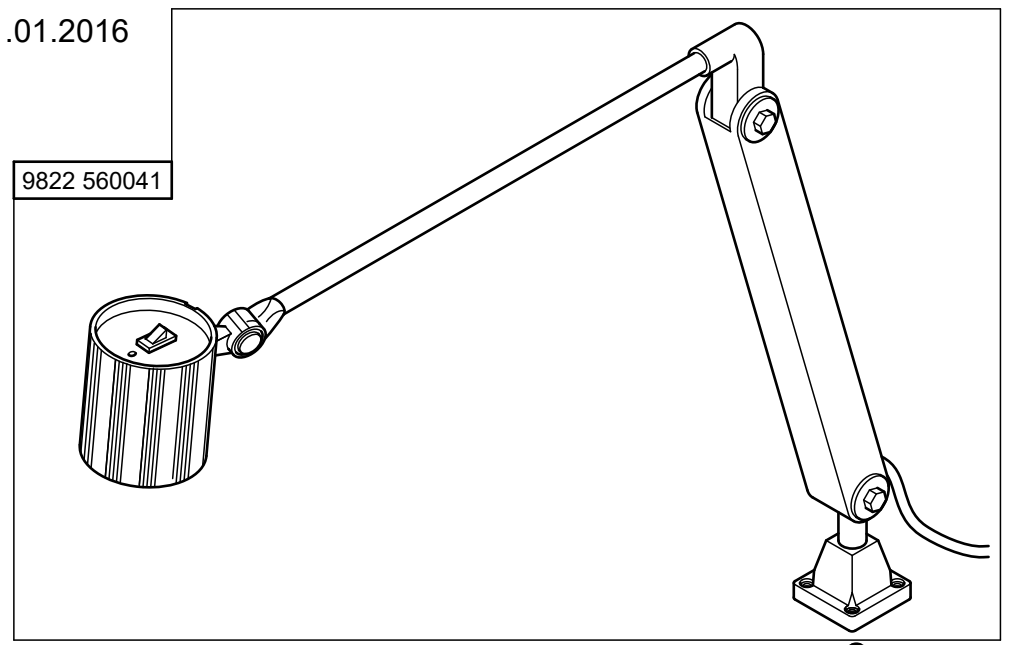

9822 560041

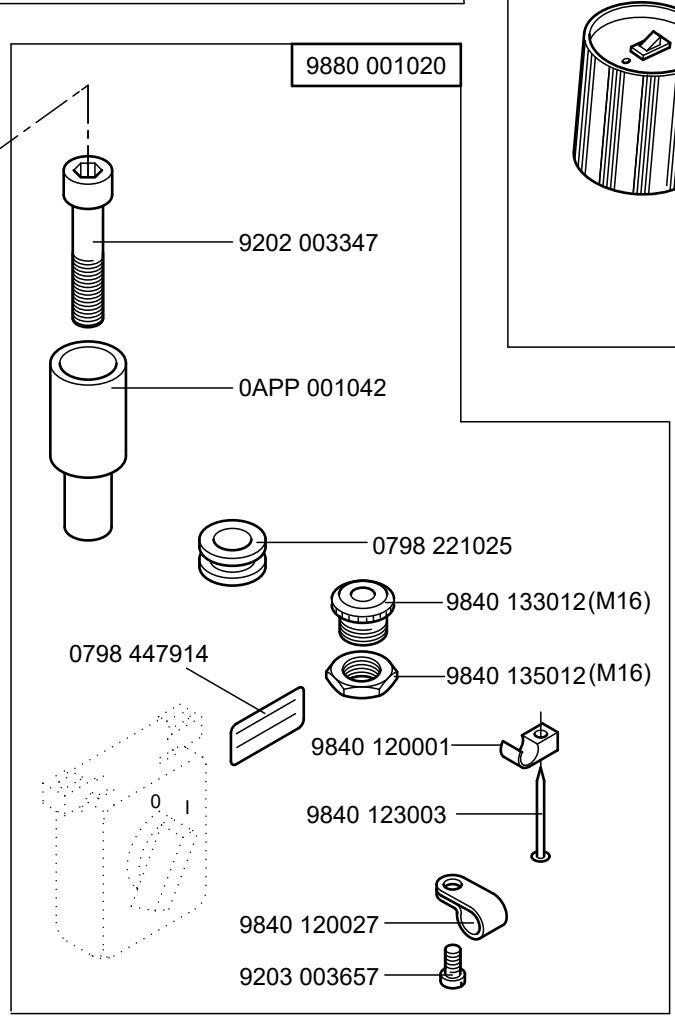

9880 001020

9202 003347

0APP 001042

0798 221025

9840 133012(M16)

9840 135012(M16)

0798 447914

9840 120001

9840 123003

9840 120027

9203 003657

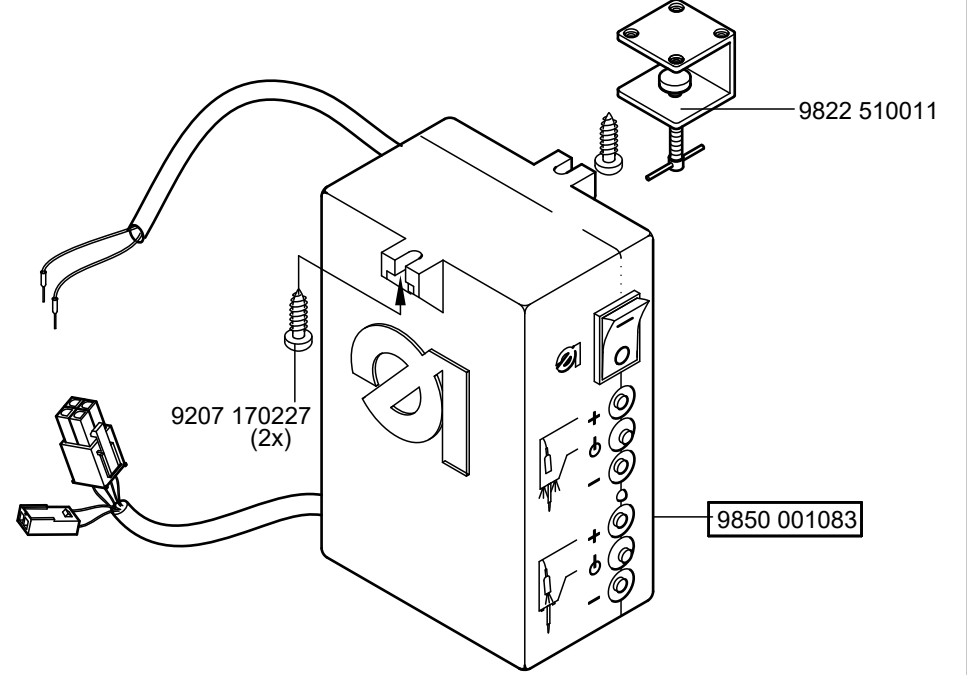

9822 510011

9207 170227 (2x)

9850 001083

Scale 50%

Cl. 271, 272, 273, 274

letzte Änderung/ last change 11.2016  
Ausgabe/ Edition 06.2025

0271 590044

auf Wunsch  
on request

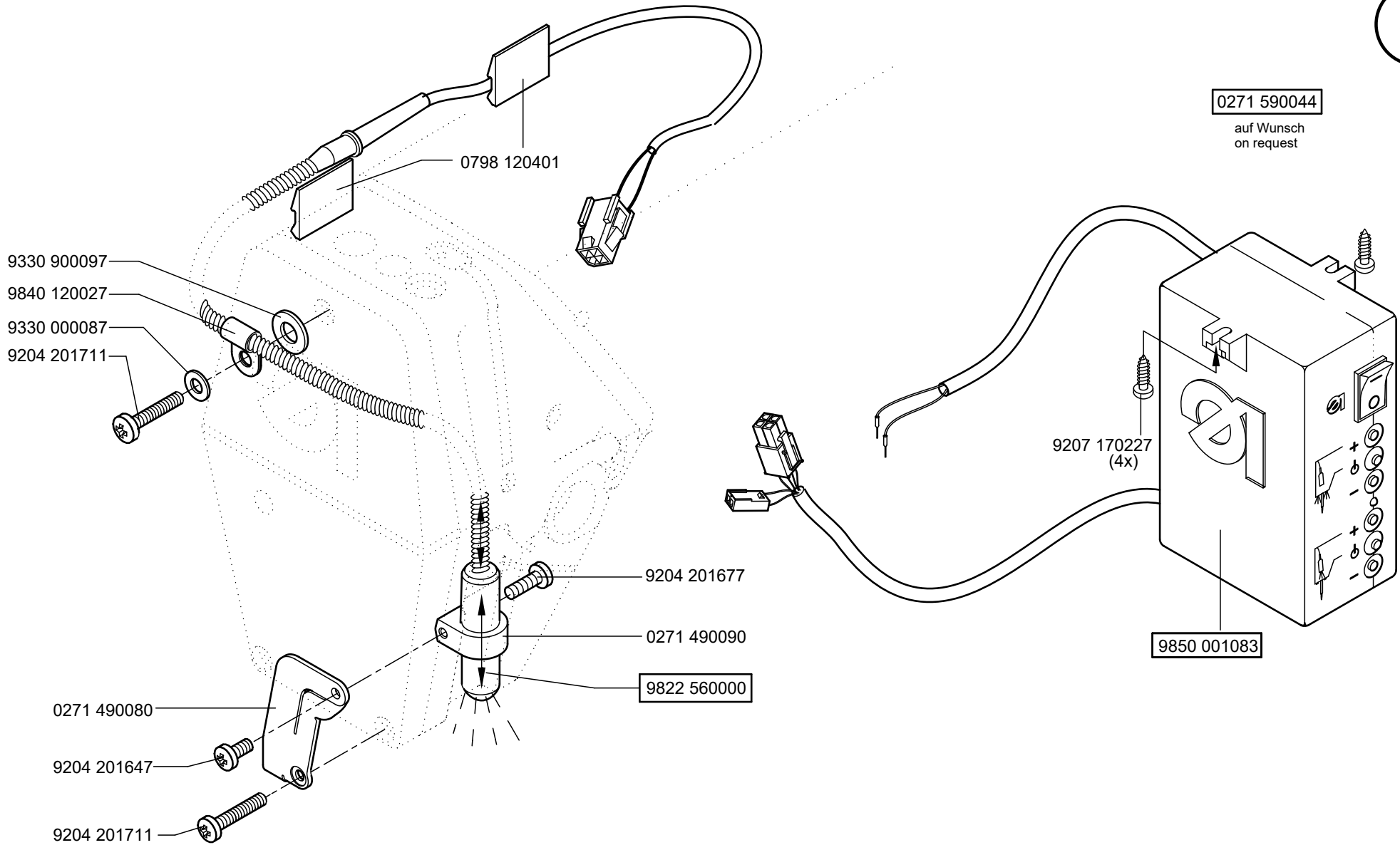

CI. 271-140342;  
-640642

39

0216 000288

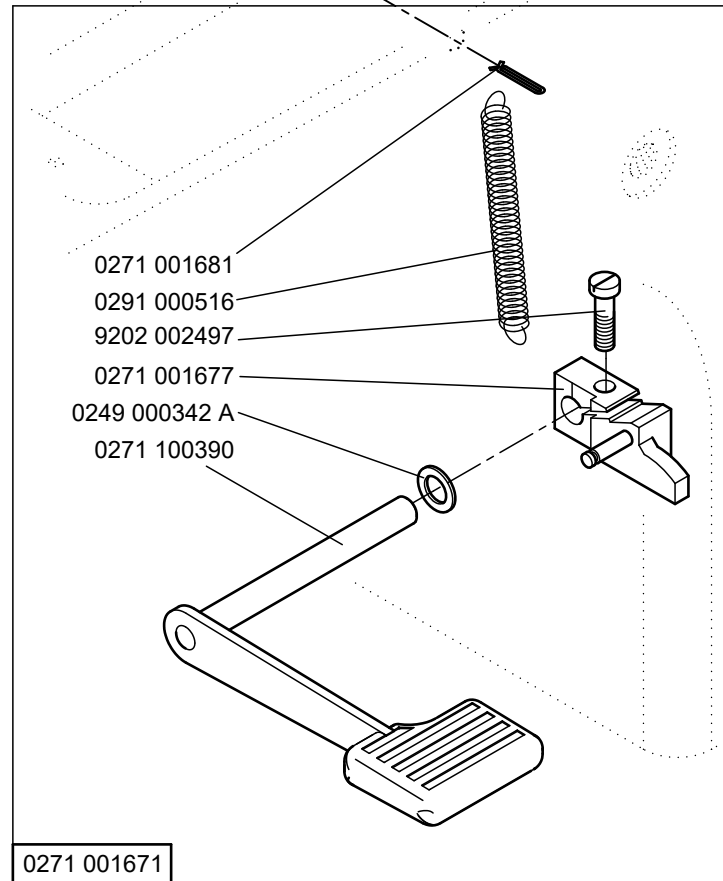

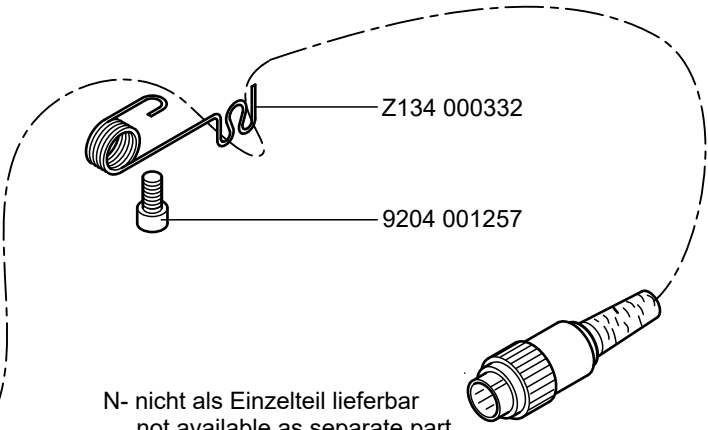
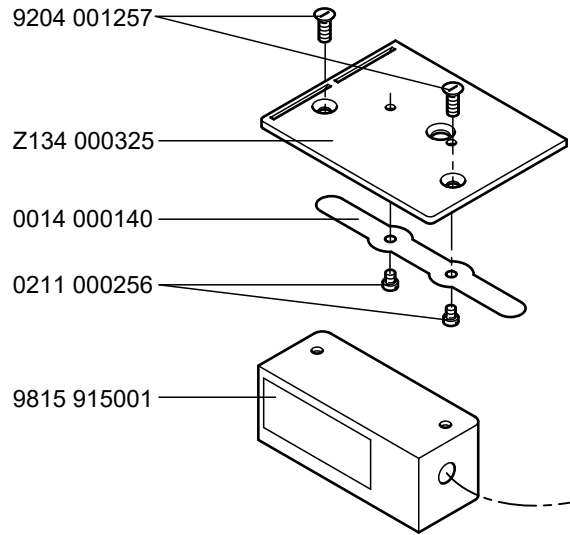

N- nicht als Einzelteil lieferbar  
not available as separate part

0271 002003

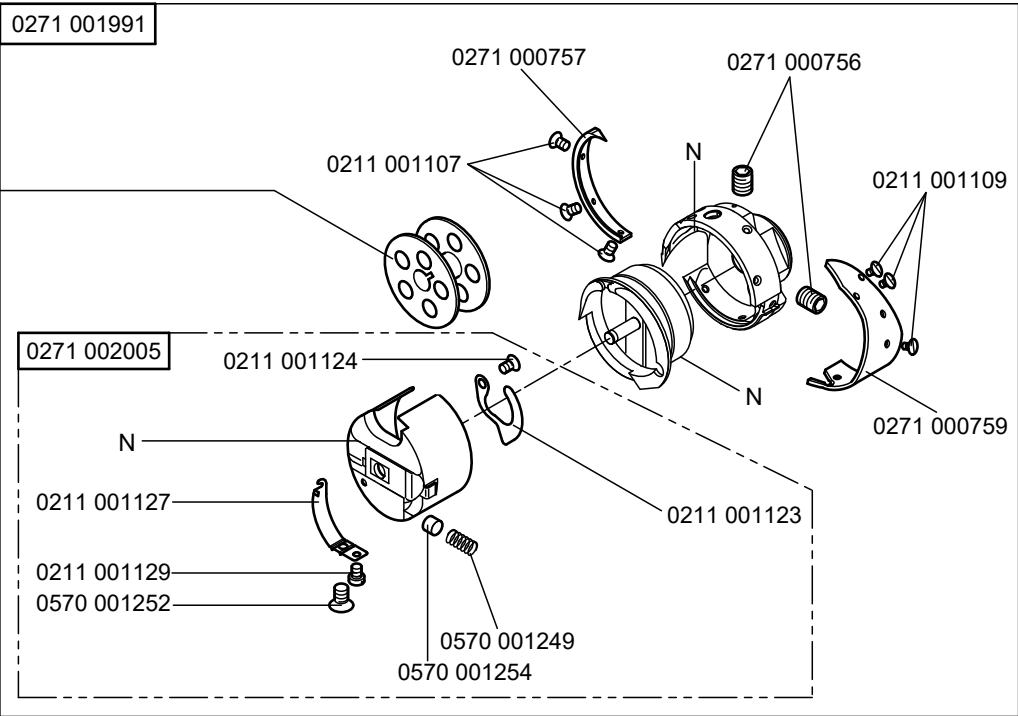

0271 590034 auf Wunsch  
on request

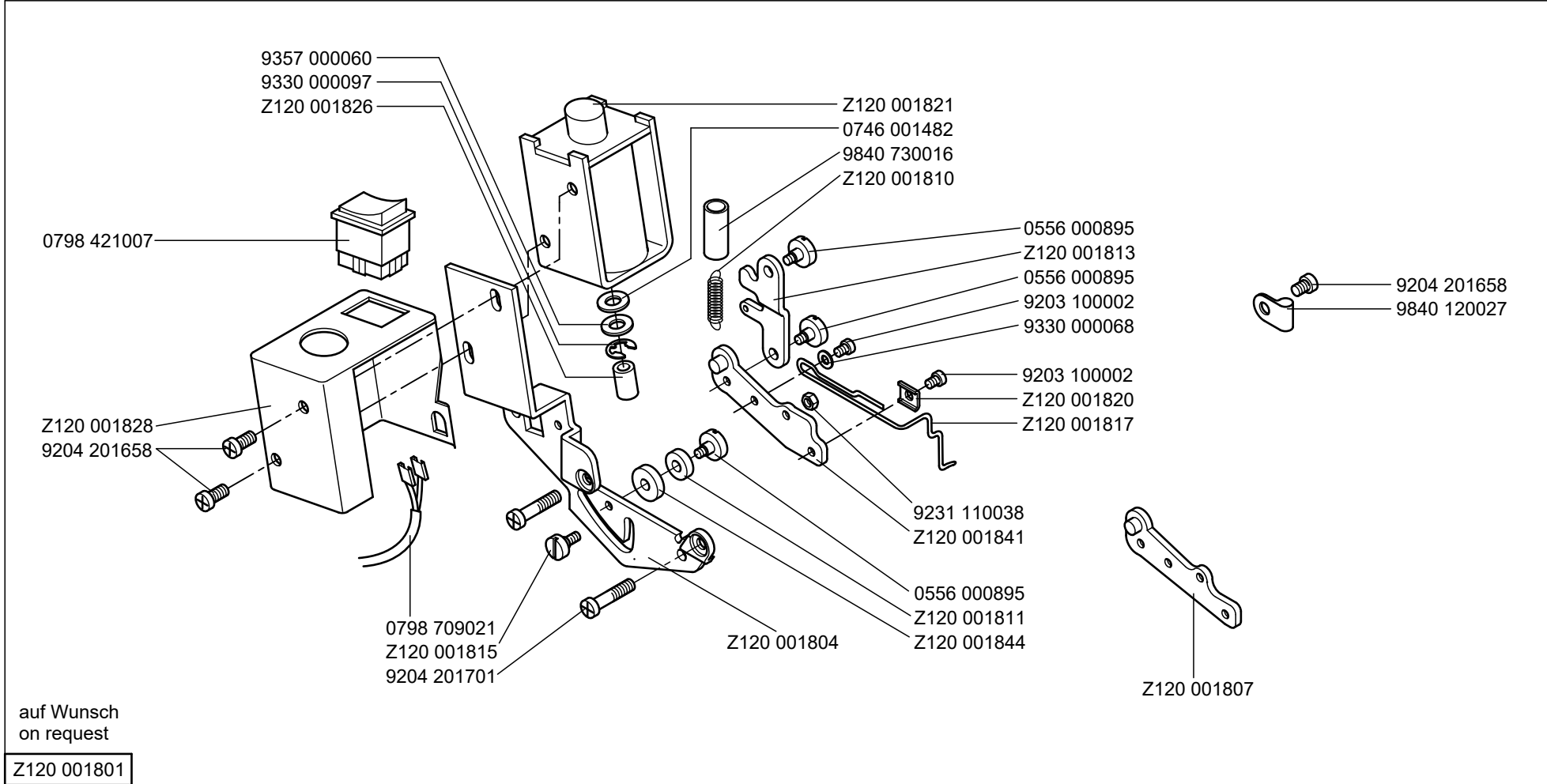

0271 590024

auf Wunsch  
on request

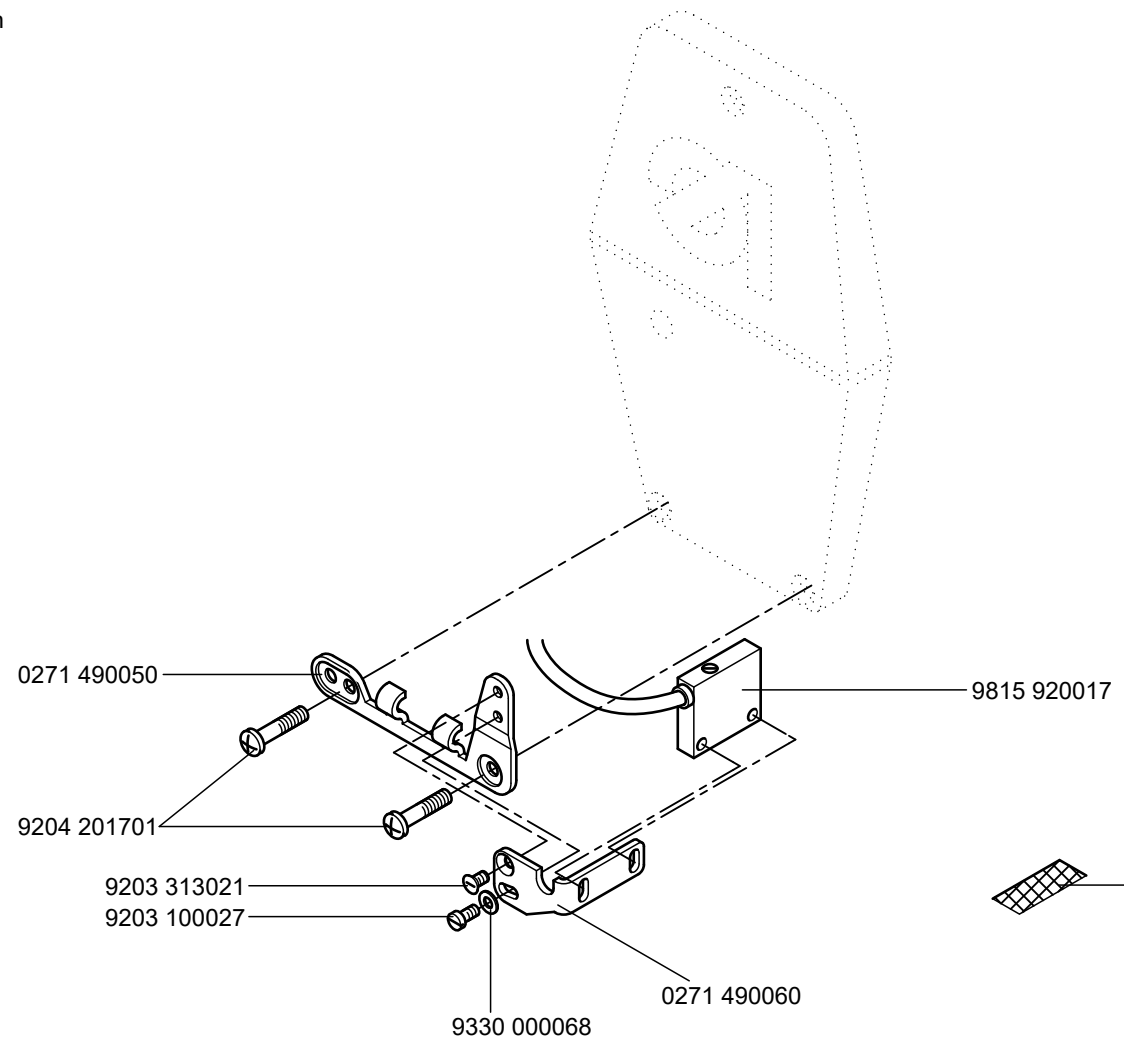

0271 000894

auf Wunsch  
on request

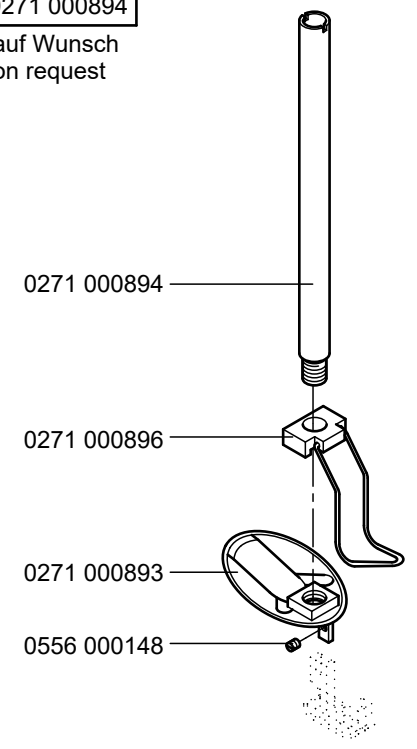

Z120 001851

Cl. 273, 274

43

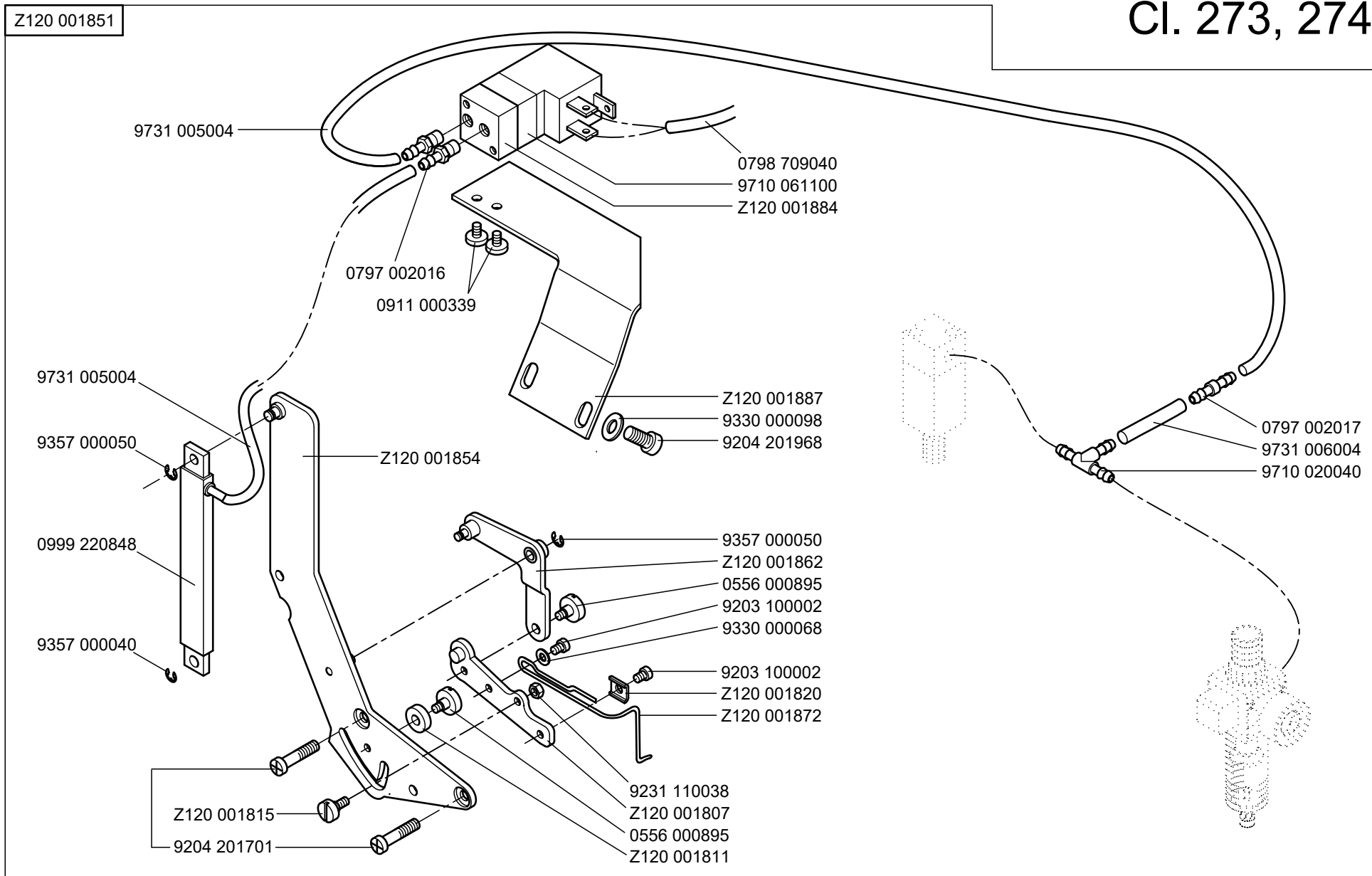

Scale 50%

Cl. 271, 272, 273, 274

letzte Änderung/ last change 03.2009  
Ausgabe/ Edition 06.2025



Z124 000501

auf Wunsch  
on request

CI. 272-640642

44

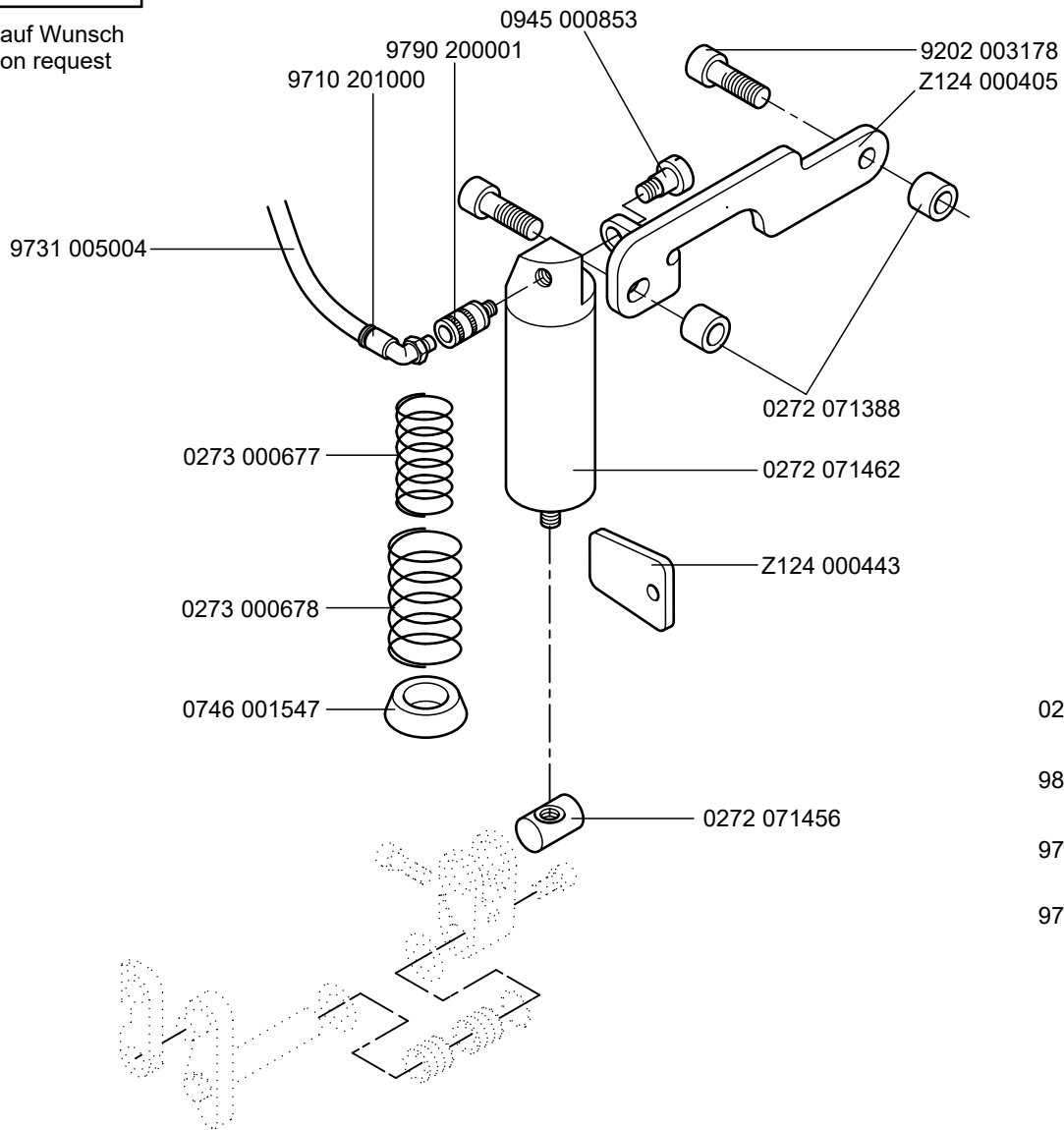

9840 120028



9815 301102

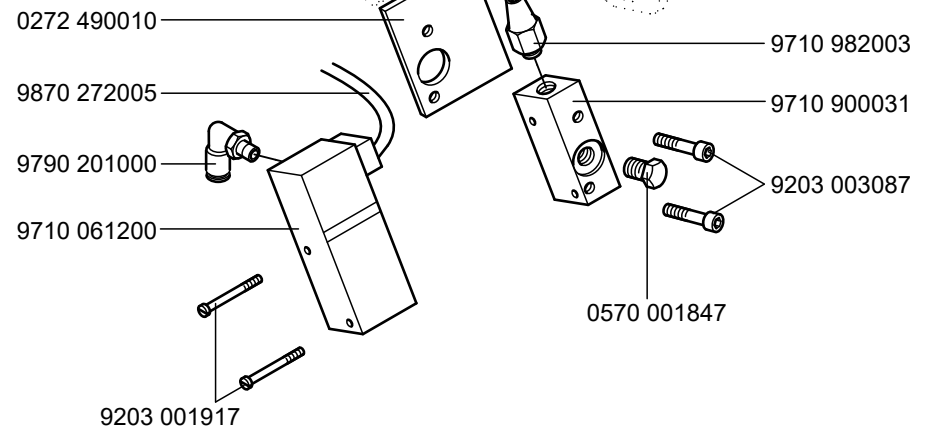
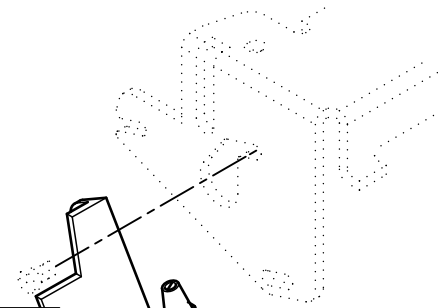

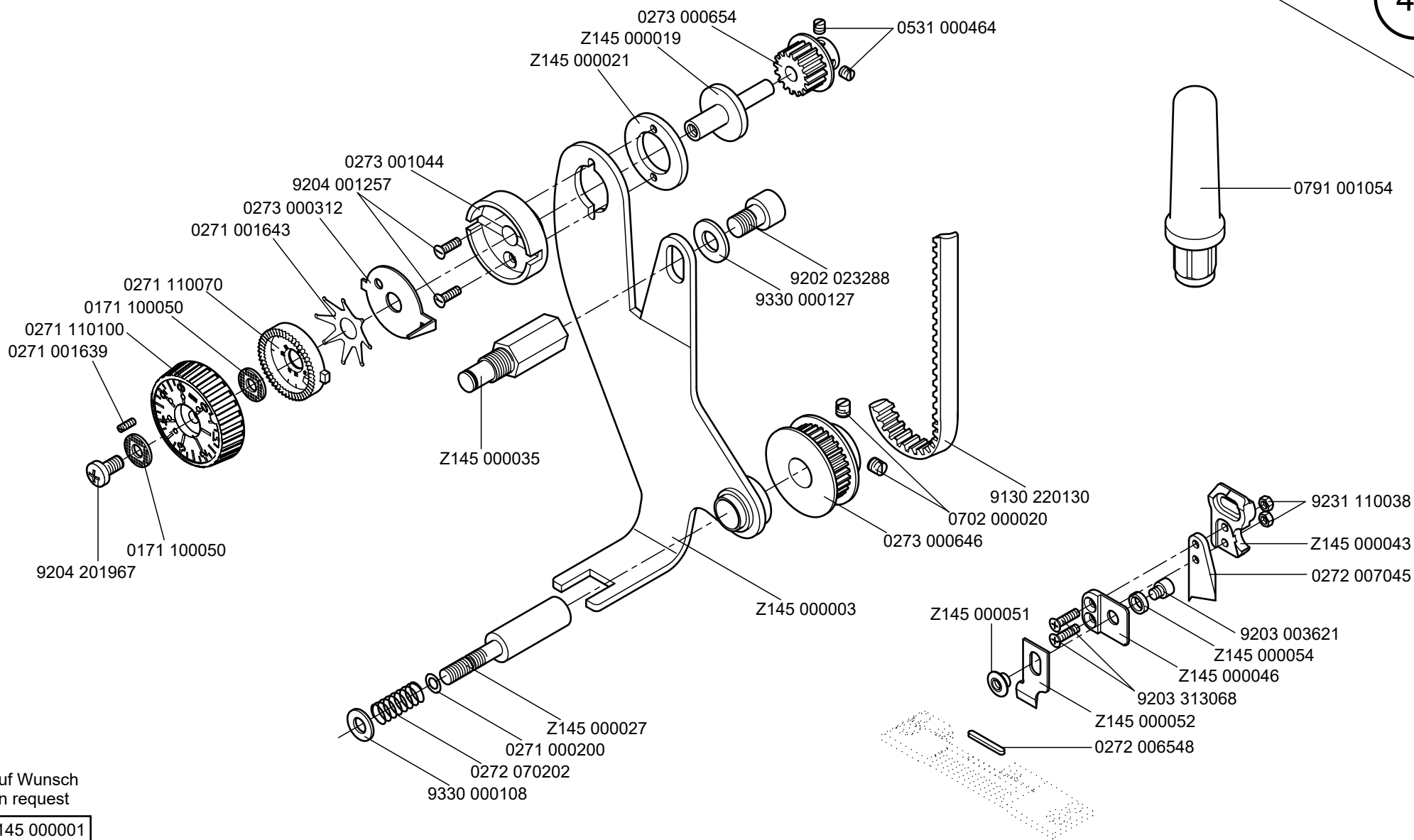

auf Wunsch  
on request

Z145 000001

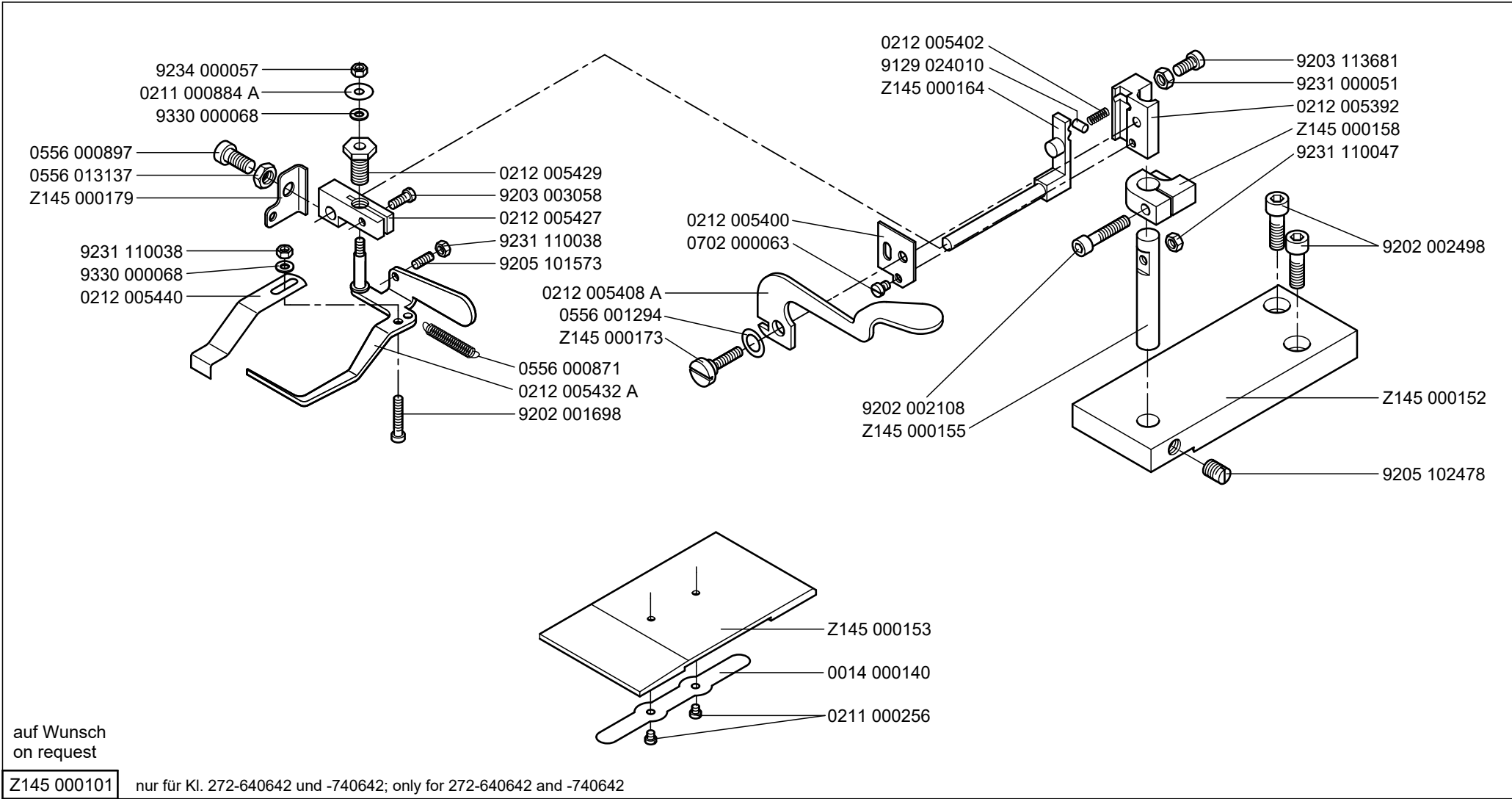

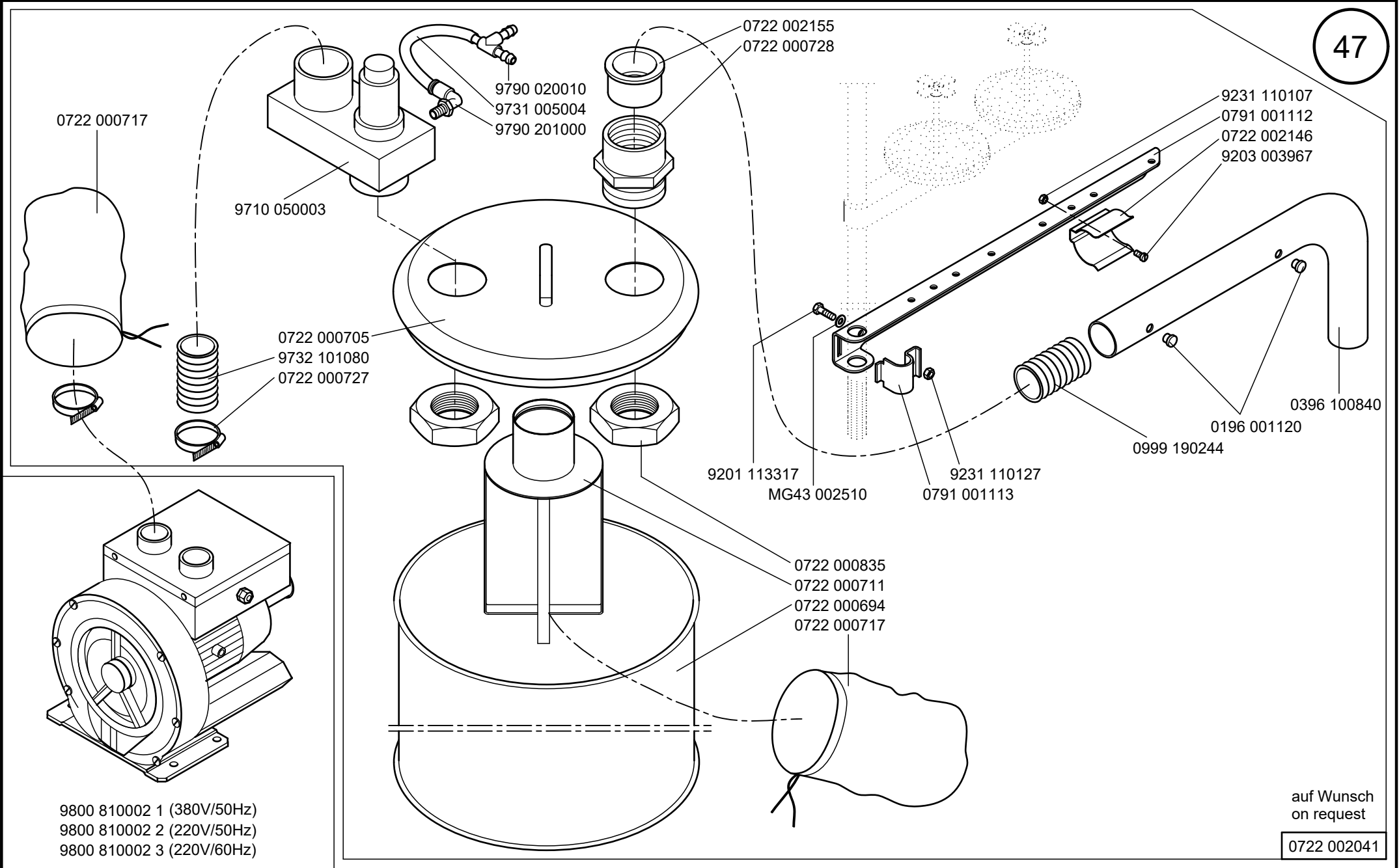

Scale 20%

Cl. 271, 272, 273, 274

letzte Änderung/ last change 03.2009  
Ausgabe/ Edition 06.2025

auf Wunsch  
on request

0722 002041

# CI. 272-160362

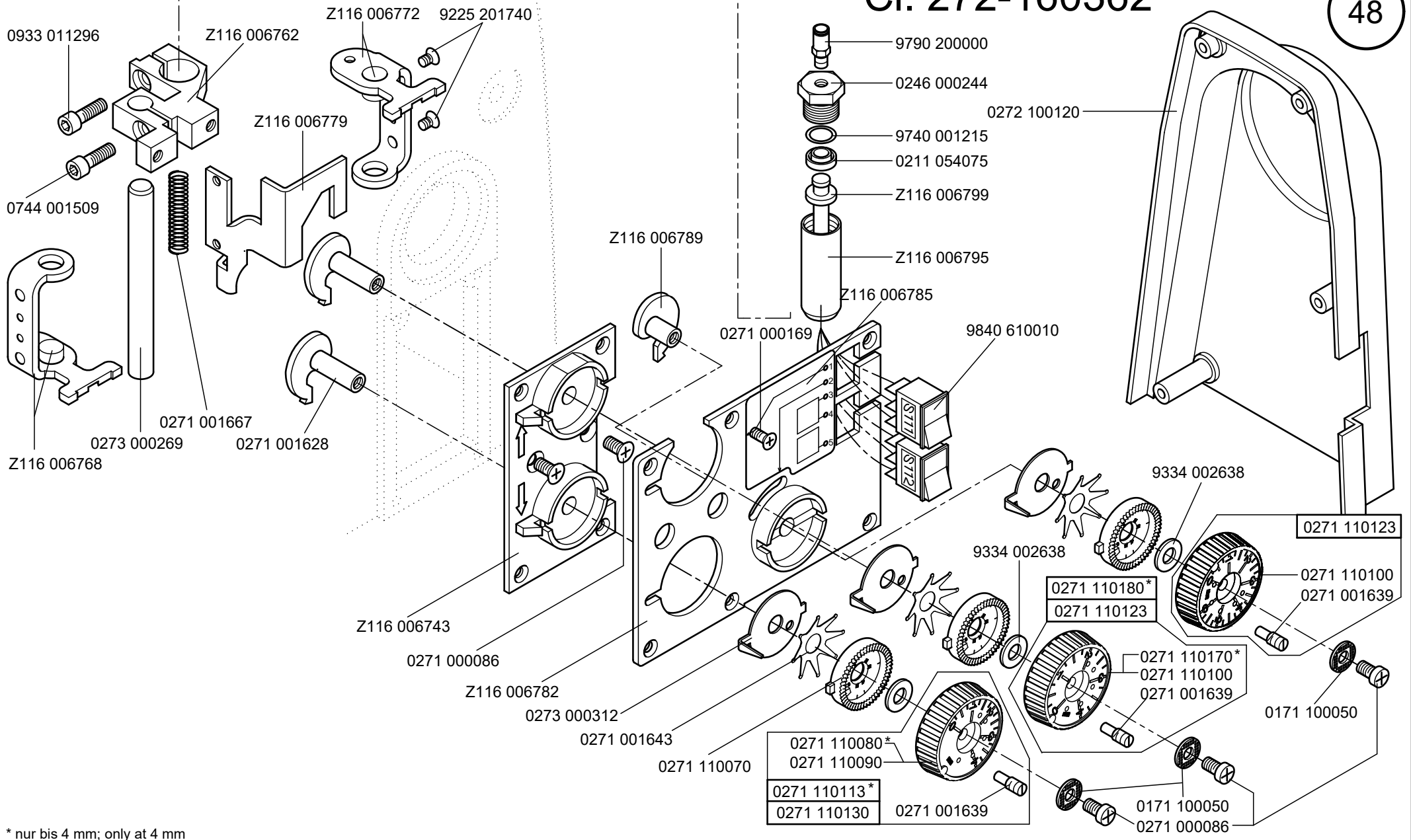

\* nur bis 4 mm; only at 4 mm

Scale 50%

CI. 271, 272, 273, 274

letzte Änderung/ last change 03.2012  
 Ausgabe/ Edition 06.2025

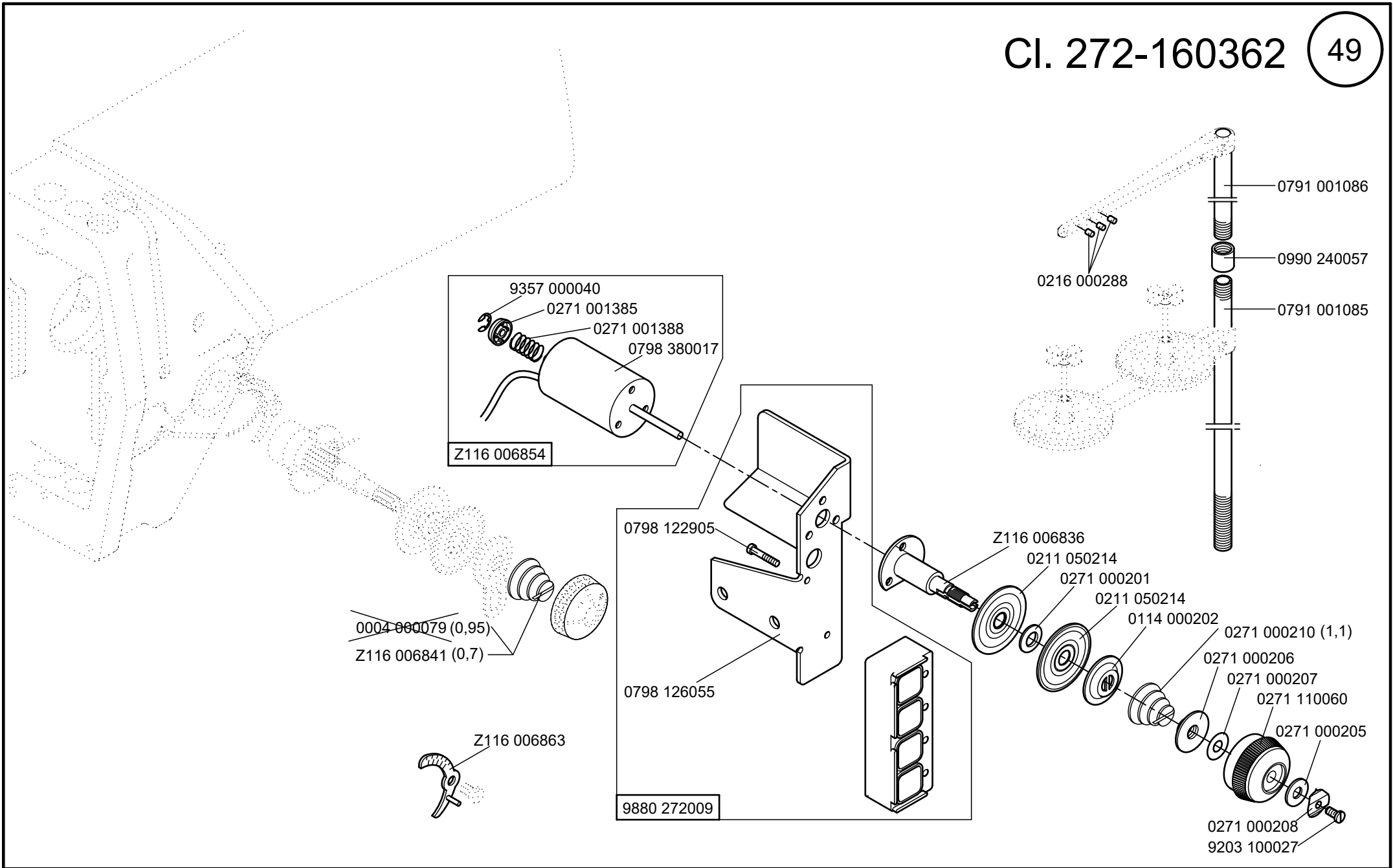

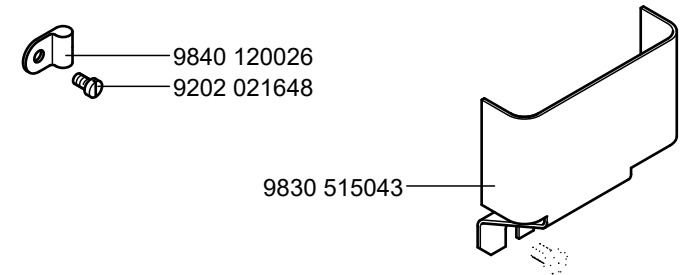
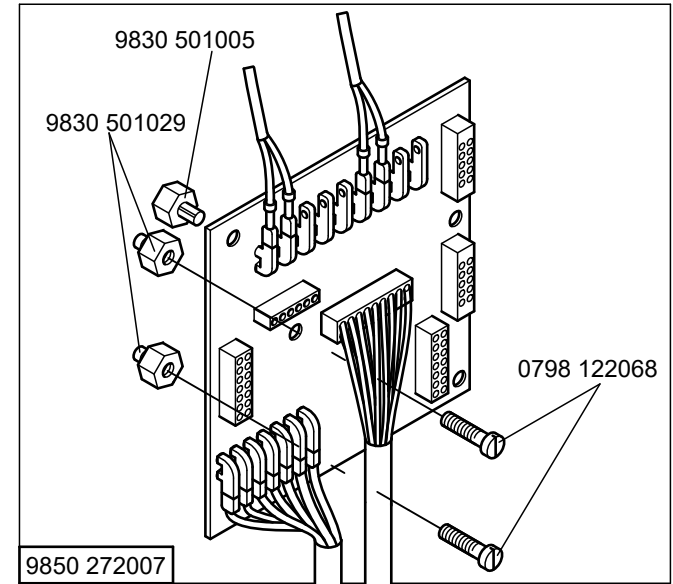
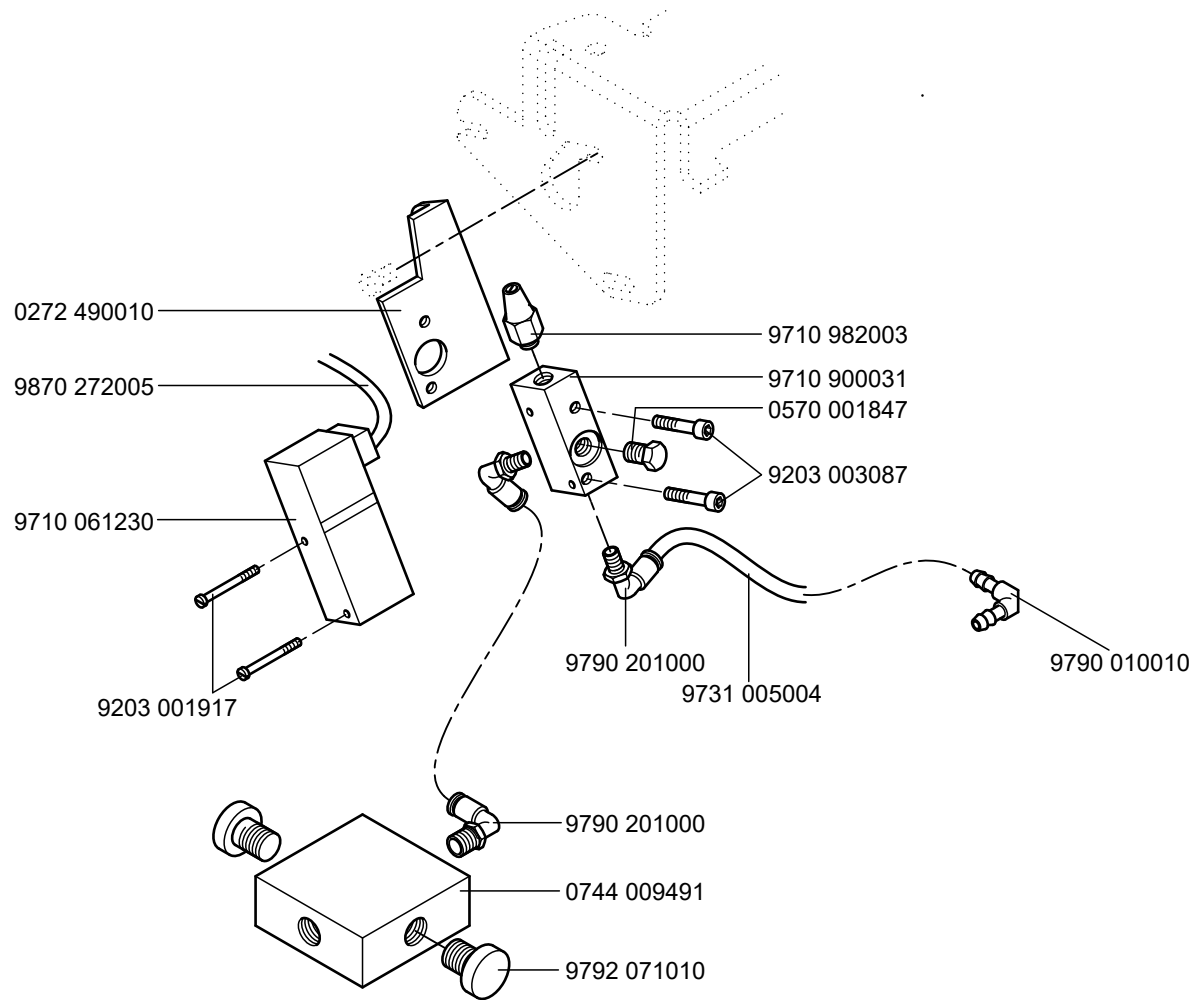

Part No./Teile-Nr.	Table/Tafel	Part No./Teile-Nr.	Table/Tafel	Part No./Teile-Nr.	Table/Tafel	Part No./Teile-Nr.	Table/Tafel
0002 005889 0700	1	0211 000117	2	0211 000699	34	0219 000353	6, 35
0002 007504 8580	37	0211 000133	2, 9	0211 000806	1, 8	0219 000840	4
0002 007504 9500	37	0211 000208	1	0211 000884 A	46	0223 000238	7, 22
0004 000079	3, 21, 49	0211 000208 M4	20	0211 001107	31, 40	0223 000245	9
0014 000140	21, 40, 46	0211 000248	10	0211 001109	31, 40	0223 000450 K	4
0024 000080 A	4	0211 000249	10	0211 001123	40	0223 000454	4
0052 000328	35	0211 000253	10	0211 001124	19, 32, 40	0223 000460 K	4
0069 005844	19, 32	0211 000256	21, 40, 46	0211 001127	31, 40	0223 000481	4
0077 110220	34	0211 000257	10	0211 001129	31, 40	0223 000486	4
0077 110230	34	0211 000302 A	1	0211 008285	7	0223 000646	1, 2, 7, 20, 22, 23
0114 000202	21, 49	0211 000305 A	1, 2, 20, 23	0211 050214	3, 21, 49	0223 000648	1, 6, 19, 22, 26
0147 000203	9, 27	0211 000306 A	1	0211 050215	3		
0171 000248	5	0211 000306 B	1	0211 054075	48		
0171 100040	4	0211 000317 MT	1	0212 000016 B	20, 23	0223 000652	2
0171 100050	12, 26, 29, 30, 45, 48	0211 000331	1, 5	0212 000059 M3	20	0223 000669	9, 21
		0211 000332	1	0212 000102	20, 23	0223 000937	8
0171 100103	3	0211 000339	1, 14	0212 000236	14	0224 000700	7, 22
0171 130010	3	0211 000355	2	0212 000627	2, 9	0231 000453	20
0173 100123	28	0211 000376	1	0212 004821	27	0244 000396	6
0173 340153	27	0211 000381	1	0212 004862	27	0244 000398	6
0173 340173	26	0211 000387	21	0212 005392	46	0244 000400	6
0173 340180	26	0211 000390 K	1	0212 005400	46	0244 000401	6
0196 001120	47	0211 000391 A	1, 20, 21	0212 005402	46	0244 000403	6
0204 000230 A	31	0211 000394	1, 20	0212 005408 A	46	0244 000404	6
0204 000230 A	35	0211 000395	1, 20	0212 005427	46	0244 000414	3, 6
0211 000003	10	0211 000397	1	0212 005429	46	0244 000415	3, 6
0211 000007	10	0211 000398	1, 20	0212 005432 A	46	0244 000501	10
0211 000013	6	0211 000407	1	0212 005440	46	0244 000556 A	19
0211 000014	8	0211 000408	1	0216 000043	3, 26	0244 000558	19
0211 000018	7, 22	0211 000420	5	0216 000052	2	0244 000559 A	19
0211 000022	7, 22	0211 000422	4	0216 000070	7, 22	0244 000561	19
0211 000027	7	0211 000432 A	5	0216 000131	9, 10, 21	0244 000581 A	19
0211 000043	9	0211 000439	5, 14	0216 000134	10, 21	0244 000587 A	19
0211 000045	9	0211 000440	5	0216 000288	6, 39, 49	0244 000588 A	19
0211 000060	9	0211 000459	3	0216 000591	6	0244 000886	8
0211 000062	19	0211 000506	2	0216 000603	6	0244 015012	42
0211 000069	9	0211 000520	6	0216 001146	3	0246 000244	48
0211 000085	9, 15, 19, 21	0211 000644	7	0219 000185	5	0246 000466	6
0211 000088	9	0211 000646 A	7	0219 000193	4	0246 000762	14
0211 000106	2	0211 000648	7	0219 000321	9, 15	0246 100470	2



Part No./Teile-Nr.	Table/Tafel	Part No./Teile-Nr.	Table/Tafel	Part No./Teile-Nr.	Table/Tafel	Part No./Teile-Nr.	Table/Tafel
0249 000342 A	39	0271 000227	3, 29, 30	0271 000648	1, 9	0271 001415	8
0264 000762	10	0271 000236	3	0271 000651	9	0271 001435	8
0265 000138	14	0271 000237	3, 21	0271 000661	4	0271 001452	8
0265 000601	9	0271 000242	6	0271 000667	4	0271 001456	8
0265 000602	9	0271 000245	6	0271 000672	4	0271 001466	8, 11
0265 000753	7	0271 000260	6	0271 000681	4	0271 001472	8
0265 002032	5	0271 000262	6	0271 000682	4	0271 001482	8
0271 000011	3	0271 000273	6	0271 000692	4	0271 001483	8
0271 000026	1	0271 000274	6	0271 000706	16	0271 001485	8
0271 000029	1, 3	0271 000275	6	0271 000756	31, 40	0271 001489	8
0271 000047	3	0271 000298	12	0271 000757	40	0271 001492	7
0271 000050	1	0271 000300	6	0271 000759	31, 40	0271 001493	7
0271 000086	48	0271 000301	6	0271 000893	42	0271 001494	7, 22
0271 000095	1	0271 000308	6, 9	0271 000894	42	0271 001495	7, 22
0271 000096	1	0271 000309	9	0271 000896	42	0271 001497	7
0271 000100	1	0271 000313	9	0271 001062	1	0271 001499	7
0271 000119	1	0271 000316	1	0271 001094	9	0271 001501	7
0271 000120	1	0271 000318	1	0271 001202	6	0271 001508	15, 32
0271 000124	3	0271 000323	1	0271 001203	6	0271 001605	11
0271 000126	1	0271 000324	1	0271 001205	6	0271 001612	11
0271 000162	5	0271 000455	7	0271 001207	6, 11	0271 001622	12
0271 000165	5	0271 000456	7	0271 001212	6	0271 001624	12
0271 000167	5	0271 000462	7, 27	0271 001216	6	0271 001628	12, 48
0271 000169	48	0271 000463	7	0271 001217	6	0271 001639	12, 26, 29,
0271 000185	4	0271 000474	7	0271 001222	6		30, 45, 48
0271 000186	5	0271 000491	7	0271 001232	8	0271 001643	12, 26, 29,
0271 000187	3	0271 000502	2	0271 001237	8		30, 45, 48
0271 000197	3	0271 000516	2	0271 001248	8	0271 001654	12
0271 000199	3	0271 000533	9	0271 001255	9, 11	0271 001655	12
0271 000200	3, 45	0271 000573	9	0271 001382	3	0271 001663	12
0271 000201	3, 21, 49	0271 000574	9	0271 001383	3	0271 001667	12, 48
0271 000205	49	0271 000576	9	0271 001384	3	0271 001671	39
0271 000206	49	0271 000579	9, 21	0271 001385	3, 49	0271 001677	39
0271 000207	49	0271 000580	9, 21	0271 001385 A	3	0271 001681	39
0271 000208	49	0271 000592	7	0271 001388	3, 49	0271 001742	11
0271 000210	49	0271 000593	7	0271 001391	3	0271 001746	11
0271 000212	3	0271 000597	7	0271 001392	3	0271 001747	11
0271 000215	3	0271 000602	7, 27	0271 001397	3, 6	0271 001754	11
0271 000217	3	0271 000604	9	0271 001403	8	0271 001755	11
0271 000222	3	0271 000605	9, 21	0271 001410	8	0271 001763	11

Part No./Teile-Nr.	Table/Tafel	Part No./Teile-Nr.	Table/Tafel	Part No./Teile-Nr.	Table/Tafel	Part No./Teile-Nr.	Table/Tafel
0271 001764	11	0271 120070	5	0272 000141	14	0272 070135	20
0271 001766	11	0271 120080	5	0272 000143	14, 26	0272 070144	20
0271 001767	11	0271 120133	14	0272 000146	14	0272 070153	20
0271 001772	11	0271 130253	5	0272 000151	14	0272 070162	20
0271 001773	11	0271 130260	5	0272 000156	14	0272 070166	20
0271 001991	40	0271 130280	5	0272 000157	14	0272 070168	20
0271 002003	40	0271 130290	5	0272 000191	14	0272 070173	20
0271 002005	40	0271 130294	5	0272 000193	14	0272 070177	20
0271 002091	19, 32	0271 130310	5	0272 000196	14	0272 070193	20
0271 002096	19, 32	0271 150034	31	0272 000202	14	0272 070197	20
0271 002097	19	0271 150040	31	0272 000203	14	0272 070198	20
0271 002103	19, 32, 35	0271 150054	31	0272 000215	14	0272 070202	20, 45
0271 002105	19, 32	0271 150060	31	0272 000217	14	0272 070210	20
0271 002114	19, 32	0271 150070	31	0272 000222	15	0272 070216	20
0271 002117	19, 32	0271 150080	31	0272 000234	15	0272 070219	20
0271 002118	19, 32	0271 150090	31	0272 000235	15	0272 070222	20
0271 002119	19, 32	0271 150104	2	0272 000237	15	0272 070225	20
0271 002121	32	0271 150110	16	0272 000602	15	0272 070233	20
0271 100090	1	0271 150124	31	0272 000613	15	0272 070294	21
0271 100164	1	0271 150173	17, 18	0272 000614	15	0272 070306	21
0271 100244	3	0271 160024	7	0272 000617	15	0272 070342	21
0271 100350	10	0271 380010	16	0272 000702	9	0272 070353	21
0271 100360	10	0271 490010	16	0272 000708	15	0272 070369	21
0271 100380	3	0271 490030	16	0272 000709	15	0272 070401	21
0271 100390	39	0271 490050	42	0272 001395	22	0272 070455	20
0271 100410	6	0271 490060	42	0272 002048	15, 32	0272 070458	20
0271 110040	3	0271 490080	38	0272 002049	15, 32	0272 070877	21
0271 110060	49	0271 490090	38	0272 002422	12	0272 070878	21
0271 110070	12, 26, 29, 30, 45, 48	0271 590024	42	0272 006548	45	0272 070895	21
		0271 590034	40	0272 007042	20	0272 070898	21
0271 110080	12, 48	0271 590044	38	0272 007045	35, 45	0272 070902	21
0271 110090	12, 48	0272 000016	14	0272 070019	20, 23	0272 071044	21
0271 110100	12, 45, 48	0272 000128	14	0272 070032	20, 23	0272 071045	21
0271 110113	48	0272 000129	14	0272 070068	20	0272 071046	21
0271 110123	48	0272 000135	14	0272 070103	20	0272 071071	22
0271 110130	48	0272 000137	14	0272 070115	20	0272 071311	23
0271 110140	29, 30	0272 000138	14	0272 070117	20	0272 071318	23
0271 110153	29, 30	0272 000138 A	14	0272 070123	20	0272 071353	23
0271 110170	12, 48	0272 000138 B	14	0272 070124	20	0272 071364	23
0271 110180	48	0272 000138 C	14	0272 070126	20	0272 071374	23

Part No./Teile-Nr.	Table/Tafel	Part No./Teile-Nr.	Table/Tafel	Part No./Teile-Nr.	Table/Tafel	Part No./Teile-Nr.	Table/Tafel
0272 071380	23	0273 000321	26	0273 000662	28	0540 100830	3
0272 071383	23	0273 000322	26	0273 000663	28	0540 100850	5
0272 071387	23	0273 000324	28	0273 000675	28	0540 110080	3, 21
0272 071388	23, 44	0273 000325	23, 26	0273 000677	23, 28, 44	0556 000148	1, 5, 14, 42
0272 071394	23	0273 000342	6	0273 000678	23, 28, 44	0556 000230	15, 19
0272 071396	23	0273 000345	6	0273 000680	28	0556 000871	46
0272 071456	23, 44	0273 000463	27	0273 000683	28	0556 000895	8, 28, 41, 43
0272 071462	23, 44	0273 000465	27	0273 000686	28	0556 000897	46
0272 076064	22	0273 000469	27	0273 000697	27	0556 001294	46
0272 076093	22	0273 000472	27	0273 001041	29	0556 003011	20
0272 076153	22	0273 000478	27	0273 001043	29	0556 003087	8
0272 076157	22	0273 000506	27	0273 001044	45	0556 003088	8
0272 076159	22	0273 000515	27	0273 001046	29	0556 005040	9, 21
0272 076279	22	0273 000521	27	0273 001055	29	0556 013137	46
0272 076374	24	0273 000524	27	0273 001057	29	0569 006884	14, 21
0272 076375	24	0273 000530	27	0273 002511	28	0570 000055	2, 9
0272 100110	3	0273 000534	27	0273 002518	26	0570 000623	9
0272 100120	48	0273 000542	27	0273 100040	29, 30	0570 001249	19, 32, 40
0272 350070	20	0273 000552	27	0273 130010	5	0570 001252	40
0272 350080	20	0273 000555	28	0273 340020	27	0570 001254	19, 32, 40
0272 380010	35	0273 000557	28	0274 000193	14	0570 001255	31
0272 490010	25, 44, 50	0273 000562	28	0274 001141	30	0570 001847	25, 44, 50
0273 000006	1, 26	0273 000572	28	0274 001143	30	0570 010007	1, 14, 21
0273 000163	5	0273 000576	28	0274 001146	30	0620 760092	6, 8, 9, 15, 19, 21
0273 000180	5	0273 000583	28	0274 001158	30	0650 000045	6
0273 000244	1, 26	0273 000587	28	0275 120014	1	0650 000292	6
0273 000248	26	0273 000589	28	0275 380020	1	0667 145400	4
0273 000256	26	0273 000590	28	0275 380050	35	0700 000043	33
0273 000257	26	0273 000596	28	0281 150084	31	0700 000044	33
0273 000262	26	0273 000599	28	0281 150190	31	0700 000045	33
0273 000267	26	0273 000600	28	0281 380114	34	0700 000050	33
0273 000269	48	0273 000606	28	0291 000159	1, 5, 14, 21	0700 000090	34
0273 000272	26	0273 000615	28	0291 000178 M3	4	0700 027112	33
0273 000283	26	0273 000620	28, 35	0291 000347	11	0700 027113	33
0273 000293	26	0273 000629	28	0291 000516	39	0700 027114	33
0273 000295	26	0273 000637	28	0367 115250	3	0702 000020	27, 45
0273 000297	26	0273 000645	27	0367 135014	4	0702 000063	7, 46
0273 000307	26	0273 000646	27, 45	0396 100840	47	0722 000694	47
0273 000312	26, 29, 30, 45, 48	0273 000653	28	0396 155830	19, 32	0722 000705	47
		0273 000654	28, 45	0531 000464	10, 28, 45		

Part No./Teile-Nr.	Table/Tafel	Part No./Teile-Nr.	Table/Tafel	Part No./Teile-Nr.	Table/Tafel	Part No./Teile-Nr.	Table/Tafel
0722 000711	47	0791 001112	47	0933 001555	10	9041 100035	3, 7,15,22
0722 000717	47	0791 001113	47	0933 001556	10	9041 100050	1
0722 000727	47	0791 001200	34	0933 005621	27	9041 102025	1, 9, 15, 19, 21, 26
0722 000728	47	0791 007821	35	0933 005622	27	9041 102035	15
0722 000835	47	0791 271504	34, 35	0933 005623	27	9050 050001	8
0722 002041	47	0791 272505	34, 35	0933 005724	28	9081 200250	34
0722 002146	47	0791 272506	34, 35	0933 005725	28	9081 500010	34
0722 002155	47	0791 273502	34, 35	0933 005736	28	9081 500051	34
0723 000013	27	0791 580100	34	0933 005737 A	28, 35	9120 030050	8
0739 000347	8	0792 008065	26, 28	0933 005738	28	9120 030080	7
0742 002096	36	0793 003508	22	0933 005738 A	28	9120 030081	7
0742 041517	28	0797 002016	43	0933 011296	48	9120 030121	2
0742 041524	28	0797 002017	43	0933 063984	8	9120 050120	27
0744 001155	35	0797 003031	36	0939 002868	21	9120 080250	1
0744 001369	28	0798 120401	38	0945 000816	35	9122 210081	20
0744 001509	48	0798 122068	24, 50	0945 000853	23, 28, 44	9129 016060	1
0744 001793 A	36	0798 122905	13, 49	0990 240057	49	9129 020180	6
0744 001793 B	36	0798 123916	24	0990 490128	35	9129 024010	46
0744 001796	36	0798 124920	13	0992 017500	19, 32	9129 024030	6
0744 001801 B	3	0798 126055	49	0992 017520	19, 32	9130 202190	16
0744 009491	50	0798 126073	24	0992 023910	19, 32	9130 220120	27
0746 000789	27	0798 221025	37	0993 087108	24	9130 220130	28, 45
0746 001482	8, 41	0798 221026	24	0993 087138	24	9201 112877	16
0746 001547	23, 28, 44	0798 380017	49	0993 941028	28	9201 113317	47
0748 000294	9	0798 421007	41	0995 340617	34	9201 113677	4
0791 000007	34	0798 447914	37	0999 190244	47	9202 001658	27
0791 000009	35	0798 500088	37	0999 202637	13	9202 001698	46
0791 001011	34	0798 709021	41	0999 220848	43	9202 002057	28
0791 001012	34	0798 709040	43	0999 240303	36	9202 002063	20, 23
0791 001053	35	0867 110463	3	0999 240341	36	9202 002073	20
0791 001054	45	0867 110490	3	0APP 001041	37	9202 002083	19, 20, 27, 28
0791 001081	34	0867 110520	3	0APP 001042	37	9202 002093	20
0791 001084	34	0902 000623	14	1001 001162	5, 15	9202 002108	46
0791 001085	49	0902 000670	20	1001 003102	6	9202 002377	27, 28
0791 001086	49	0911 000339	43	1001 009140	4	9202 002467	23
0791 001090	34	0931 002092	28	1001 009148	29	9202 002473	1
0791 001091	34	0933 000075	1	9041 100015	26	9202 002483	9
0791 001093 A	1	0933 001533	6	9041 100025	3, 8, 9, 14, 26	9202 002488	1, 8, 9, 20, 21, 23, 27, 28
0791 001093 A	34	0933 001545	10	9041 100030	1, 6, 9, 15,		
0791 001095	34	0933 001546	10		19, 21		

Part No./Teile-Nr.	Table/Tafel	Part No./Teile-Nr.	Table/Tafel	Part No./Teile-Nr.	Table/Tafel	Part No./Teile-Nr.	Table/Tafel
9202 002493	12, 15	9203 113681	46	9205 024358	4	9330 000068	20, 27, 41,
9202 002497	39	9203 113983	3	9205 024857	7		42, 43, 46
9202 002498	46	9203 312411	1, 5, 14, 15,	9205 101573	46	9330 000087	3, 28, 38
9202 002537	16		21, 32	9205 101888	20	9330 000088	35
9202 002558	10	9203 313021	42	9205 102168	20	9330 000097	8, 11, 16, 20,
9202 002897	9	9203 313048	21	9205 102178	3		26, 41
9202 002903	9	9203 313068	45	9205 102473	23	9330 000098	7, 43
9202 002918	11, 26	9203 313671	5, 14, 26	9205 102478	1, 46	9330 000108	45
9202 002937	36	9203 313681	29	9205 102508	14	9330 000127	33, 45
9202 003008	10	9204 001257	29, 40, 45	9205 102783	16, 17, 18	9330 000167	36
9202 003178	23, 44	9204 001258	30	9205 102787	2, 4	9330 000177	34
9202 003317	37	9204 001767	9	9205 102808	1	9330 200098	8, 10
9202 003347	37	9204 002473	1	9206 100637	8	9330 200137	10
9202 003737	10	9204 101667	6, 20	9206 200097	33	9330 900088	28
9202 021648	50	9204 201647	38	9207 160957	34	9330 900097	38
9202 022078	20	9204 201648	1, 3, 10, 23,	9207 161267	34	9330 900098	8
9202 023288	45		24	9207 170227	33, 35, 37, 38	9333 000090	8
9202 042887	16	9204 201658	3, 10, 11, 13,	9207 170437	37	9334 001640	20
9202 100338	28		14, 22, 41	9217 300518	6, 23	9334 002638	12, 26, 48
9203 001917	25, 44, 50	9204 201667	3	9217 300528	3, 28	9352 000060	6
9203 003027	14	9204 201668	8	9225 201740	7, 48	9352 000090	14, 21
9203 003037	20	9204 201677	3, 17, 38	9231 000051	35, 46	9352 000120	2, 28
9203 003058	46	9204 201678	15	9231 000378	6, 28	9353 000140	7
9203 003087	25, 44, 50	9204 201693	2	9231 011133	1, 9	9353 000280	27
9203 003101	26	9204 201698	8, 30	9231 011137	4	9354 010020	6
9203 003621	45	9204 201701	41, 42, 43	9231 110037	24	9354 010240	2
9203 003627	13	9204 201711	38	9231 110038	29, 30, 41,	9357 000040	43, 49
9203 003653	1	9204 201723	6, 26		43, 45, 46	9357 000050	43
9203 003657	37	9204 201727	26	9231 110047	46	9357 000060	8, 11, 27, 28,
9203 003667	13	9204 201767	2	9231 110058	6, 8		41
9203 003678	14	9204 201827	8	9231 110107	10, 11, 47	9357 000070	5, 6, 8, 9, 11,
9203 003967	47	9204 201958	7, 11, 13, 24	9231 110108	28		14, 15, 28
9203 003977	11	9204 201967	12, 29, 30, 45	9231 110127	9, 47	9357 000080	4, 9, 11, 21
9203 003997	20	9204 201968	11, 43	9231 110128	4, 10	9357 000090	4, 5, 6, 11
9203 004288	11	9204 201977	1	9231 110137	4	9357 000100	4
9203 100002	41, 43	9204 202038	34	9234 000057	46	9357 000110	27
9203 100027	42, 49	9204 202268	16	9237 900001	26	9380 521220	4
9203 100631	5, 10, 21	9204 311507	24	9301 022608	34	9401 000194	17
9203 100632	14	9205 023641	5	9301 103231	12	9401 000204	17
9203 113671	3	9205 023658	6			9710 020040	43

Part No./Teile-Nr.	Table/Tafel	Part No./Teile-Nr.	Table/Tafel	Part No./Teile-Nr.	Table/Tafel	Part No./Teile-Nr.	Table/Tafel
9710 050003	47	9800 560001	23	9840 120031	13	MG43 000484	18
9710 061100	43	9800 760001	23	9840 120060	34	MG43 002510	47
9710 061200	25, 44	9800 810002 1	47	9840 121001	34	MG53 000501	33
9710 061230	50	9800 810002 2	47	9840 123003	37	MG53 002501	33
9710 201000	44	9800 810002 3	47	9840 131001	37	MG53 007511	33
9710 900031	25, 44, 50	9805 300001	24	9840 133002	37	MG53 007921	36
9710 920013	23	9815 114001	24	9840 133004	37	MG53 007922	36
9710 982003	25, 44, 50	9815 301102	44	9840 133012	37	MG53 400015	33
9731 001030	9, 21	9815 915001	40	9840 134001	37	MG53 400016	33
9731 001035	6	9815 920017	42	9840 135002	37	MG53 400017	33
9731 001045	6, 8	9820 110037	3	9840 135012	37	Z116 006743	48
9731 002001	36	9822 510000	37	9840 610010	48	Z116 006762	48
9731 004035	9	9822 510001	37	9840 730016	41	Z116 006768	48
9731 005004	35, 43, 44, 47, 50	9822 510002	37	9850 001083	37, 38	Z116 006772	48
		9822 510003	37	9850 001309	17	Z116 006779	48
9731 006004	43	9822 510011	37	9850 001311	17	Z116 006782	48
9731 007035	7, 21, 22	9822 510012	37	9850 001340	17	Z116 006785	48
9731 102025	9	9822 510013	37	9850 271002	13	Z116 006789	48
9732 101080	47	9822 560000	38	9850 272003	24	Z116 006795	48
9740 000731	20	9822 560011	37	9850 272005	24	Z116 006799	48
9740 000803	5	9822 560041	37	9850 272007	50	Z116 006836	49
9740 001215	48	9822 610000	37	9850 272008	24	Z116 006854	49
9740 001220	3	9822 642024	37	9870 001108	34	Z116 006863	49
9780 000108	36	9822 642027	37	9870 271001	8	Z120 001801	41
9781 000002	36	9825 810215	18	9870 271004	13	Z120 001804	41
9790 010010	50	9825 810302	37	9870 272004	24	Z120 001807	41, 43
9790 020010	47	9825 810409	18	9870 272005	44, 50	Z120 001810	41
9790 101010	23	9825 830223	18	9870 272006	24, 50	Z120 001811	41, 43
9790 200000	48	9830 400125	24	9870 273001	13	Z120 001813	41
9790 200001	35, 44	9830 501005	24, 50	9870 382003	27	Z120 001815	41, 43
9790 201000	25, 28, 44, 47, 50	9830 501029	24, 50	9880 001005	17	Z120 001817	41
		9830 515031	13	9880 001020	37	Z120 001820	41, 43
9792 071010	50	9830 515043	50	9880 271004	13	Z120 001821	41
9792 350002	5	9830 515065	17	9880 271005	13	Z120 001826	41
9800 170026 R	18	9840 101005	37	9880 272003	13	Z120 001828	41
9800 170038	17, 18	9840 104011	8	9880 272008	24	Z120 001841	41
9800 210001 R	17	9840 120001	37	9880 272009	49	Z120 001844	41
9800 360101	18	9840 120026	3, 50	9880 272010	24	Z120 001851	43
9800 370000	18	9840 120027	13, 37, 38, 41	9880 273002	13	Z120 001854	43
9800 370001	18	9840 120028	13, 44	MG43 000062	33	Z120 001862	43

Part No./Teile-Nr.	Table/Tafel	Part No./Teile-Nr.	Table/Tafel	Part No./Teile-Nr.	Table/Tafel	Part No./Teile-Nr.	Table/Tafel
Z120 001872	43						
Z120 001884	43						
Z120 001887	43						
Z124 000405	44						
Z124 000443	23, 35, 44						
Z124 000501	44						
Z125 000118	27						
Z134 000325	40						
Z134 000332	40						
Z145 000001	45						
Z145 000003	45						
Z145 000019	45						
Z145 000021	45						
Z145 000027	45						
Z145 000035	45						
Z145 000043	45						
Z145 000046	45						
Z145 000051	45						
Z145 000052	45						
Z145 000054	45						
Z145 000101	46						
Z145 000152	46						
Z145 000153	46						
Z145 000155	46						
Z145 000158	46						
Z145 000164	46						
Z145 000173	46						
Z145 000179	46						

E-Nr. E-No.	Für Unterklassen/For subclasses	Nadelhalter Needle holder				Stichplatte Throat plate			Haupt-Transporteur Main feed dog			Presserfuß Presser foot			Greifer Hook					
		Nadelabstand/ Needle distance [mm]	Nadelhalter/ Needle holder	Nadelhalter, links/ Needle holder, left	Nadelhalter, rechts/ Needle holder, right	Stichlochgröße/ Stitch hole size [mm]	Stichplatte/ Throat plate	Schieber, links/ Slide, left	Schieber, rechts/ Slide, right	Stichlochgröße/ Stitch hole size [mm]	Sägeverzahn/ Serrated [mm]	Säge-schrägverzahn/ Serrated, oblique [mm]	Kreuzverzahn/ Cross toothed [mm]	Dachverzahn/ Roof-shaped [mm]	Fester Fuß/Foot, rigid	Gelenkfuß/Foot, articulated	Hebel-Gelenkfuß/Foot, articulated, with lever	Tandemgelenkfuß	Nadelschutz	Nadelsystem/ Needle system
E2	-140041; -140042; -140341; -140442  Allgemeine Näharbeiten für leichtes Nähgut mit Gelenkfuß. Max. Stichlänge 4mm  General stitching operations in leight weight material with articulated foot. Stitch length max. 4mm					ø 1,5	0211 004521			0271 006602; 1,6					0204 000052					134/ 80
E3	-140041; -140042; -140341; -140442  Allgemeine Näharbeiten für mittelschweres Nähgut mit Gelenkfuß. Max. Stichlänge 4mm  General stitching operations in medium weight material with articulated foot. Stitch length max. 4mm					ø 1,8	0211 001491			0271 006603; 2,0					0204 000078					134/ 100
E4	-140041; -140042; -140341; -140442  Näheinrichtung zum Kantensteppen, Anschlag 0,8mm rechts der Nadel in sehr leichtem und leichtem Nähgut mit gefedertem Ausgleichgelenkfuß Max. Stichlänge 3mm  Sewing equipment for stitching on edges, guide 0,8mm on the right of the needle in very light and light weight material with springy articul. compens. foot. Stitch length max. 3mm					ø 1,5	0271 006504			0271 006601; 1,2					0204 001322					134/ 80



E-Nr. E-No.	Für Unterklassen/For subclasses	Nadelhalter Needle holder				Stichplatte Throat plate			Haupt-Transporteur Main feed dog			Presserfuß Presser foot			Greifer Hook							
		Nadelabstand/ Needle distance [mm]	Nadelhalter/ Needle holder	Nadelhalter, links/ Needle holder, left	Nadelhalter, rechts/ Needle holder, right	Stichlochgröße/ Stitch hole size [mm]	Stichplatte/ Throat plate	Schieber, links/ Slide, left	Schieber, rechts/ Slide, right	Stichlochgröße/ Stitch hole size [mm]	Sägeverzahn/ Serrated [mm]	Säge-schrägverzahn/ Serrated, oblique [mm]	Kreuzverzahn/ Cross toothed [mm]	Dachverzahn/ Roof-shaped [mm]	Säumerfuß/ Foot, hemming	Gelenkfuß/Foot, articulated	Rollfuß/ Foot, roller	Tandemgelenkfuß	Nadelschutz	Lineal/ Guide	Nadelsystem/ Needle system	
E13	-140041; -140042; -140341; -140342; -140442  Näheinrichtung zum Einnähen von Reißverschlüssen, Reißverschlusskette links oder rechts in sehr leichtem Nähgut. Max. Stichtlänge 3mm  Sewing equipment for inserting zipper chain on the left or on the right of the food sole in very light and light weight material. Stitch length max. 3mm														0211 001331							134/ 80
E15	-140041; -140042; -140341; -140342; -140442  Allgemeine Näharbeiten mit Rollfuß in leichtem Leder. Rolle 4mm breit, ø21mm Perlrändelung. Max. Stichtlänge 4mm  General stitching operations, with roller foot, for light weight leather, 4mm wide roller, ø21mm, knurled. Stitching length max. 4mm															0271 006815						797 LR/ 90
E18	-140040; -140041; -140042; -150046; -150047  Allgemeine Näharbeiten in mittelschwerem Nähgut, z.B. Jeans. Max. Stichtlänge 4mm  General stitching operations in medium weight material, e.g. denim. Max. stitch length 4mm															0204 000078						134/ 110



E-Nr. E-No.	Für Unterklassen/For subclasses	Nadelhalter Needle holder				Stichplatte Throat plate		Haupt-Transporteur Main feed dog			Presserfuß Presser foot			Greifer Hook								
		Nadelabstand/ Needle distance [mm]	Nadelhalter/ Needle holder	Nadelhalter, links/ Needle holder, left	Nadelhalter, rechts/ Needle holder, right	Stichlochgröße/ Stitch hole size [mm]	Stichplatte/ Throat plate	Schieber, links/ Slide, left	Schieber, rechts/ Slide, right	Stichlochgröße/ Stitch hole size [mm]	Sägeverzahn/ Serrated [mm]	Säge-schrägverzahn/ Serrated, oblique [mm]	Kreuzverzahn/ Cross toothed [mm]	Dachverzahn/ Roof-shaped [mm]	Säumerfuß/ Foot, hemming	Gelenkfuß/Foot, articulated	Ausgleichsgelenkfuß/ Foot articul. compens.	Ausgleichsgelenkfuß/ Foot articul. compens.	Abdeckplatte/ ...plate	Lineal/ Guide	Nadelsystem/ Needle system	
E30	-140042; -140341; -140342; -140442  Näheinrichtung zum Abnähen von Ärmelschlitzecken am Blazer und Sakko in leichtem bis mittelschwerem Nähgut. Max. Stichlänge 4mm  Sewing equipment for pre-stitching sleeve vent corners on blazer and jackets in light to medium weight material. Stitch length max. 4mm					2,7 x 1,8	0211 001491															134/ 100
E31	-140341; -140342  Näheinrichtung für den Arbeitsgang "Spitzfasson vornähen mit Klappschablonen" in leichtem Nähgut. Max. Stichlänge 4mm  Sewing equipment for the operation "sewing and trimming of peak labels and small parts with template" in light weight material. Stitching length max. 4mm					2,7 x 1,8	0271 006521								0211 0001452 K				0271 007048			134/ 80
E60	-140331; -140332; -140432  Näheinrichtung für sehr leichtes bis leichtes Nähgut. Max. Stichlänge 4mm  Sewing equipment for very light to light weight material. Stitch length max. 4mm					ø 1,2	0271 006522								0271 006858							134 SAN 10 – 70

E-Nr. E-No.	Für Unterklassen/For subclasses	Nadelhalter Needle holder				Stichplatte Throat plate		Haupt-Transporteur Main feed dog			Presserfuß Presser foot		Greifer Hook									
		Nadelabstand/ Needle distance [mm]	Nadelhalter/ Needle holder	Nadelhalter, links/ Needle holder, left	Nadelhalter, rechts/ Needle holder, right	Stichlochgröße/ Stitch hole size [mm]	Stichplatte/ Throat plate	Schieber, links/ Slide, left	Schieber, rechts/ Slide, right	Stichlochgröße/ Stitch hole size [mm]	Sägeverzahn/ Serrated [mm]	Säge-schrägverzahn/ Serrated, oblique [mm]	Kreuzverzahn/ Cross toothed [mm]	Dachverzahn/ Roof-shaped [mm]	Säumerfuß/ Foot, hemming	Gelenkfuß/Foot, articulated	Ausgleichsgelenkfuß/ Foot articul. compens.	Ausgleichsgelenkfuß/ Foot articul. compens.	Abdeckplatte/ ...plate	Lineal/ Guide	Nadelsystem/ Needle system	
E62	-140331; -140332; -140432  Näheinrichtung mit Vorsatzsäumer für sehr leichtes bis leichtes Nähgut nach N001 und N005. Max. Stichlänge 4mm  Sewing equipment with hemmer for very light to light weight material according to N001 and N005. Stitch length max. 4mm					ø 1,2	0275 200130			0275 210090; 1,2					0204 000850							134 SAN 10 – 70
E64	-140331; -140332; -140432  Näheinrichtung für Säumarbeiten. Saumbreite 2mm. Nach N005, für sehr leichtes Nähgut, mit Säumerfuß. Max. Stichlänge 4mm  Sewing equipment for hemming. Hem width 2mm. For very light weight material, according to N005, with hemming foot. Stitch length max. 4mm					ø 1,2	0271 006523			0271 006619; 1,2				0204 002520 A1A								134 SAN 10 – 70
E66	-140331; -140332; -140432  Näheinrichtung zum Annähen der Schulterpassen an das Hemdenvorderteil. Nach N514, für sehr leichtes Nähgut. Max. Stichlänge 3mm  Sewing equipment for attaching the yoke to the shirt front according to N514. For very light weight material. Stitching length max. 3mm					ø 1,2	0271 006525			0275 210090; 1,2						0271 006818						134 SAN 10 – 70

E-Nr. E-No.	Für Unterklassen/For subclasses	Nadelhalter Needle holder				Stichplatte Throat plate		Haupt-Transporteur Main feed dog			Presserfuß Presser foot		Greifer Hook										
		Nadelabstand/ Needle distance [mm]	Nadelhalter/ Needle holder	Nadelhalter, links/ Needle holder, left	Nadelhalter, rechts/ Needle holder, right	Stichlochgröße/ Stitch hole size [mm]	Stichplatte/ Throat plate	Schieber, links/ Slide, left	Schieber, rechts/ Slide, right	Stichlochgröße/ Stitch hole size [mm]	Sägeverzahn/ Serrated [mm]	Säge-schrägverzahn/ Serrated, oblique [mm]	Kreuzverzahn/ Cross toothed [mm]	Dachverzahn/ Roof-shaped [mm]	Säumerfuß/ Foot, hemming	Gelenkfuß/Foot, articulated	Ausgleichsgelenkfuß/ Foot articul. compens.	Ausgleichsgelenkfuß/ Foot articul. compens.	Abdeckplatte/ ...plate	Lineal/ Guide	Nadelsystem/ Needle system		
E68	-140331; -140332; -140432																						
Abb. Nr. Fig. No.	Verwendungszweck/Use																						
	<p>Näheinrichtung zum Einfassen mit mitgehendem Einfasser. Nach N015, für sehr leichtes Nähgut. Nur in Verbindung mit Bausatz N900 003441 und Einfasser. Max. Stichtlänge 4mm</p> <p>Sewing equipment for binding operations with go along binder. For very light weight material, according to N015. Use only in combination with the kit N900 003441 and a binder. Stitch length max. 4mm</p>				ø 1,2	0271 006524				0271 006620; 1,2					0204 000886								134 SAN 10 – 70

E2

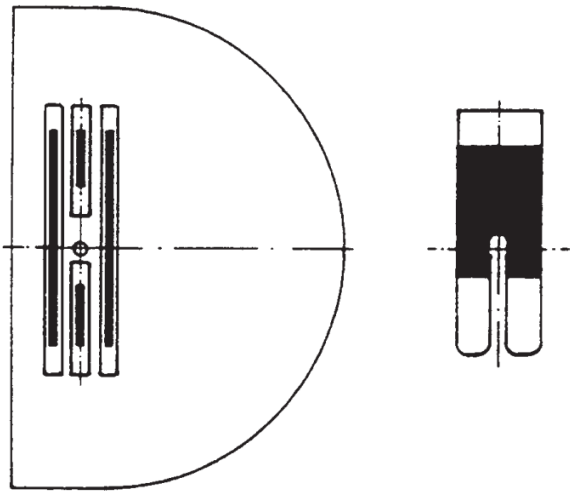

E3

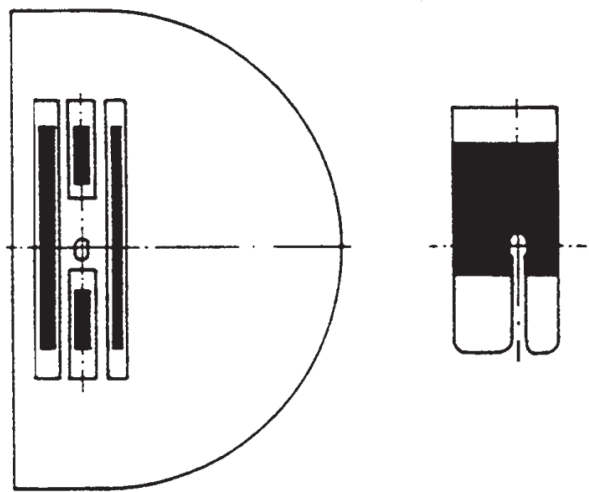

E4

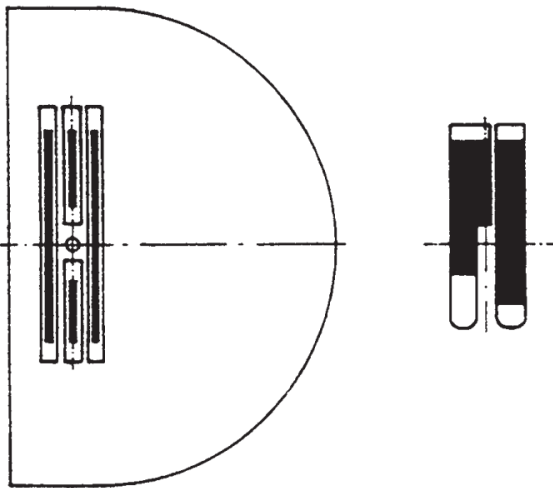

E13

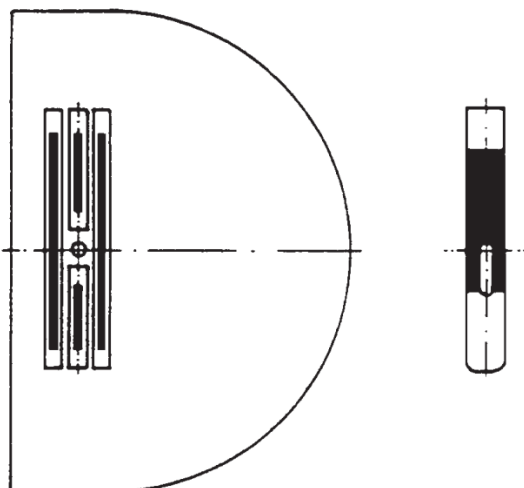

E15

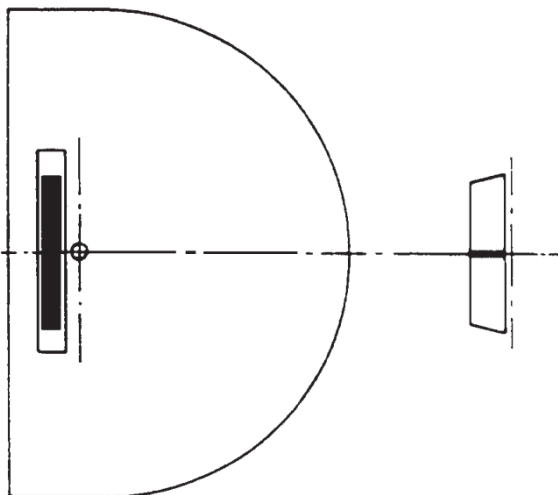

E18

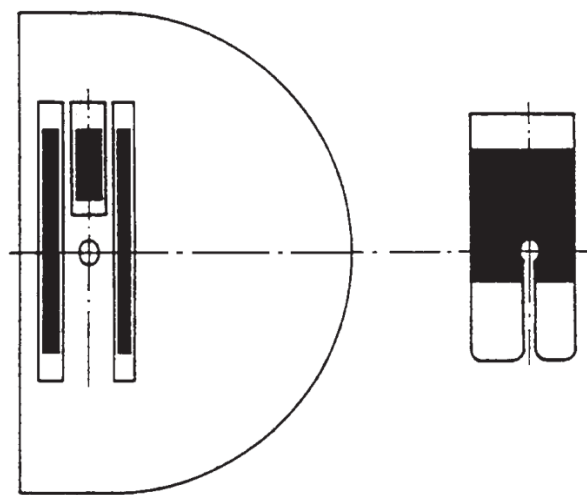

E26

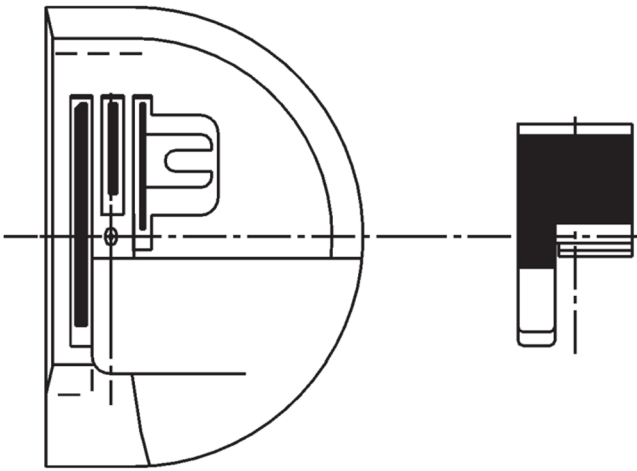

E27

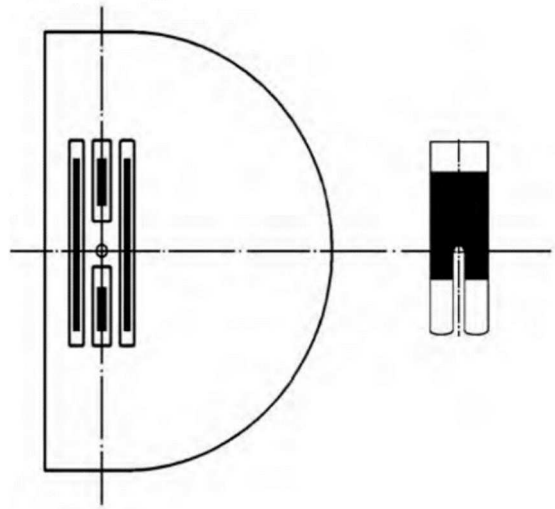

E30

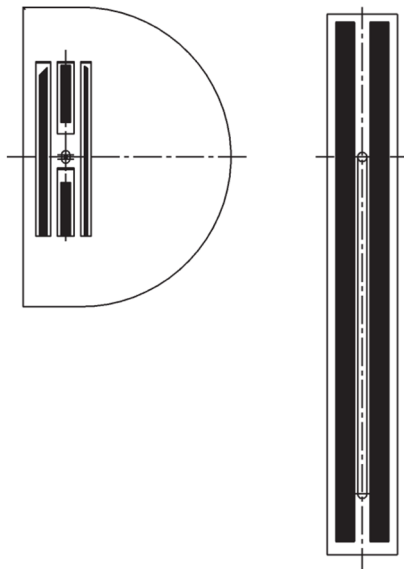

E31

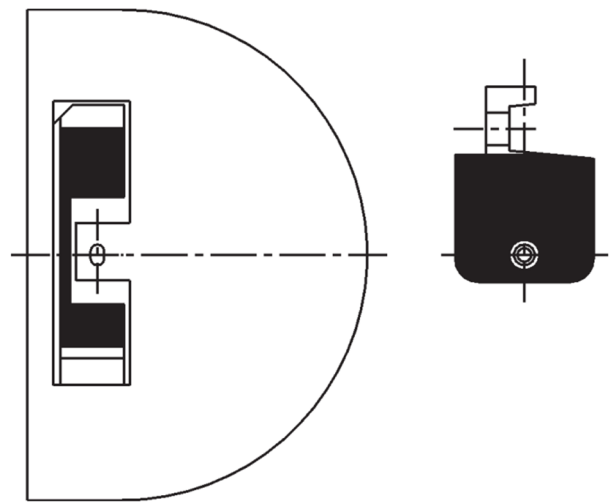

E60

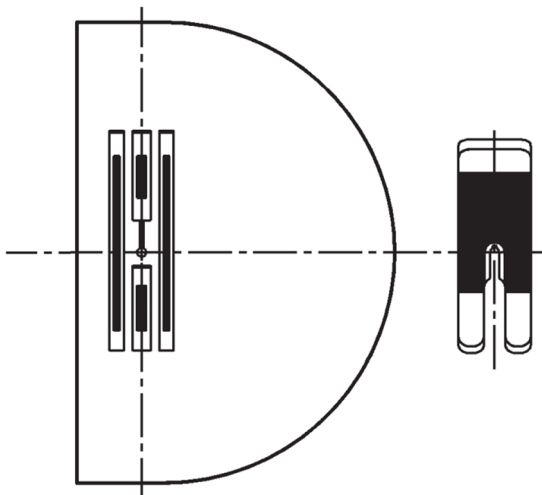

E62

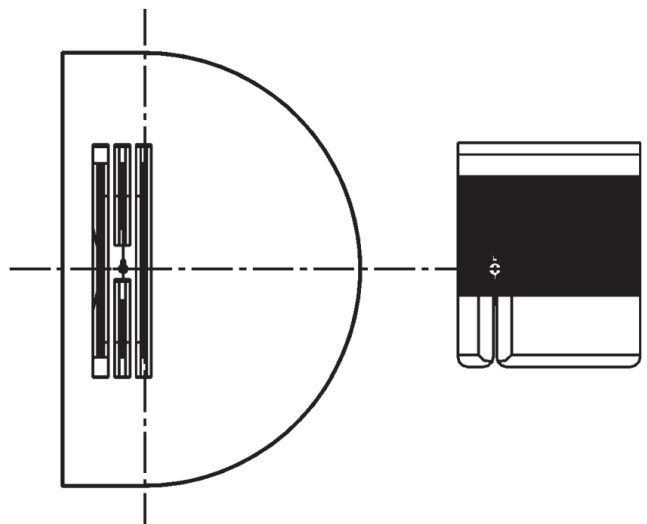

E64

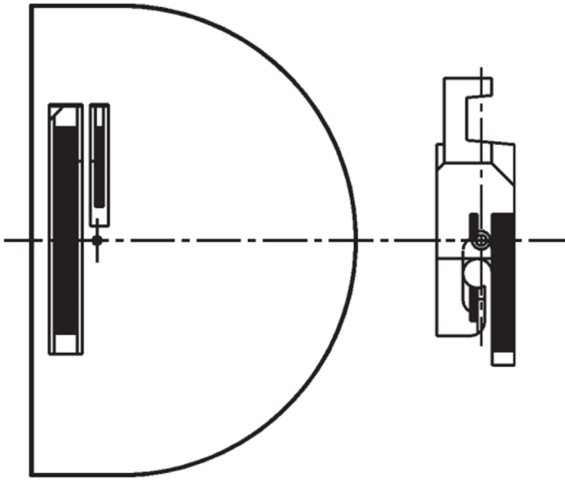

E66

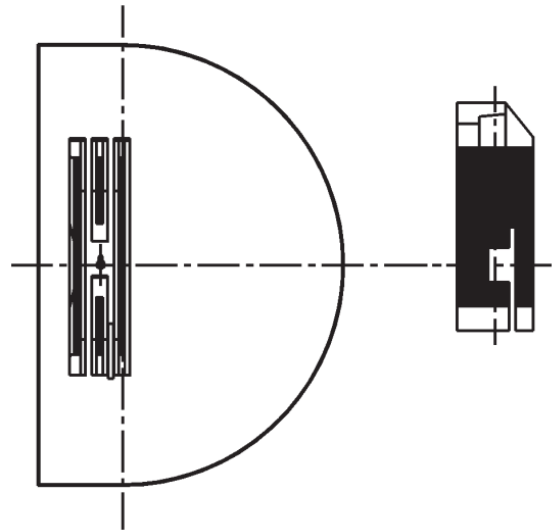

E68

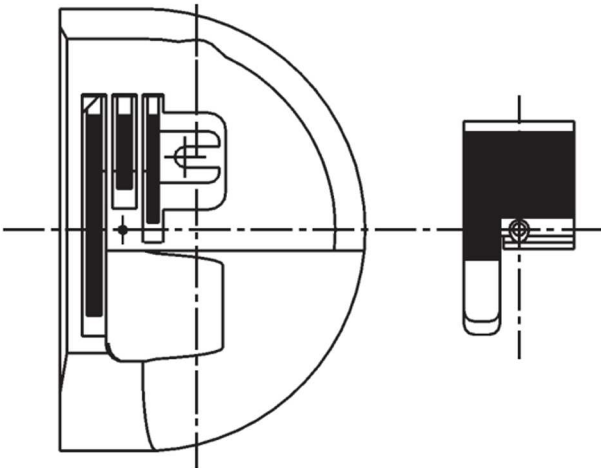



E-Nr. E-No.	Für Unterklassen/For subclasses	Nadelhalter Needle holder				Stichplatte Throat plate		Haupt-Transporteur Main feed dog			Presserfuß Presser foot		Greifer Hook							
		Nadelabstand/ Needle distance [mm]	Nadelhalter/ Needle holder	Nadelhalter, links/ Needle holder, left	Nadelhalter, rechts/ Needle holder, right	Stichlochgröße/ Stitch hole size [mm]	Stichplatte/ Throat plate	Schieber, links/ Slide, left	Schieber, rechts/ Slide, right	Stichlochgröße/ Stitch hole size [mm]	Sägeverzahn/ Serrated [mm]	Säge-schrägverzahn/ Serrated, oblique [mm]	Kreuzverzahn/ Cross toothed [mm]	Dachverzahn/ Roof-shaped [mm]	Fester Fuß/Foot, rigid	Gelenkfuß/Foot, articulated	Hebel-Gelenkfuß/Foot, articulated, with lever	Tandemgelenkfuß	Nadelschutz	Nadelsystem/ Needle system
E5	-140342; -160062; -160362  Allgemeine Näharbeiten im mittelschwerem bis schwerem Nähgut. Max. Stichlänge 6mm  General stitching operations in medium to heavy weight material. Stitch length max. 6mm					3 x 3,9 0272 006513				0272 006610; 2,0					0272 006868					134/ 120
E6	-140342; -160062; -160362  Allgemeine Näharbeiten im mittelschwerem bis schwerem Nähgut. Max. Stichlänge 6mm  General stitching operations in medium to heavy weight material. Stitch length max. 6mm					ø 1,8 0272 006514				0271 006611; 2,0					0272 006868					134/ 100

E-Nr. E-No.	Für Unterklassen/For subclasses	Nadelhalter Needle holder				Stichplatte Throat plate		Haupt-Transporteur Main feed dog			Presserfuß Presser foot			Greifer Hook						
		Nadelabstand/ Needle distance [mm]	Nadelhalter/ Needle holder	Nadelhalter, links/ Needle holder, left	Nadelhalter, rechts/ Needle holder, right	Stichlochgröße/ Stitch hole size [mm]	Stichplatte/ Throat plate	Schieber, links/ Slide, left	Schieber, rechts/ Slide, right	Stichlochgröße/ Stitch hole size [mm]	Sägeverzahn/ Serrated [mm]	Säge-schrägverzahn/ Serrated, oblique [mm]	Kreuzverzahn/ Cross toothed [mm]	Dachverzahn/ Roof-shaped [mm]	Fester Fuß/Foot, rigid	Gelenkfuß/Foot, articulated	Hebel-Gelenkfuß/Foot, articulated, with lever	Ausgleichsgelenkfuß/ Foot articulation comp.	Nadelschutz	Nadelsystem/ Needle system
E20	-140041; -140042; -140341; -140342  Allgemeine Näharbeiten in leichtem bis mittlerem Nähgut. Max. Stichlänge 4mm  General stitching operations light and medium weight material. Stitch length max. 4mm					1,5 x 2,4 0272 006516				0272 006613; 1,6					0272 006873					134/ 80
E27	-140041; -140042; -140341; -140342  Allgemeine Näharbeiten in leichtem Nähgut. Max. Stichlänge 4mm  General stitching operations in light weight material. Stitch length max. 4mm					1,5 x 2,4 0272 006519				0272 006617; 1,2					0272 006801					134/ 80
E29	-140041; -140042; -140341; -140342  Allgemeine Näharbeiten in mittlerem Leder mit Rollfuß ø33mm. Max. Stichlänge 6mm  General stitching operations in medium weight leather with roller foot ø33mm Stitch length max. 6mm					1,8 x 8 0272 006521				0272 006618; 1,2					0272 006896					134LR/ 120

E-Nr. E-No.	Für Unterklassen/For subclasses	Nadelhalter Needle holder				Stichplatte Throat plate		Haupt-Transporteur Main feed dog			Presserfuß Presser foot			Greifer Hook							
		Nadelabstand/ Needle distance [mm]	Nadelhalter/ Needle holder	Nadelhalter, links/ Needle holder, left	Nadelhalter, rechts/ Needle holder, right	Stichlochgröße/ Stitch hole size [mm]	Stichplatte/ Throat plate	Schieber, links/ Slide, left	Schieber, rechts/ Slide, right	Stichlochgröße/ Stitch hole size [mm]	Sägeverzahn/ Serrated [mm]	Säge-schrägverzahn/ Serrated, oblique [mm]	Kreuzverzahn/ Cross toothed [mm]	Dachverzahn/ Roof-shaped [mm]	Fester Fuß/Foot, rigid	Gelenkfuß/Foot, articulated	Hebel-Gelenkfuß/Foot, articulated, with lever	Ausgleichsgelenkfuß/ Foot articulation comp.	Nadelschutz	Nadelsystem/ Needle system	
Abb. Nr. Fig. No.	Verwendungszweck/Use																				
E33	-160362  Allgemeine Näharbeiten und Ziernähte, in Verbindung mit Z116 006741. (Tri-flex-Vorrichtung). Max. Stichtlänge 6mm  General stitching operations and decorative seams, in connection with Z116 006741. (Tri-flex device). Stitch length max. 6mm					1,5 x 2,4 0272 006522				0272 006617; 1,2					0272 068011						134/ 80

E-Nr. E-No.	Für Unterklassen/For subclasses	Nadelhalter Needle holder				Stichplatte Throat plate		Haupt-Transporteur Main feed dog			Presserfuß Presser foot			Greifer Hook						
		Nadelabstand/ Needle distance [mm]	Nadelhalter/ Needle holder	Nadelhalter, links/ Needle holder, left	Nadelhalter, rechts/ Needle holder, right	Stichlochgröße/ Stitch hole size [mm]	Stichplatte/ Throat plate	Schieber, links/ Slide, left	Schieber, rechts/ Slide, right	Stichlochgröße/ Stitch hole size [mm]	Sägeverzahn/ Serrated [mm]	Säge-schrägverzahn/ Serrated, oblique [mm]	Kreuzverzahn/ Cross toothed [mm]	Dachverzahn/ Roof-shaped [mm]	Fester Fuß/Foot, rigid	Gelenkfuß/Foot, articulated	Fußsohle, links/ foot sole, left	Fußsohle, rechts/ foot sole, right	Nadelschutz	Nadelsystem/ Needle system
E40	-140041; -140042; -140341; -140342  Allgemeine Näharbeiten in leichtem Nähgut. Max. Stichtlänge 3mm  General stitching operations in light weight material. Stitch length max. 3mm					1,2 x 2,0 0272 006525				0272 006631; 1,2					0272 006801					134/ 80
E41	-140041; -140042; -140341; -140342  Allgemeine Näharbeiten in mittelschwerem Nähgut; Stichplatte mit Kettelquersteg. Max. Stichtlänge 4mm  General stitching operations in medium weight material; throat plate with whipped cross path. Stitch length max. 4mm					1,5 x 2,4 0272 006525				0272 006632; 1,6					0272 006807					134/ 100

E-Nr. E-No.	Für Unterklassen/For subclasses	Nadelhalter Needle holder				Stichplatte Throat plate		Haupt-Transporteur Main feed dog			Presserfuß Presser foot			Greifer Hook							
		Nadelabstand/Needle distance [mm]	Nadelhalter/Needle holder	Nadelhalter ,links/Needle holder, left	Abdeckplatte/ Covering plate	Stichlochgröße/Stitch hole size [mm]	Stichplatte/Throat plate	Schieber, links/Slide, left	Schieber, rechts/Slide, right	Stichlochgröße/Stitch hole size [mm]	Sägeverzahn/Serrated [mm]	Säge-schrägverzahn/Serrated, oblique [mm]	Kreuzverzahn/Cross toothed [mm]	Dachverzahn/Roof-shaped [mm]	Gelenkfuß/ Foot, articulated	Ausgleichgelenkfuß/ Foot articulation comp.	Fußsohle, links/ foot sole, left	Fußsohle, rechts/ foot sole, right	Nadelschutz/ Needle guard	Nadelsystem/ Needle system	
Abb. Nr. Fig. No.	Verwendungszweck/Use																				
E53	-140041; -140042; -140341; -140342  Verdecktes Aufnähen von Blazertaschen. Kurzer Gelenkfuß. Für mittelschweres Nähgut. Max. Stichlänge 4mm  Concealed attaching of blazer pockets. Short articulated foot. For medium weight material. Stitch length max. 4mm					1,5 x 2,4 0272 006525				0272 006632; 1,6							0272 006817			134/ 100	

E-Nr. E-No.	Für Unterklassen/For subclasses	Nadelhalter Needle holder				Stichplatte Throat plate		Haupt-Transporteur Main feed dog			Presserfuß Presser foot			Greifer Hook						
		Nadelabstand/ Needle distance [mm]	Nadelhalter/ Needle holder	Nadelhalter ,links/ Needle holder, left	Nadelhalter, rechts/ Needle holder, right	Stichlochgröße/ Stitch hole size [mm]	Stichplatte/ Throat plate	Schieber, links/ Slide, left	Schieber, rechts/ Slide, right	Stichlochgröße/ Stitch hole size [mm]	Sägeverzahn/ Serrated [mm]	Säge-schrägverzahn/ Serrated, oblique [mm]	Kreuzverzahn/ Cross toothed [mm]	Dachverzahn/ Roof-shaped [mm]	Fester Fuß/ Foot, rigid	Gelenkfuß/ Foot, articulated	Hebelgelenkfuß/ Foot, articulated, with lever	Ausgleichsgelenkfuß/ Foot, articulation comp.	Nadelschutz/ Needle guard	Nadelsystem/ Needle system
E70	-140342  Allgemeine Näharbeiten in leichtem Nähgut. Max. Stichlänge 3mm  General stitching operations in light weight material. Stitch length 3mm					1,2 x 1,6 0272 006527				0272 006629; 1,2					0272 006801					134 SAN 10 – 70
E75	-140342  Zum einnähen von Ärmeln nach N471. Max. Stichlänge 3mm  For setting sleeves according to N471. Stitch length max. 3mm					1,2 x 1,6 0272 006527				0272 006630; 1,2					0272 068058					134 SAN 10 – 70
E101	-640142; -640642; -740142; -740642  Für mittelschweres Nähgut, Messer vor und neben der Nadel schneidend. Schneidabstand 3,5mm. Max. Stichlänge 4mm  For sewing in medium weight material, knife beside and in front of the needle. Cutting margin 3,5mm Stitch length max. 4mm					1,5 x 2,4 0272 006531				0272 006621; 1,6					0272 068031			0272 007043		134/ 80

E-Nr. E-No.	Für Unterklassen/For subclasses	Nadelhalter Needle holder				Stichplatte Throat plate			Haupt-Transporteur Main feed dog			Presserfuß Presser foot			Greifer Hook						
		Nadelabstand/ Needle distance [mm]	Nadelhalter/ Needle holder	Nadelhalter ,links/Needle holder, left	Nadelhalter, rechts/ Needle holder, right	Stichlochgröße/ Stitch hole size [mm]	Stichplatte/ Throat plate	Schieber, links/ Slide, left	Schieber, rechts/ Slide, right	Stichlochgröße/ Stitch hole size [mm]	Sägeverzahn/ Serrated [mm]	Säge-schrägverzahn/ Serrated, oblique [mm]	Kreuzverzahn/ Cross toothed [mm]	Dachverzahn/ Roof-shaped [mm]	Fester Fuß/ Foot, rigid	Gelenkfuß/ Foot, articulated	Hebelgelenkfuß/ Foot, articulated, with lever	Ausgleichsgelenkfuß/ Foot, articulation comp.	Einlage/ Layer	Messer Schneidabstand/ Knife cutting margin	Nadelsystem/ Needle system
E102	-640142; -640642; -740142; -740642  Wie E101, jedoch Schneidabstand 5mm. Same as E101, but cutting margin 5mm.					1,5 x 2,4 0272 006535				0272 006622; 1,6					0272 068034				0272 007043	5,0	134/ 80
E103	-640142; -640642; -740142; -740642  Wie E101, jedoch Schneidabstand 8mm. Same as E101, but cutting margin 8mm.					1,5 x 2,4 0272 006537				0272 006623; 1,2					0272 068036				0272 007044	8,0	134/ 80
E107	-740642  Näheinrichtung für Montagenähte mit Führungsnase im Fuß, 2mm links der Nadel. Für Kragen/ Manschetten. Schneidabstand 5mm Max. Stichlänge 4mm  Sewing equipment for sewing assemblage with guide lug at the foot, 2mm on the needle. For collars/ cuffs. Cutting margin 5mm Stitch length 4mm					1,2 x 2,0 0272 006535				0272 006633; 1,2					0272 068024				0272 007043	5,0	134 SAN 10 - 70

E-Nr. E-No.	Für Unterklassen/For subclasses	Nadelhalter Needle holder				Stichplatte Throat plate			Haupt-Transporteur Main feed dog			Presserfuß Presser foot			Greifer Hook						
		Nadelabstand/ Needle distance [mm]	Nadelhalter/ Needle holder	Nadelhalter ,links/Needle holder, left	Nadelhalter, rechts/ Needle holder, right	Stichlochgröße/ Stitch hole size [mm]	Stichplatte/ Throat plate	Schieber, links/ Slide, left	Schieber, rechts/ Slide, right	Stichlochgröße/ Stitch hole size [mm]	Sägeverzahn/ Serrated [mm]	Säge-schrägverzahn/ Serrated, oblique [mm]	Kreuzverzahn/ Cross toothed [mm]	Dachverzahn/ Roof-shaped [mm]	Fester Fuß/ Foot, rigid	Gelenkfuß/ Foot, articulated	Hebelgelenkfuß/ Foot, articulated, with lever	Ausgleichsgelenkfuß/ Foot, articulation comp.	Einlage/ Layer	Messer Schneidabstand/ Knife cutting margin	Nadelsystem/ Needle system
E111	-140041; -140042; -140341; -140342  Näheinrichtung für gestuftes Beschneiden in leichtem Nähgut; in Verbindung mit Z145 000101 einzusetzen. Schneidabstand 4,5 und 7mm Max. Stichlänge 4mm  Sewing equipment for stepped trimming light weight material; to be used in conjunction with Z145 000101. Cutting margin 4,5 and 7mm. Stitch length max. 4mm.					1,5 x 2,4 0272 006541				0272 006624; 1,6					0272 068043			0272 007043		134 KK/ 80	



E-Nr. E-No.	Für Unterklassen/For subclasses	Nadelhalter Needle holder				Stichplatte Throat plate			Haupt-Transporteur Main feed dog			Presserfuß Presser foot			Greifer Hook					
		Nadelabstand/ Needle distance [mm]	Nadelhalter/ Needle holder	Nadelhalter ,links/Needle holder, left	Abdeckplatte/ Covering plate	Stichlochgröße/ Stitch hole size [mm]	Stichplatte/ Throat plate	Schieber, links/ Slide, left	Schieber, rechts/ Slide, right	Stichlochgröße/ Stitch hole size [mm]	Sägeverzahn/ Serrated [mm]	Säge-schrägverzahn/ Serrated, oblique [mm]	Kreuzverzahn/ Cross toothed [mm]	Dachverzahn/ Roof-shaped [mm]	Fester Fuss/ Foot, rigid	Gelenkfuss/ Foot, articulated	Hebelgelenkfuss/ Foot, articulated, with lever	Ausgleichsgelenkfuss/ Foot, articulation comp.	Einlage/ Layer	Nadelsystem/ Needle system
Abb. Nr. Fig. No.	Verwendungszweck/Use																			
E113	-740142; -70642  Allgemeine Näharbeiten in mittelschwerem Nähgut. Näheinrichtung für Kleinteilfertigung mit Klappschablonen. Zum Nähen und Beschneiden von Kleinteilen wie Patten, Ärmelspangen, Schulterklappen, Bundverlängerungen usw. Nähen von Spitzfasson auf Anfrage. Schneidabstand 3,5mm Max. Stichlänge 4mm  General stitching operations in medium weight material. Sewing equipment for the manufacture of small parts with templates. For sewing and trimming of small parts like flaps, sleeve clasps, shoulder tabs, waistband extensions and the like. Sewing of peak label on request. Cutting margin max. 3,5mm Stitch length max. 4mm			0272 007046	1,5 x 2,4	0272 006549			0272 006627; 1,6				0272 068053				0272 007043			134 KK/ 80

E-Nr. E-No.	Für Unterklassen/For subclasses	Nadelhalter Needle holder				Stichplatte Throat plate			Haupt-Transporteur Main feed dog			Presserfuß Presser foot			Greifer Hook					
		Nadelabstand/ Needle distance [mm]	Nadelhalter/ Needle holder	Nadelhalter ,links/Needle holder, left	Abdeckplatte/ Covering plate	Stichlochgröße/ Stitch hole size [mm]	Stichplatte/ Throat plate	Schieber, links/ Slide, left	Schieber, rechts/ Slide, right	Stichlochgröße/ Stitch hole size [mm]	Sägeverzahn/ Serrated [mm]	Säge-schrägverzahn/ Serrated, oblique [mm]	Kreuzverzahn/ Cross toothed [mm]	Dachverzahn/ Roof-shaped [mm]	Fester Fuss/ Foot, rigid	Gelenkfuss/ Foot, articulated	Hebelgelenkfuss/ Foot, articulated, with lever	Ausgleichsgelenkfuss/ Foot, articulation comp.	Einlage/ Layer	Nadelsystem/ Needle system
Abb. Nr. Fig. No.	Verwendungszweck/Use																			
E114	-740142; -70642  Allgemeine Näharbeiten in mittelschwerem Nähgut. Näheinrichtung zum Nähen von Spitzfasson mit Klappschablonen. Schneidabstand 3,5mm Max. Stichtlänge 4mm  General stitching operations in medium weight material. Sewing equipment for peak label with templates. Cutting margin 3,5mm Stitch length max. 4mm				0272 007046	1,5 x 2,4	0272 006549				0272 006627; 1,6			0272 068056				0272 007043		134 KK/ 80
E115	-740642; -640642  Näheinrichtung zum Beschneiden der Stoffkanten. Für mittelschweres Nähgut, Messer vor und neben der Nadel schneidend. Schnittabstand 4mm Max. Stichtlänge 4mm  Sewing equipment for trimming the fabric edges. For sewing in medium weight material, knife beside and in front of the needle. Cutting margin 4mm Stitch length max. 4mm				0272 007046	1,5 x 2,4	0271 200063				0272 006621			0272 068031				0272 007043		134 KK/ 80

E5

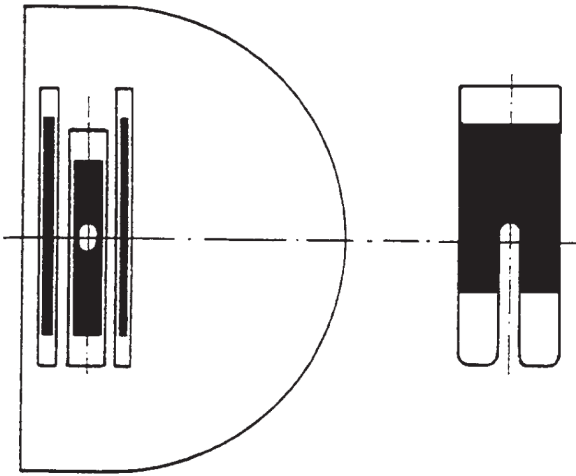

E6

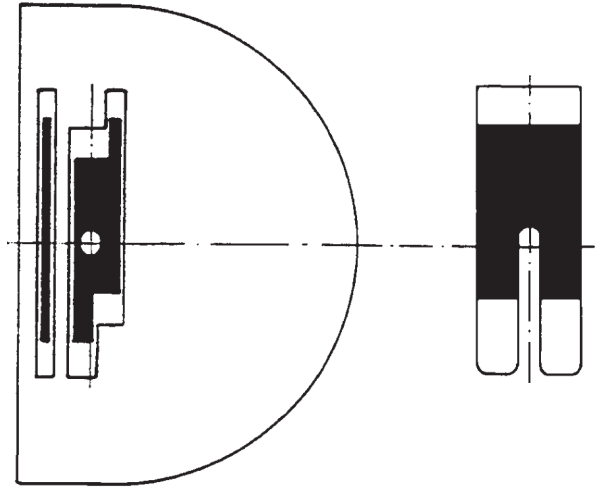

E20

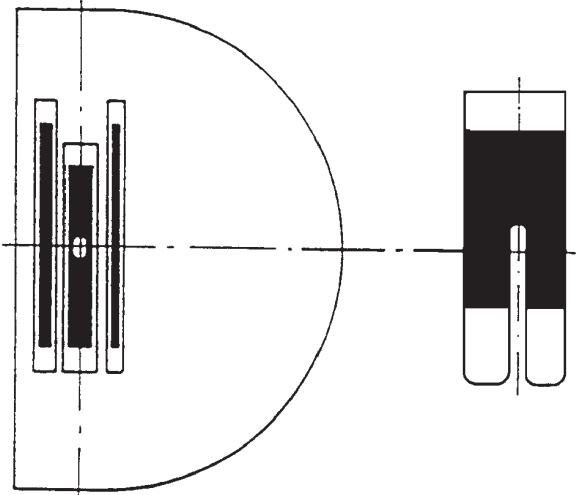

E27

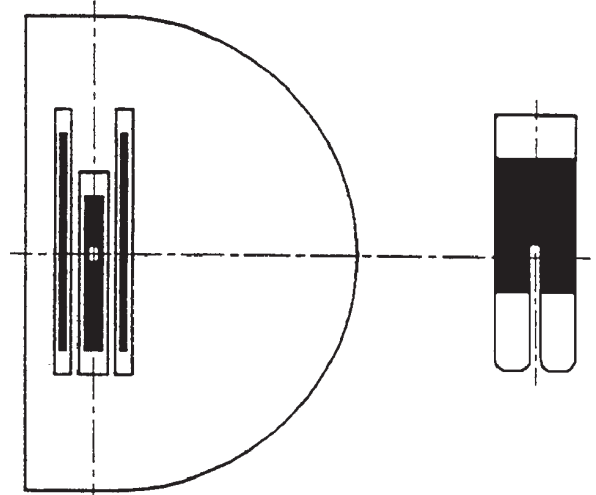

E29

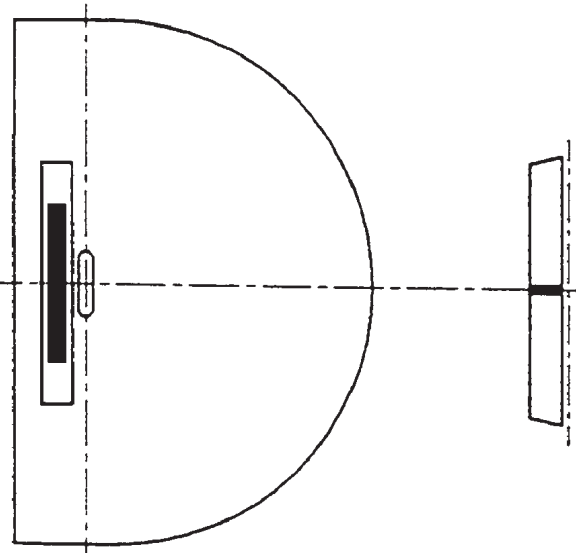

E33

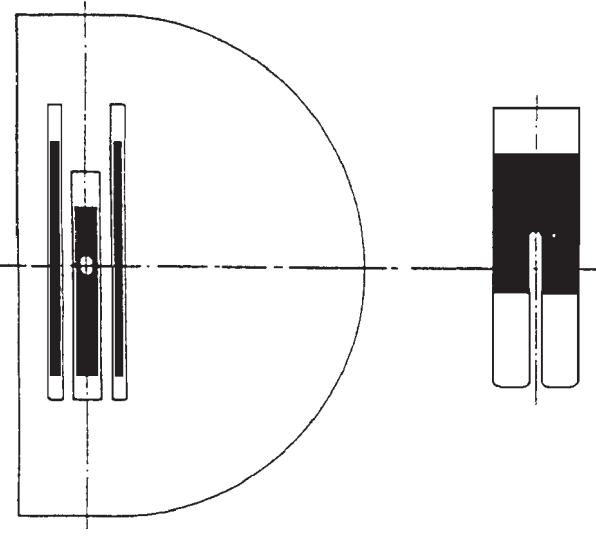

E40

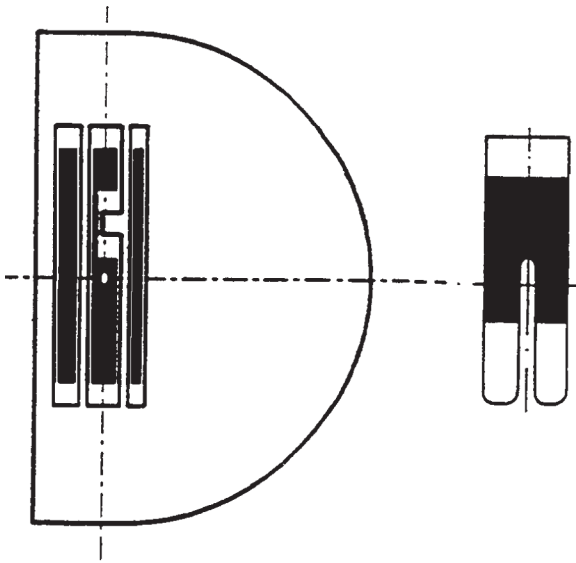

E41

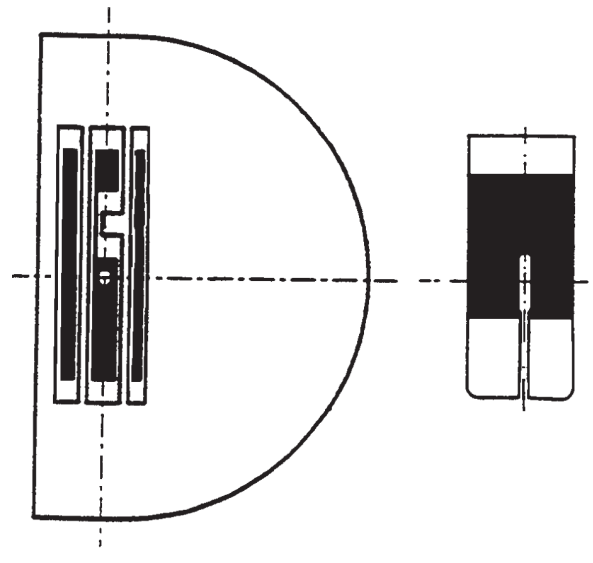

E53

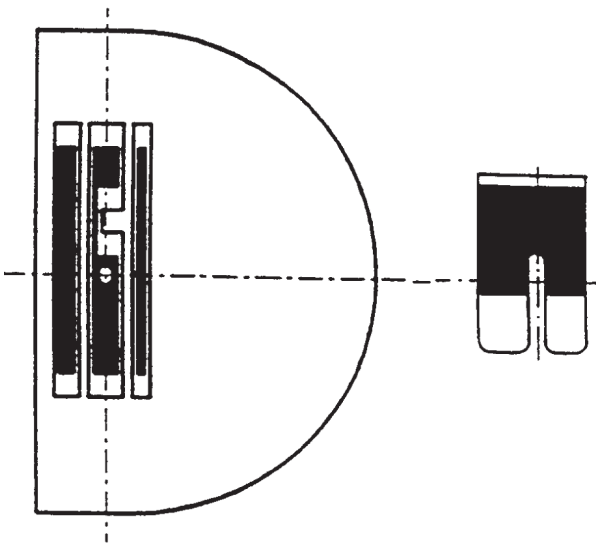

E70

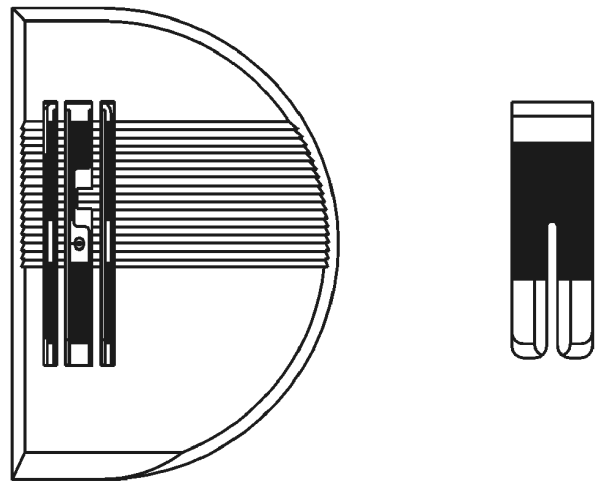

E75

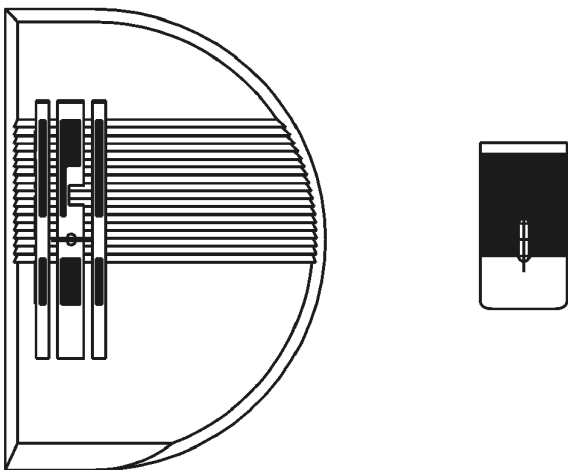

E101

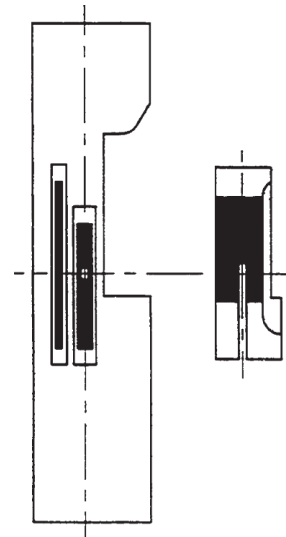

E102

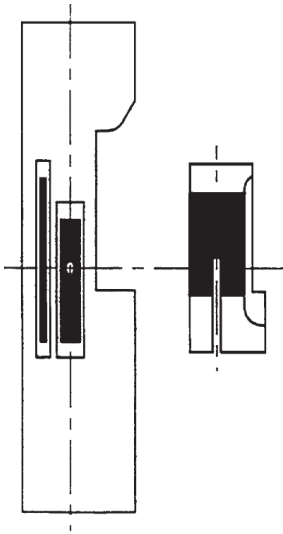

E103

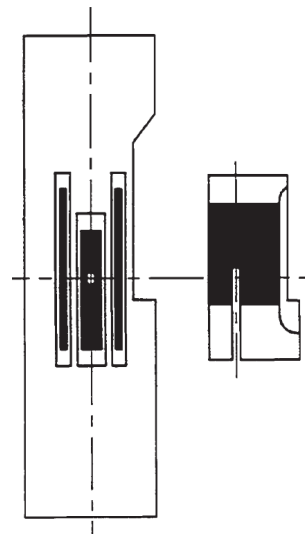

E107

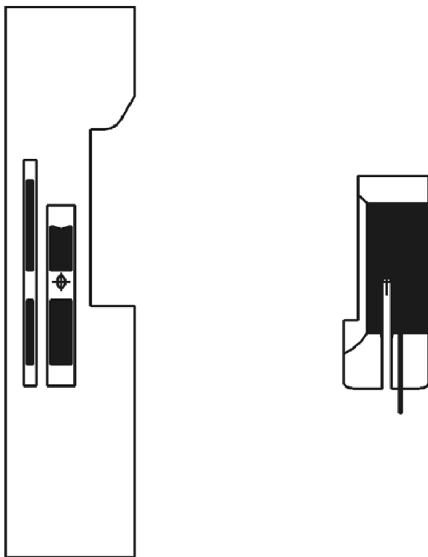

E111

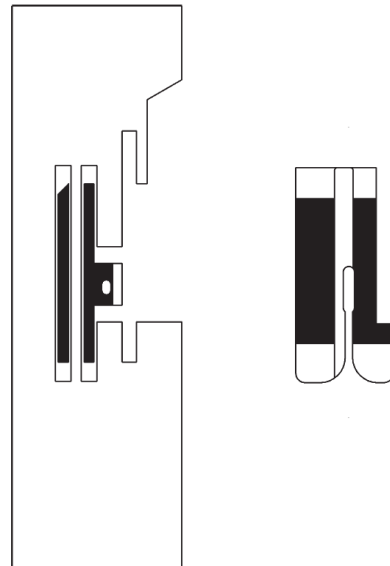

E113

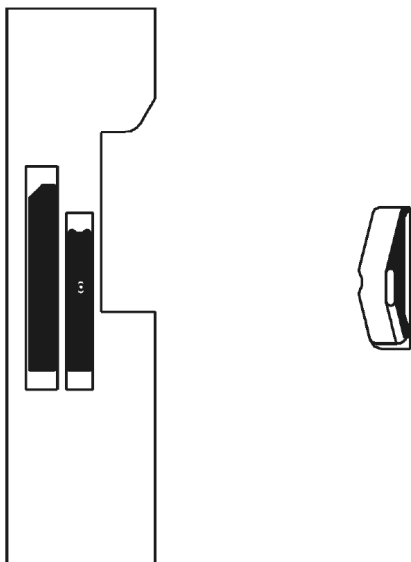

E114

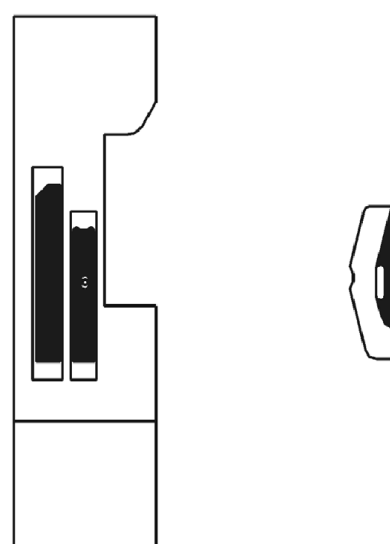

E115

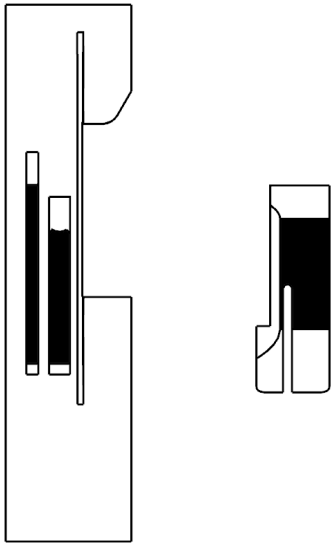

E-Nr. E-No.	Für Unterklassen/ For subclasses	Nadelhalter Needle holder				Stichplatte Throat plate			Haupt-Transporteur Main feed dog			Presserfuß Presser foot			Greifer Hook						
		Nadelabstand/ Needle distance [mm]	Nadelhalter/ Needle holder	Nadelhalter, links/ Needle holder, left	Nadelhalter, rechts/ Needle holder, right	Stichlochgröße/ Stitch hole size [mm]	Stichplatte/ Throat plate	Schieber, links/ Slide, left	Schieber, rechts/ Slide, right	Stichlochgröße/ Stitch hole size [mm]	Sägeverzahn/ Serrated [mm]	Säge-schrägverzahn/ Serrated, oblique [mm]	Kreuzverzahn/ Cross toothed [mm]	Dachverzahn/ Roof-shaped [mm]	Säumerfuß/ Foot, hemming	Gelenkfuß/ Foot, articulated	Transportfuß/ Foot, Feeding	Tandemgelenkfuß/ Foot, hinged tandem	Kantenanschlag/ edge guide	Kloben, kpl./ block, complete	Nadelsystem/ Needle system
E2	-140042; -140342  Allgemeine Näharbeiten in leichtem Nähgut. Max. Stichlänge 4mm  General stitching operations in light weight material. Stitch length max. 4mm					ø 1,5 0211 004521				0271 006602; 1,6					0273 006801						134/ 80
E3	-140042; -140342  Allgemeine Näharbeiten in mittelschwerem Nähgut. Max. Stichlänge 4mm  General stitching operations in medium weight material. Stitch length max. 4mm					ø 1,5 0211 001491				0271 006603; 2,0					0273 006808						134/ 100
E9	-140042; -140342  Näheinrichtung zum Kantensteppen mit Anschlag 1,6mm links der Nadel in sehr leichtem und leichtem Nähgut. Ausgleichsgelenkfuß, gefedert. Max. Stichlänge 4mm  Sewing equipment for stitching on edges, stop 1,6mm on the left of the needle. For very light and light weight material. With spring-loaded articulated compensating foot. Stitch length max. 4mm					ø 1,8 0273 006504				0273 006604; 1,2					0274 006834						134/ 80

E-Nr. E-No.	Für Unterklassen/ For subclasses	Nadelhalter Needle holder				Stichplatte Throat plate			Haupt-Transporteur Main feed dog			Presserfuß Presser foot			Greifer Hook							
		Nadelabstand/ Needle distance [mm]	Nadelhalter/ Needle holder	Nadelhalter, links/ Needle holder, left	Nadelhalter, rechts/ Needle holder, right	Stichlochgröße/ Stitch hole size [mm]	Stichplatte/ Throat plate	Schieber, links/ Slide, left	Schieber, rechts/ Slide, right	Stichlochgröße/ Stitch hole size [mm]	Sägeverzahn/ Serrated [mm]	Säge-schrägverzahn/ Serrated, oblique [mm]	Kreuzverzahn/ Cross toothed [mm]	Dachverzahn/ Roof-shaped [mm]	Säumerfuß/ Foot, hemming	Gelenkfuß/ Foot, articulated	Transportfuß/ Foot, Feeding	Tandemgelenkfuß/ Foot, hinged tandem	Kantenanschlag/ edge guide	Kloben, kpl./ block, complete	Nadelsystem/ Needle system	
E11	-140042																					
	<p>Für Säume nach NB1 und NB5 mit Vorsatzsäumen in sehr leichtem und leichtem Nähgut. Sohlenbreite ist auf Saumbreite abzustimmen. Max. Stichlänge 4mm</p> <p>For hemming according to NB1 and NB5. Hemmer in front of the presser foot. For very light and light weight material. Sole width must be adapted to the hem width. Stich length max. 4mm</p>				ø 1,5	0211 004521				0271 006602; 1,6						0273 006845					134/ 80	



E-Nr. E-No.	Für Unterklassen/ For subclasses	Nadelhalter Needle holder				Stichplatte Throat plate			Haupt-Transporteur Main feed dog			Presserfuß Presser foot			Greifer Hook						
		Nadelabstand/ Needle distance [mm]	Nadelhalter/ Needle holder	Nadelhalter, links/ Needle holder, left	Nadelhalter, rechts/ Needle holder, right	Stichlochgröße/ Stitch hole size [mm]	Stichplatte/ Throat plate	Schieber, links/ Slide, left	Schieber, rechts/ Slide, right	Stichlochgröße/ Stitch hole size [mm]	Sägeverzahn/ Serrated [mm]	Säge-schrägverzahn/ Serrated, oblique [mm]	Kreuzverzahn/ Cross toothed [mm]	Dachverzahn/ Roof-shaped [mm]	Säumerfuß/ Foot, hemming	Gelenkfuß/ Foot, articulated	Transportfuß/ Foot, Feeding	-	Kantenanschlag/ edge guide	Kloben, kpl./ block, complete	Nadelsystem/ Needle system
Abb. Nr. Fig. No.	Verwendungszweck/ Use																				
E24	-140042; -140342  Allgemeine Näharbeiten in sehr leichtem Nähgut. Max. Stichlänge 3mm  General stitching operations in very light weight material. Stitch length max. 3mm					ø 1,8	0273 006504			0273 006604; 1,2					0273 006847						134/ 80
E30	-140432  Allgemeine Näharbeiten in leichtem Nähgut. Max. Stichlänge 4mm  General stitching operations in light weight material. Stitch length max. 4mm					ø 1,5	0275 200130			0275 210090					0273 006825						134 SAN 10 – 70
E32	-140042  Für Säume nach NB1 und NB5 mit Vorsatzsäumer. Für sehr leichtes bis sehr leichtes Nähgut. Sohlenbreite ist auf Saumbreite abzustimmen. Max. Stichlänge 4mm  For hemming according to NB1 to NB5. Hemmer in front of the presser foot. For very light and light weight material. Sole width must be adapted to the hem width. Stitch length max. 4mm					ø 1,5	0275 200130			0275 210090					0273 006827						134 SAN 10 – 70

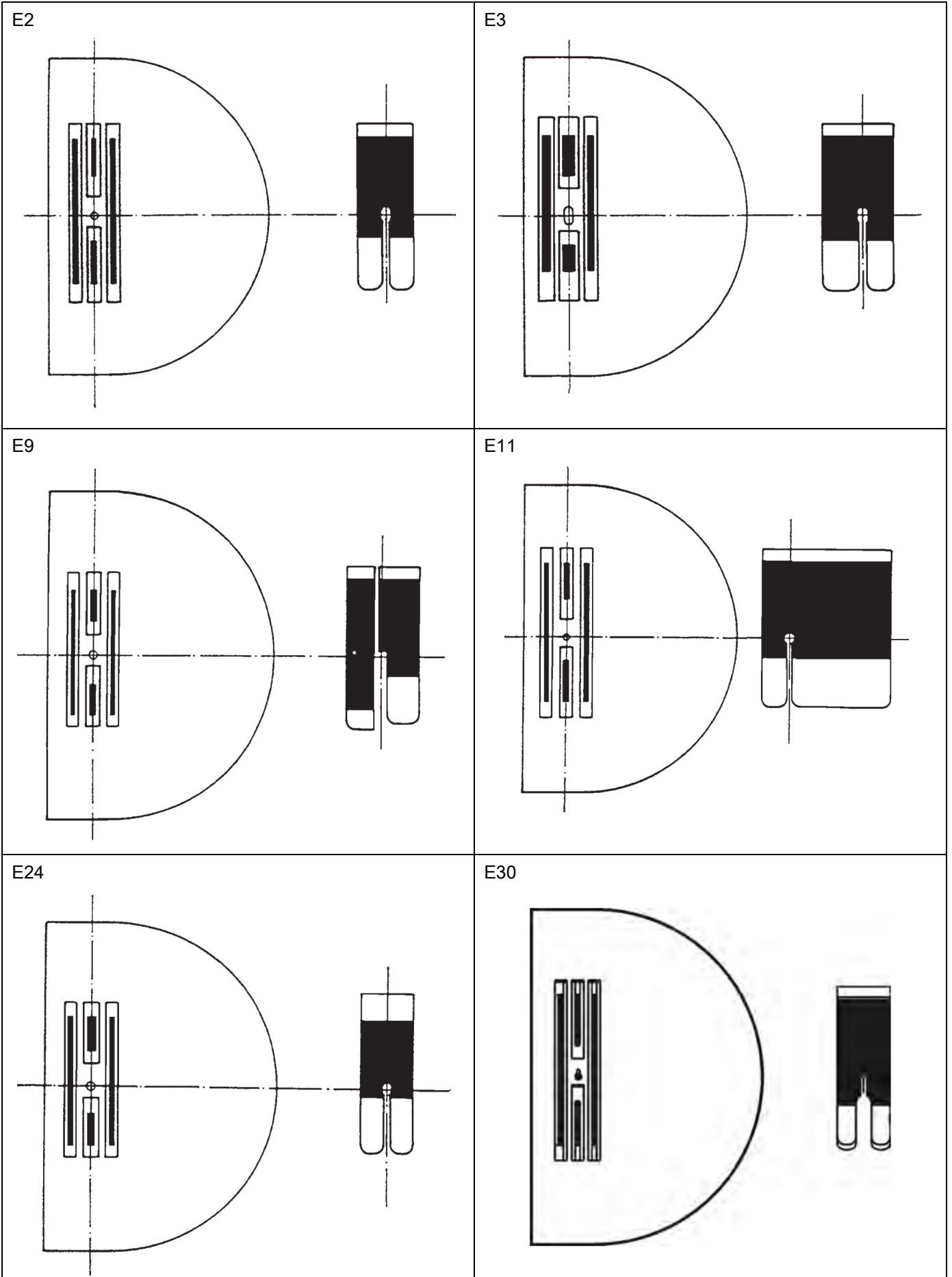

E32

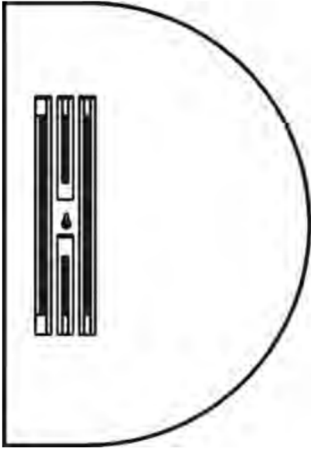



E-Nr. E-No.	Für Unterklassen/ For subclasses	Nadelhalter Needle holder				Stichplatte Throat plate			Haupt-Transporteur Main feed dog			Presserfuß Presser foot			Greifer Hook						
		Nadelabstand/ Needle distance [mm]	Nadelhalter/ Needle holder	Nadelhalter, links/ Needle holder, left	Nadelhalter, rechts/ Needle holder, right	Stichlochgröße/ Stitch hole size [mm]	Stichplatte/ Throat plate	Schieber, links/ Slide, left	Schieber, rechts/ Slide, right	Stichlochgröße/ Stitch hole size [mm]	Sägeverzahn/ Serrated [mm]	Säge-schrägverzahn/ Serrated, oblique [mm]	Kreuzverzahn/ Cross toothed [mm]	Dachverzahn/ Roof-shaped [mm]	Säumerfuß/ Foot, hemming	Gelenkfuß/Foot, articulated	Transportfuß/ Foot, Feeding	Tandemgelenkfuß/ Foot, hinged tandem	Kantenanschlag/ edge guide	Kloben, kpl./ block, complete	Nadelsystem/ Needle system
E40	-140042; -140342  Allgemeine Näharbeiten in leichtem Nähgut. Ersetzt Näheinrichtung E38. Max. Stichlänge 3mm  General stitching operations in light weight material. Replace the equipment of E38. Stitching length max. 3mm														0274 006851						134/ 80
E41	-140042; -140342  Allgemeine Näharbeiten in leichtem bis mittelschwerem Nähgut. Ersetzt Näheinrichtung E3 und E4. Max. Stichlänge 3mm  General stitching operations in light and medium weight material. Replaced the equipment of E3 and E4. Stich length max. 3mm					1,5 x 2,4 0272 006525				0272 006632; 1,6					0274 006801						134/ 100

E5

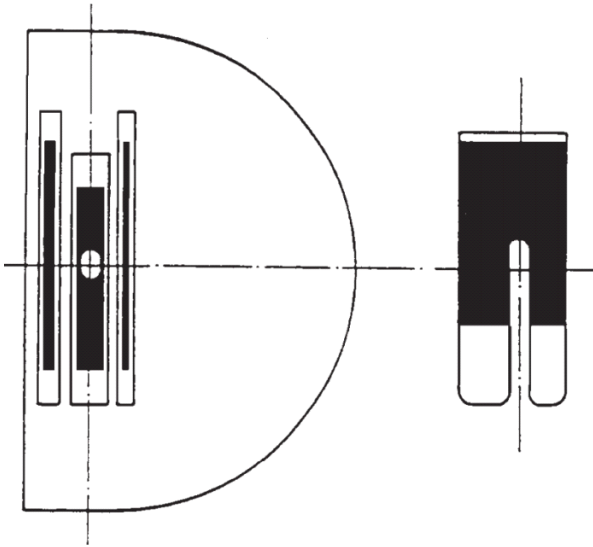

E15

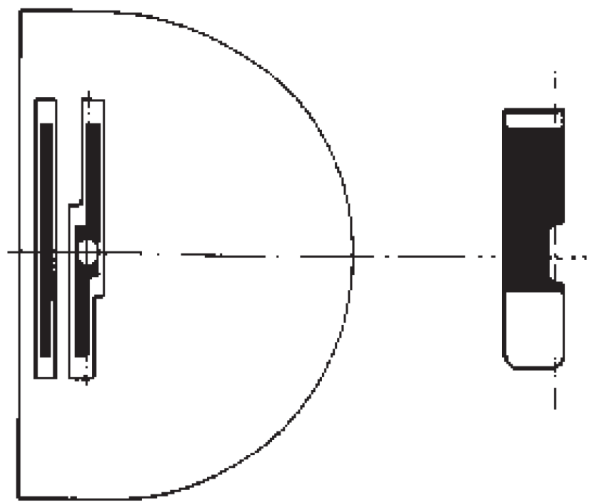

E27

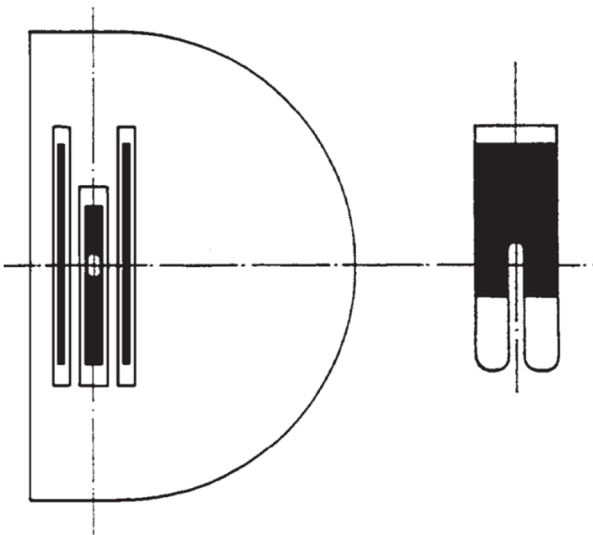

E40

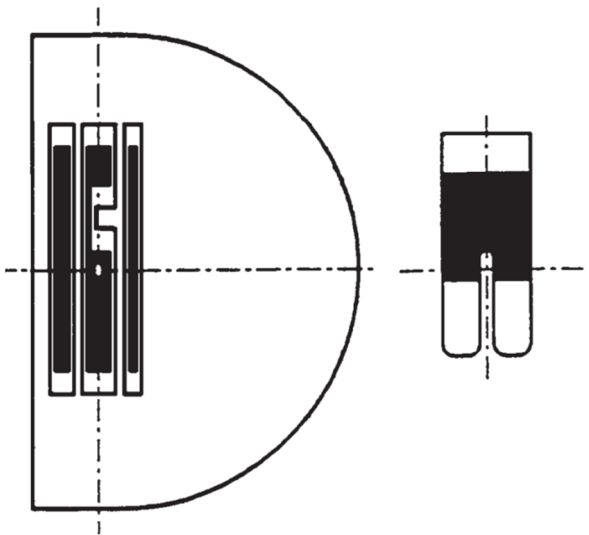

E41

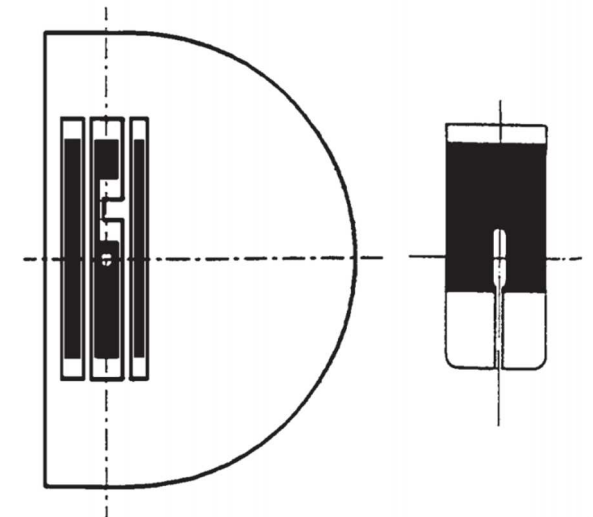

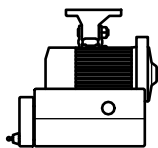

Quick  
QE3760/DA40MS  
9800 351006 DAT

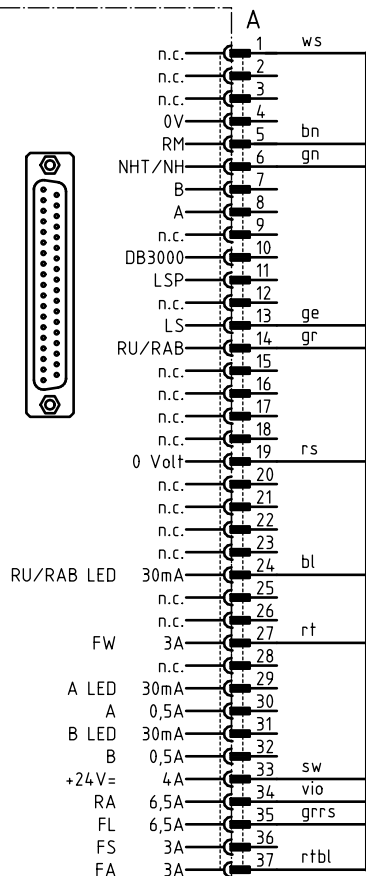
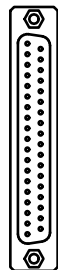

9870 271004

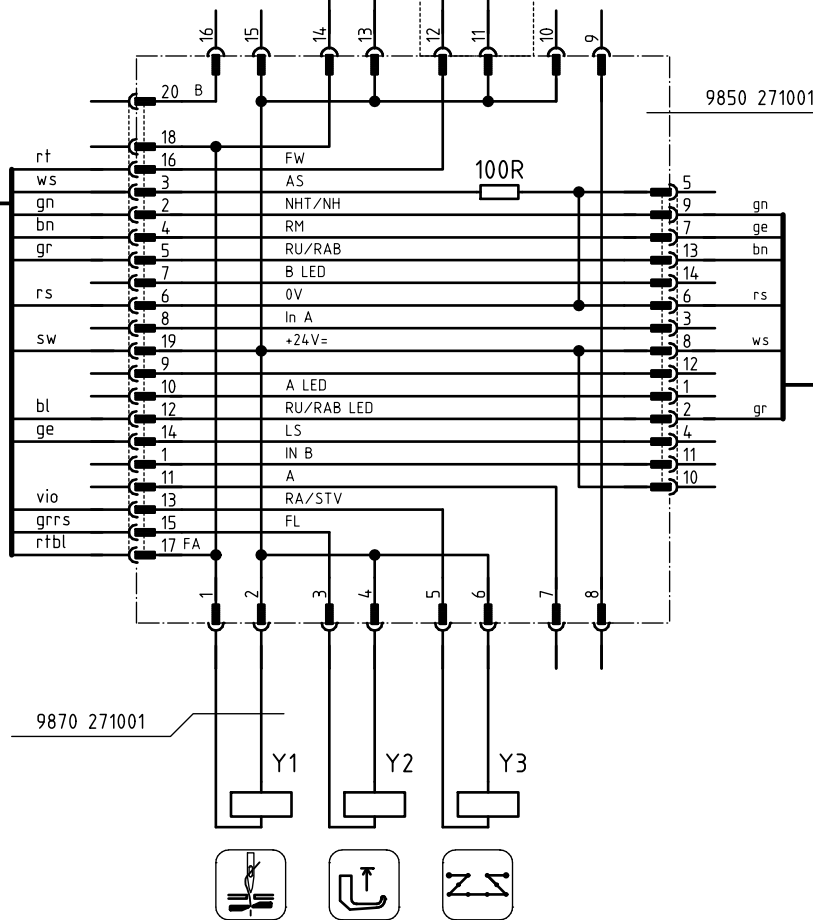

9870 271001

9850 271001

271-140342  
271-140442  
272-140342  
272-160362

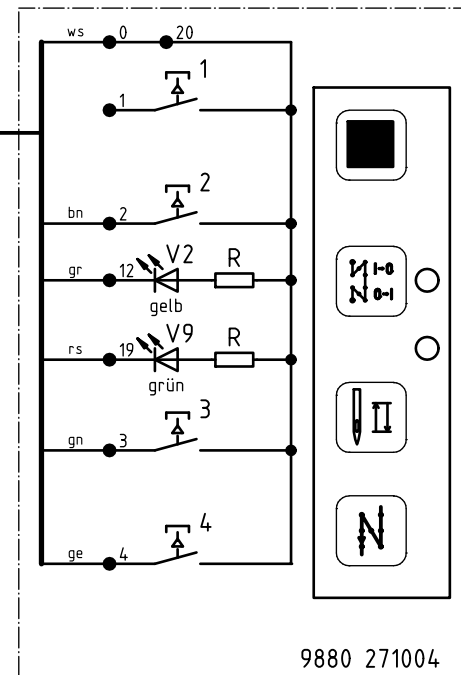
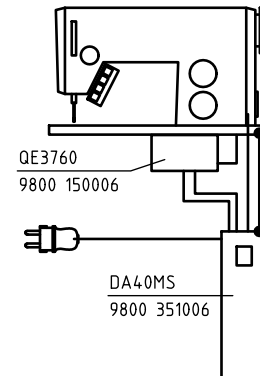

9880 271004

= auf Wunsch/on request

c			Datum	05.03.98
b			Bearb.	RE
a	02.0	16.10.98	RE	Gepr.
	Änderung	Datum	Name	Norm



Teilfamilie  
Freigabe  
1059 / 98

271-140342, 272-140342  
mit Nähtrieb 9800 150006 R  
with sewing motor 9800 150006 R

Bauschaltplan  
9890 271001 B

Blatt  
1/2

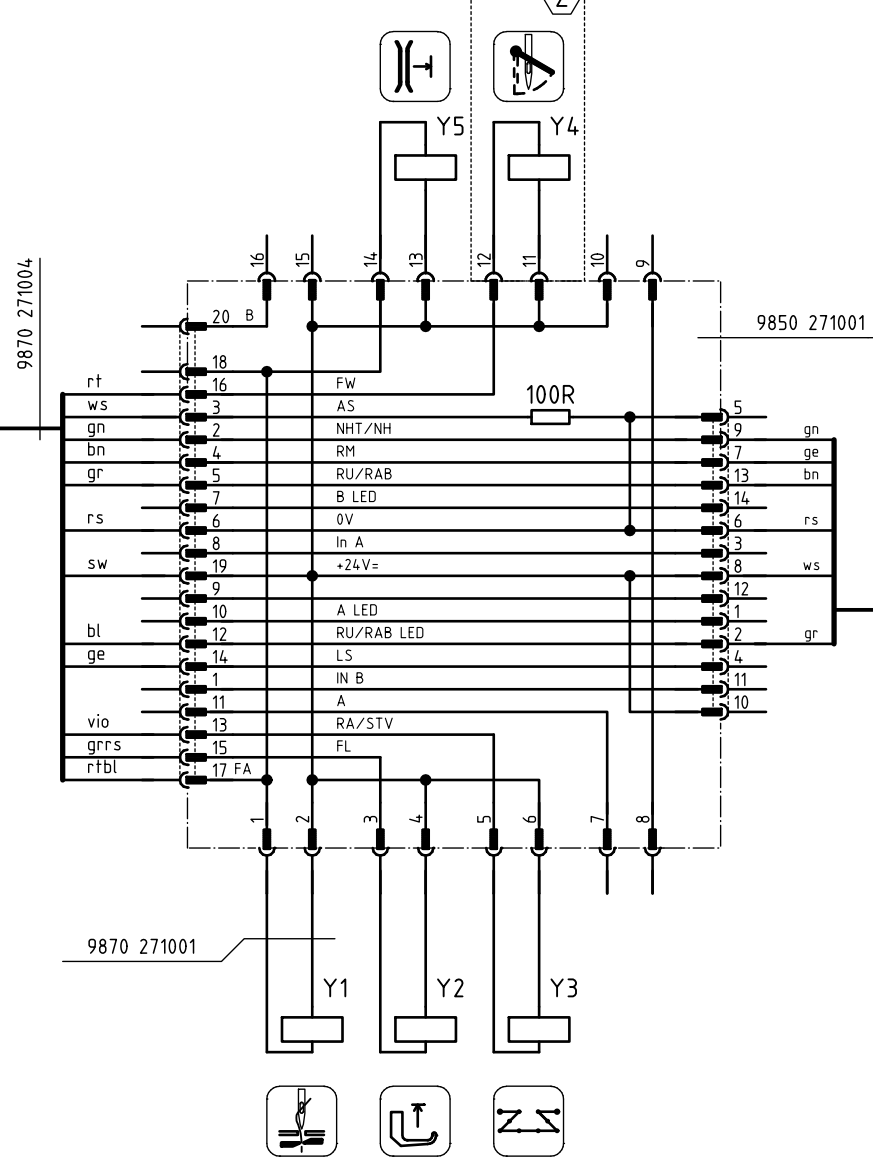
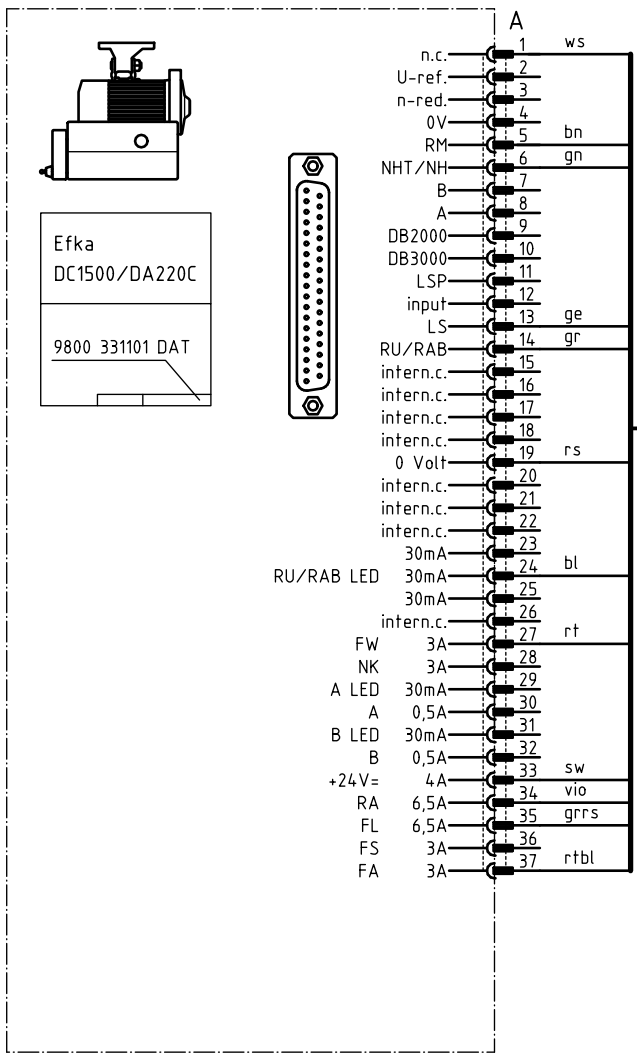

271-140342  
 271-140442  
 272-140342  
 272-160362

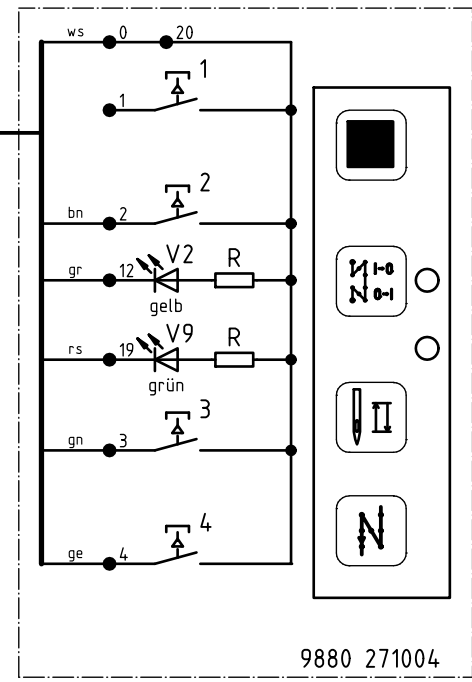
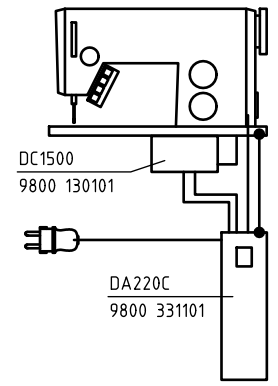

= auf Wunsch/on request



c			Datum	05.03.98
b			Bearb.	RE
a	02.0	16.10.98	RE	Gepr.
	Änderung	Datum	Name	Norm



Teilfamilie  
 Freigabe  
 1059 / 98

271-140342, 272-140342  
 mit Näh Antrieb 9800 130101 R  
 with sewing motor 9800 130101 R

Bauschaltplan  
 9890 271001 B

Blatt  
 2 / 2



(Auf Wunsch)

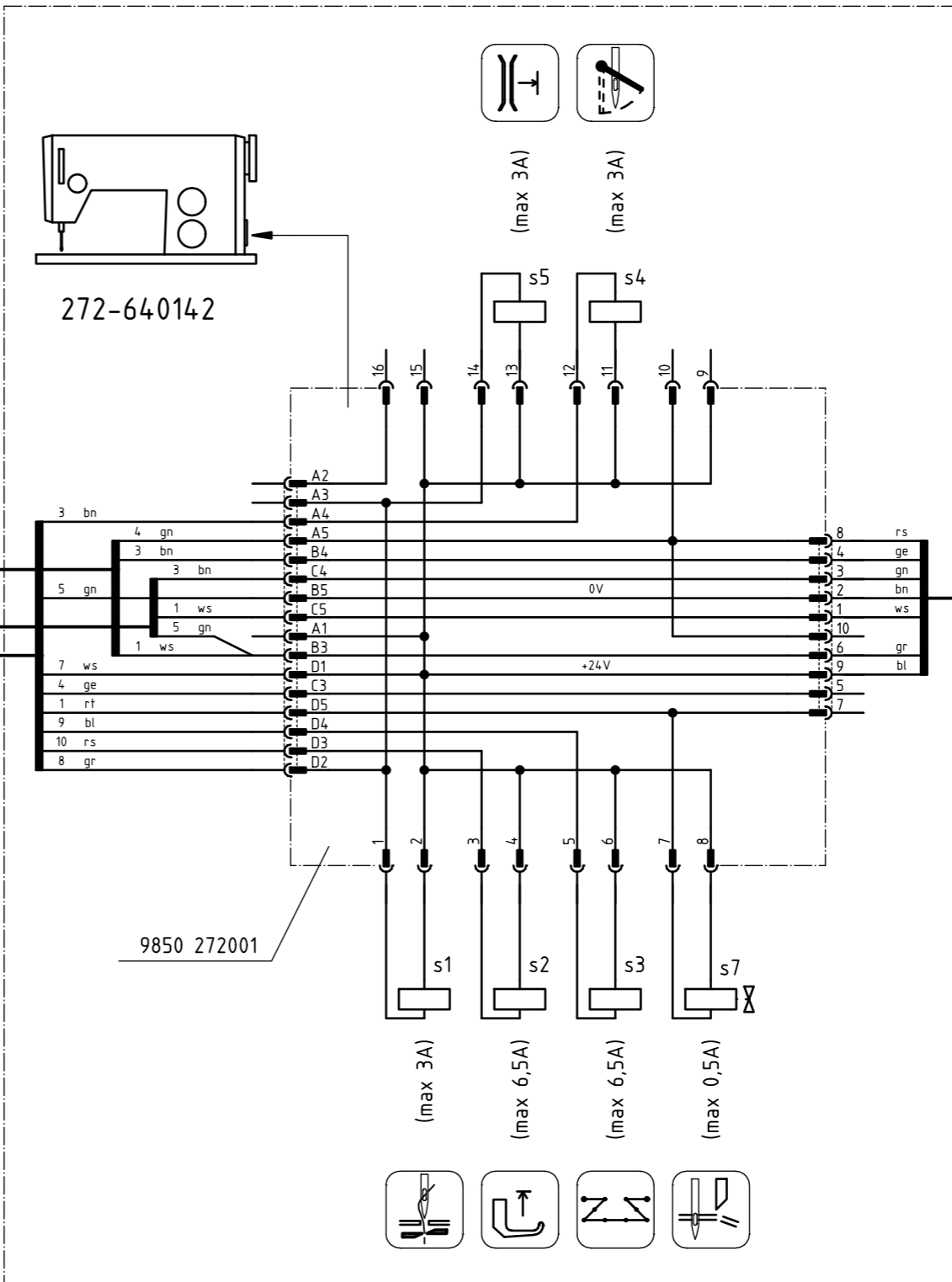
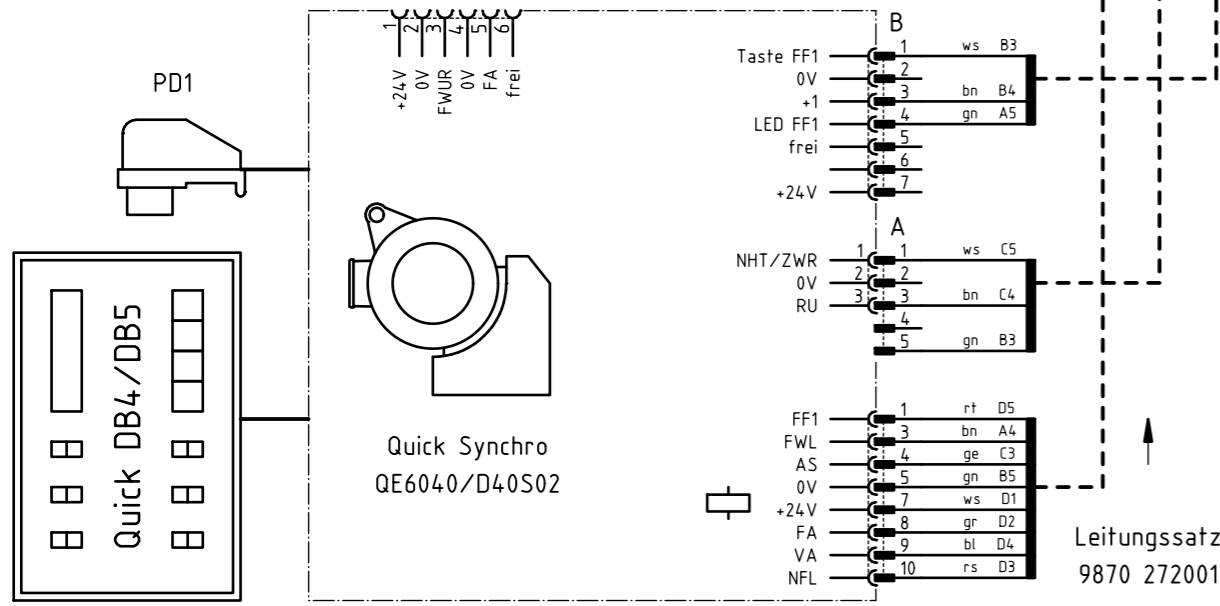
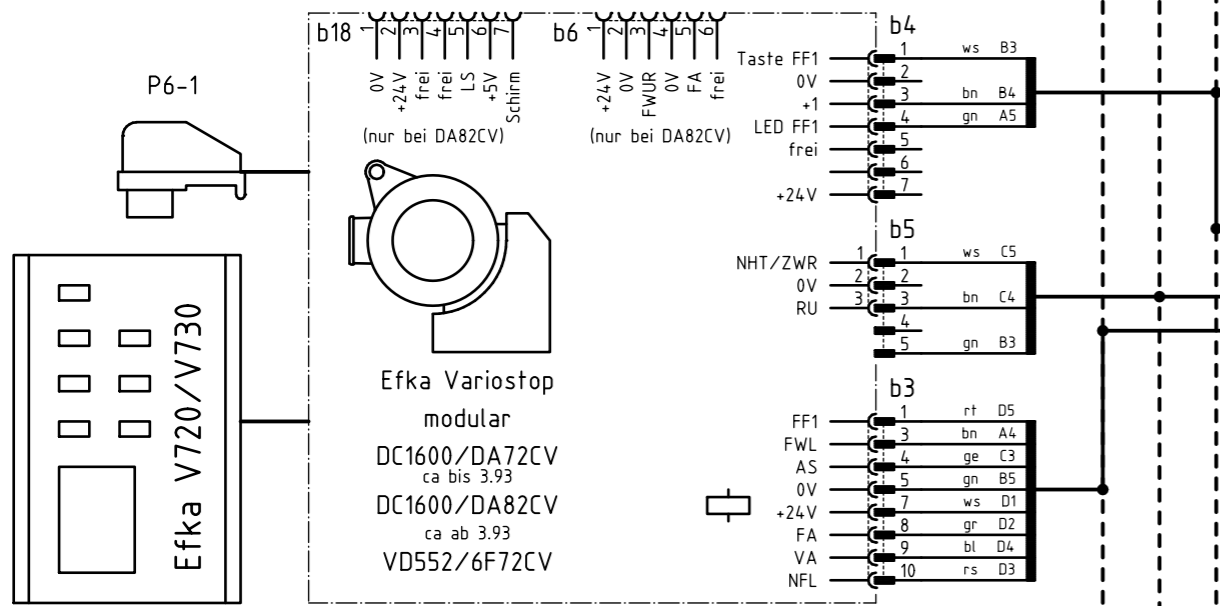
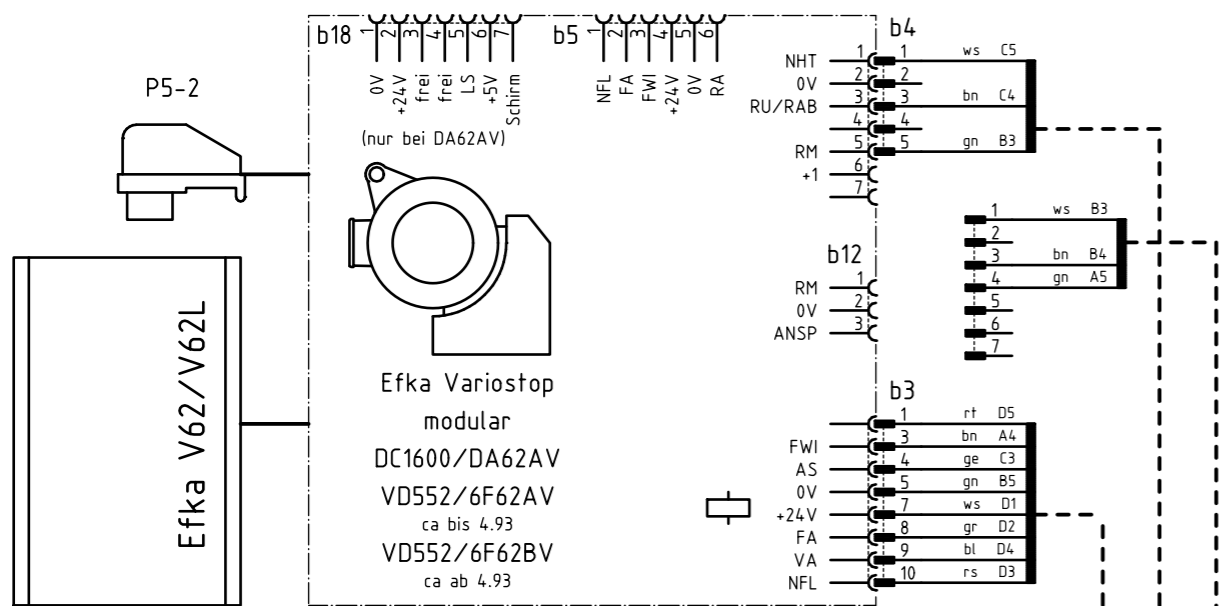

9850 272001

Leitungssatz  
9870 272001

c			Datum	04.12.91
b	02.0	06.04.93	Krüger	Bearb. Krüger
a	01.0	17.08.92	Krüger	Gepr.
	Anderung	Datum	Name	Norm



**DÜRKOPP ADLER AG**  
Bielefeld

Teilefamilie	272-640142
Freigabe	152 / 91

**Bauschaltplan**  
9890 272001 B

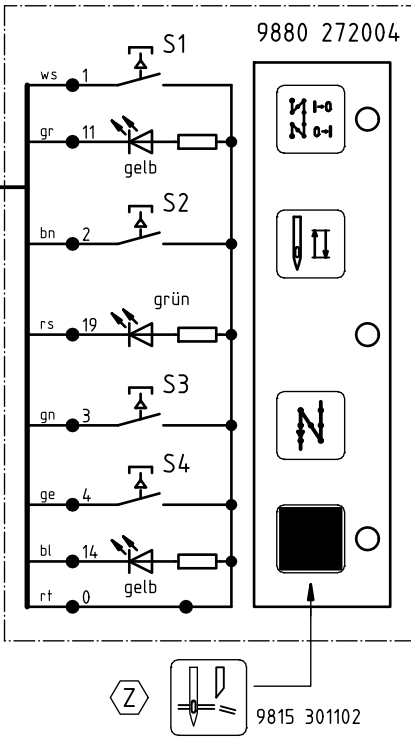
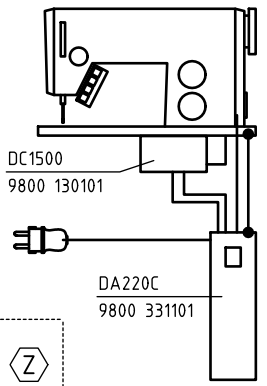
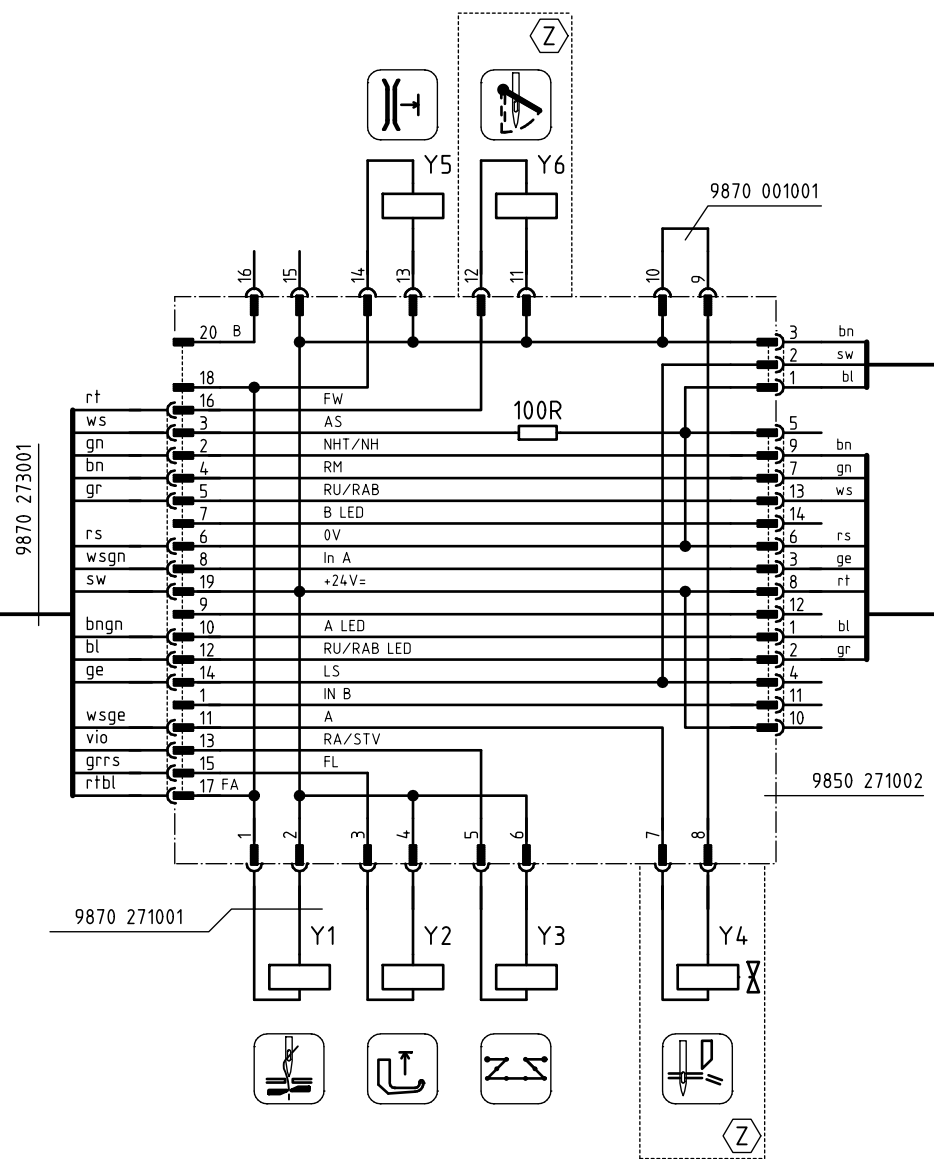
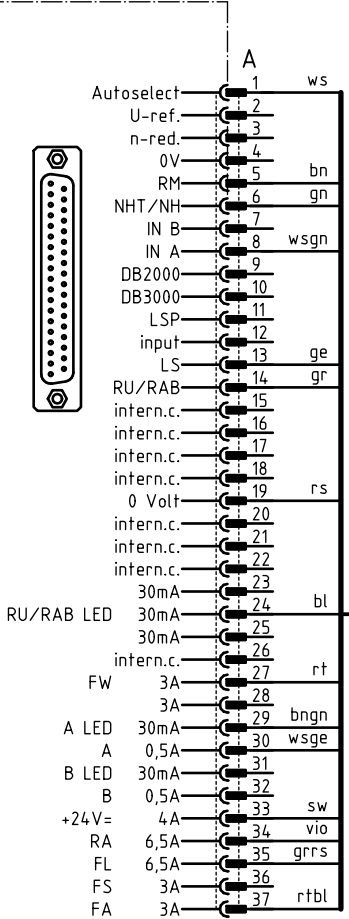
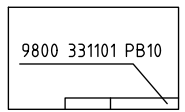
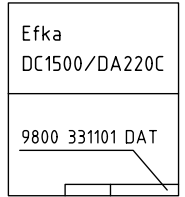
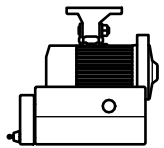

(Z) = auf Wunsch/on request

c			Datum	20.04.99
b			Bearb.	Hd
a			Gepr.	
	Änderung	Datum	Name	Norm

DÜRKOPP  
ADLER AG  
Bielefeld

Teilfamilie  
Freigabe  
1306 / 98

272-640642

Bauschaltplan  
9890 272003 B

Blatt  
1/1

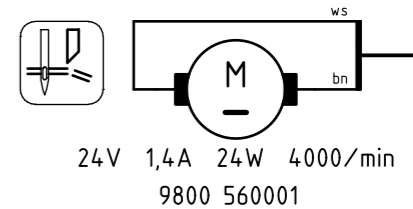
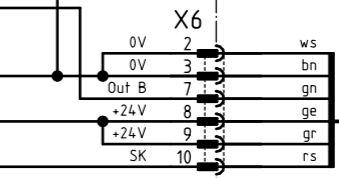
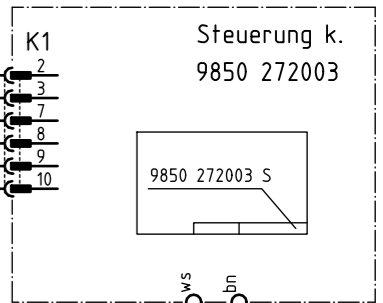
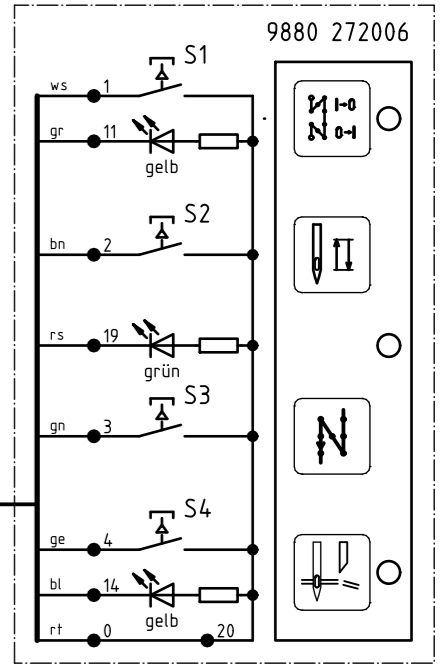
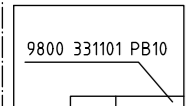
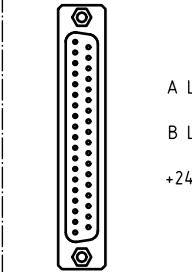
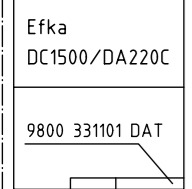
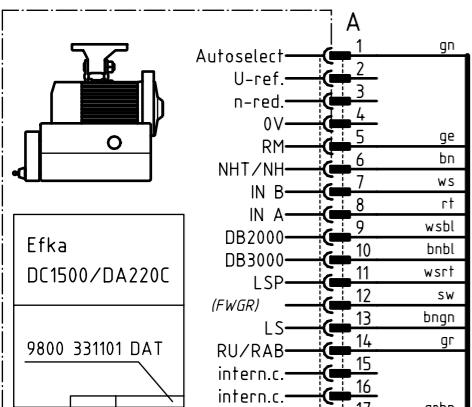
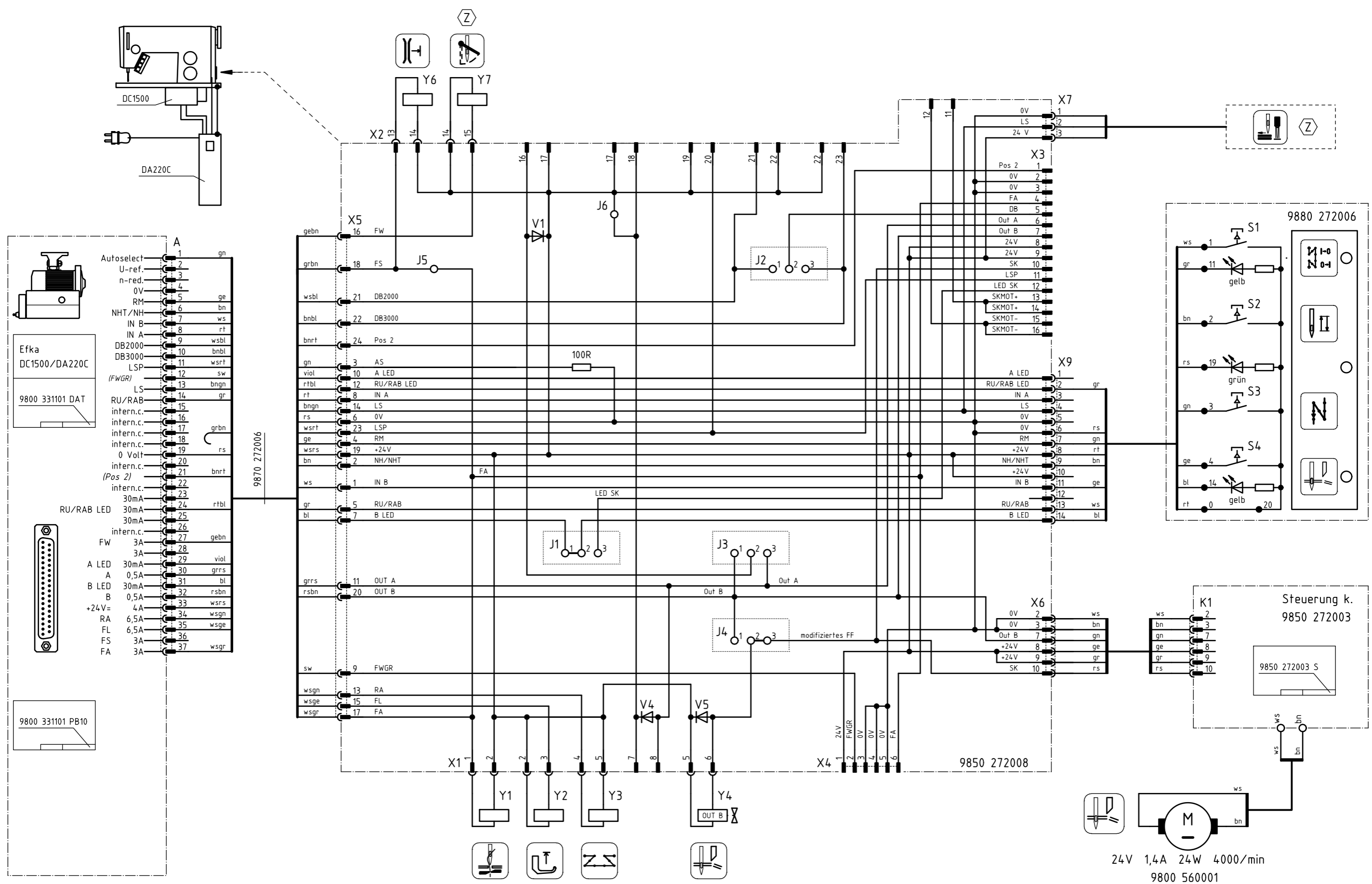

(Z) = auf Wunsch/on request

c			Datum	16.04.99
b			Bearb.	Hd
a			Gepr.	
	Anderung	Datum	Name	Norm



Teilfamilie	272-740642
Freigabe	1306 / 98

272-740642

Bauschaltplan  
9890 272004 B

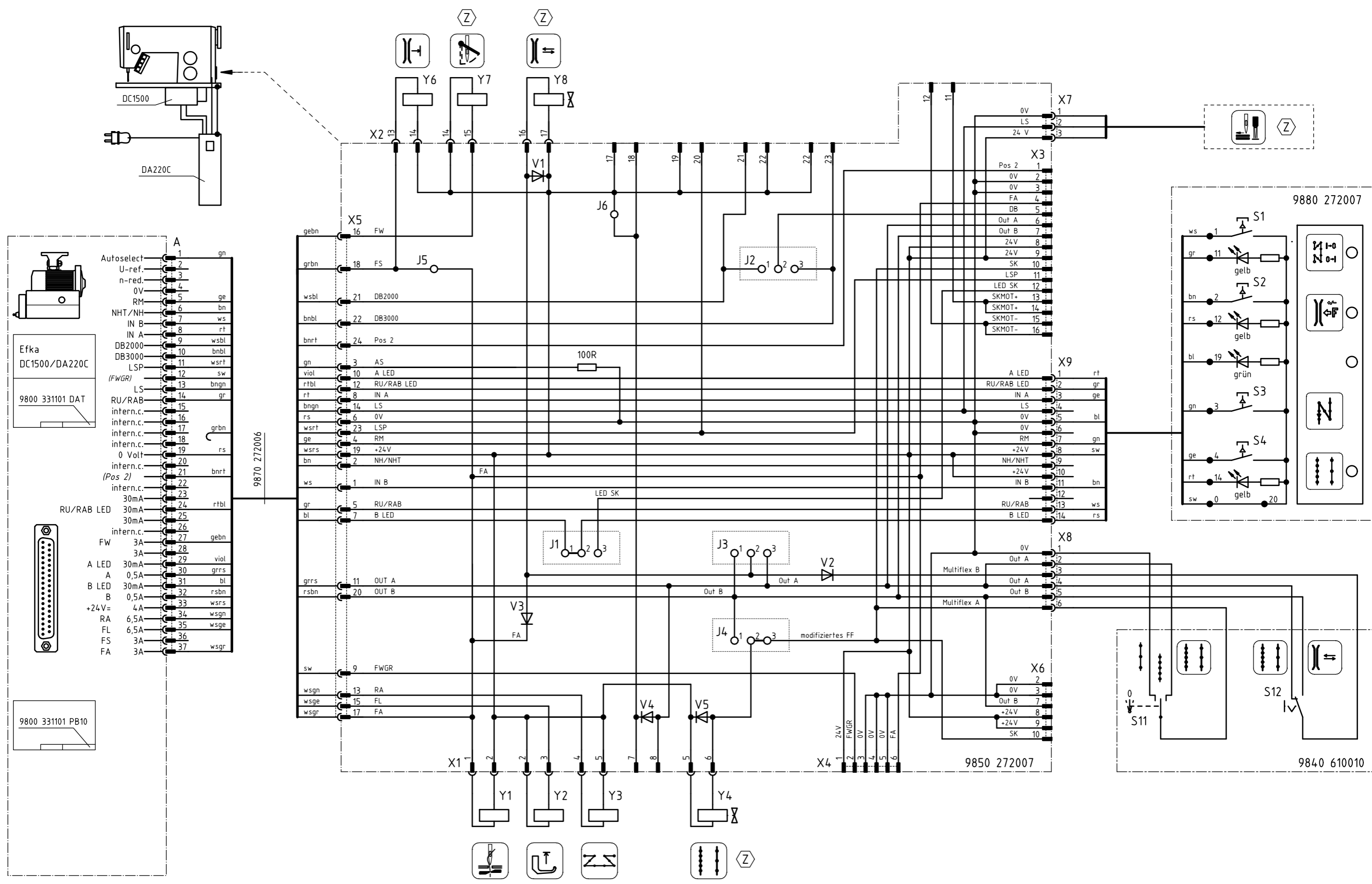

(Z) = auf Wunsch/on request

c			Datum	15.04.99
b			Bearb.	Hd
a			Gepr.	
	Änderung	Datum	Name	Norm



Teilefamilie  
Freigabe  
1306 / 98

272-160362 mit Multiflex  
Bausatz 0272 590014  
Kit 0272 590014

Bauschaltplan  
9890 272005 B

Blatt  
1/1

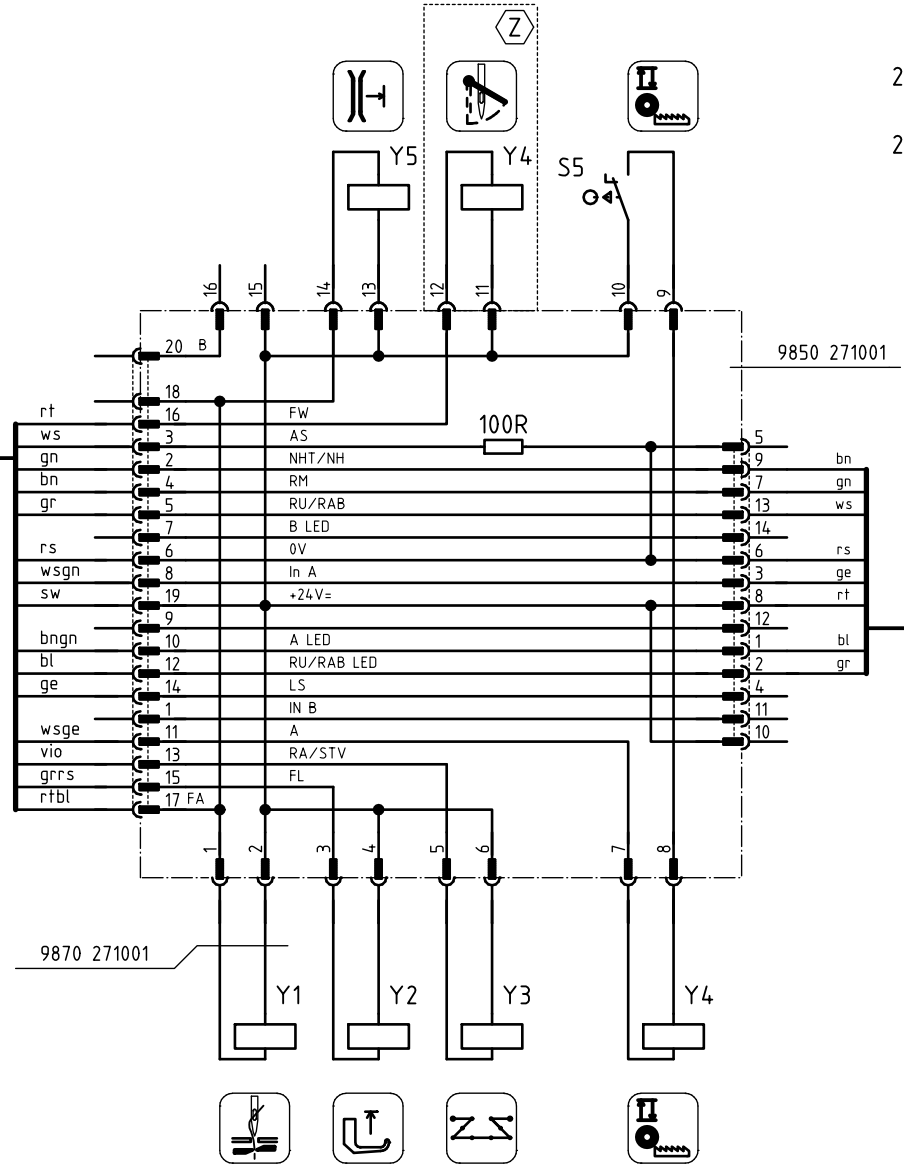
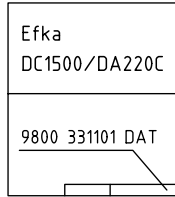
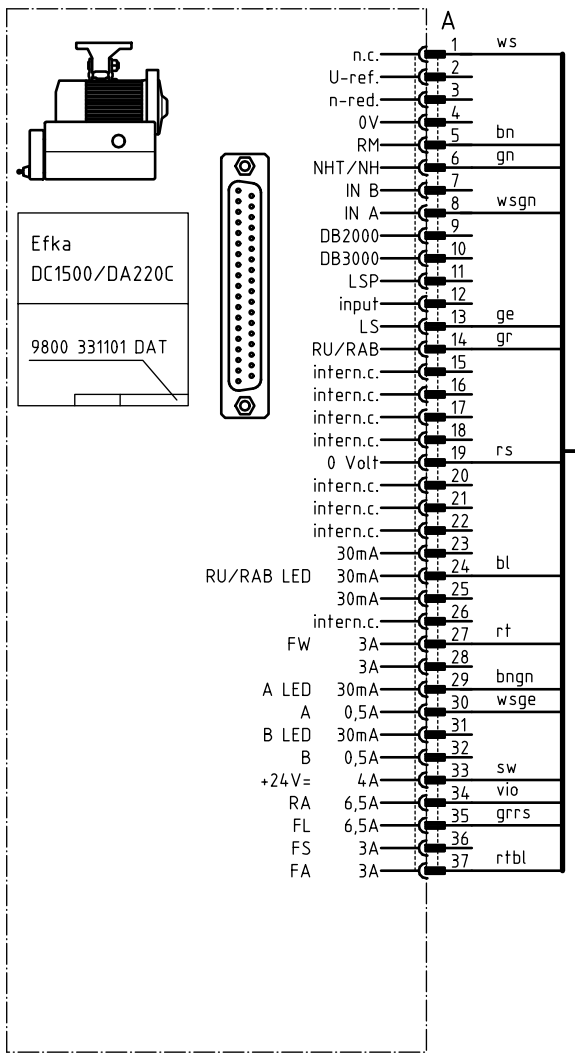

273-140342  
274-140342

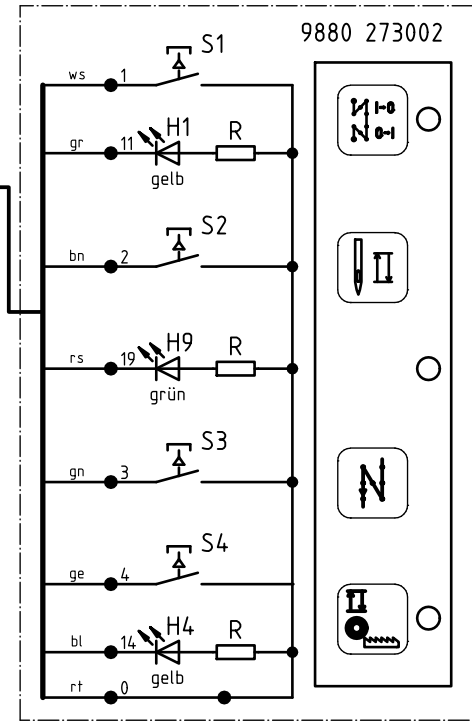
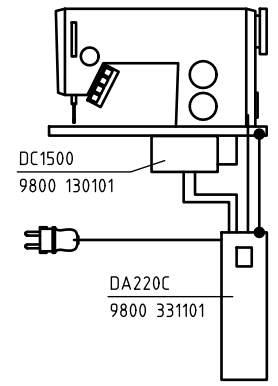

(Z) = auf Wunsch/on request

c			Datum	13.10.98
b			Bearb.	RE
a			Gepr.	
	Änderung	Datum	Name	Norm



Teilfamilie  
Freigabe  
1037 / 98

273-140342, 274-140342  
mit Näh Antrieb 9800 130101 R  
with sewing motor 9800 130101 R

Bauschaltplan  
9890 273002 B

Blatt  
1/1

**Klasse/Class 272-140342-01**

<b>Nr./No.</b>	<b>Teilenummer/ part number</b>	<b>Menge/ Quantity</b>	<b>Bezeichnung</b>	<b>Description</b>
1	0271 150124	1	Greifer	Hook
2	0281 150084	1	Spulengehäuseoberteil	Bobbin case
3	0271 001483	1	Hakenmesser	Curved knife
4	0271 001497	1	Messer	Knife
5	0204 000230 A	5	Spule	Bobbin
6	0271 000197	1	Anzugsfeder	Spring
7	0211 001127	1	Spannungsfeder	Tension spring
8	0556 000148	10	Gewindestift	Threaded pin
9	0570 001252	10	Senkschraube	Sunk screw
10	0211 001129	10	Zylinderschraube	Screw
11	0211 001107	10	Senkschraube	Sunk screw
12	0291 000159	1	Fadenführung	Thread guide
13	0004 000079	1	Spannungsfeder	Tension spring
14	0271 000199	1	Stegscheibe	Disc
15	0216 000591	1	Frikitionsbelag	Friction coatings
16	0216 000134	10	Senkschraube	Sunk screw
17	0216 000131	10	Zylinderschraube mit Zapfen	Cylinder screw
18	0271 000756	10	Gewindestift	Threaded pin
19	0933 063984	10	Linsenschraube	Screw
20	0211 050214	1	Spannungsscheibe	Tension washer

**Klasse/Class 272-160362-01**

<b>Nr./No.</b>	<b>Teilenummer/ part number</b>	<b>Menge/ Quantity</b>	<b>Bezeichnung</b>	<b>Description</b>
1	0271 002091	1	Greifer	Hook
2	0271 002105	1	Spulengehäuseoberteil	Winder head
3	0271 001483	1	Hakenmesser	Curved knife
4	0271 001497	1	Messer	Knife
5	0271 002103	5	Spule	Bobbin
6	0271 000197	1	Anzugsfeder	Spring
7	0271 002117	1	Spannungsfeder	Tension spring
8	0556 000148	10	Gewindestift	Threaded pin
9	0271 002119	10	Senkschraube	Sunk screw
10	0271 002118	10	Zylinderschraube	Cylinder screw
11	0992 017520	10	Linsensenkschraube	Screw
12	0291 000159	1	Fadenführung	Thread guide
13	0004 000079	1	Spannungsfeder	Tension spring
14	0271 000199	1	Stegscheibe	Disc
15	0216 000591	1	Friktionsbelag	Friction coatings
16	0216 000134	10	Senkschraube	Sunk screw
17	0216 000131	10	Zylinderschraube mit Zapfen	Cylinder screw
18	0271 002096	10	Zylinderschraube	Cylinder screw
19	0933 063984	10	Linsenschraube	Screw
20	0211 050214	1	Spannungsscheibe	Tension washer









**DÜRKOPP ADLER GmbH**

Potsdamer Straße 190

33719 Bielefeld

GERMANY

Phone +49 (0) 521 / 925-00

E-Mail [service@duerkopp-adler.com](mailto:service@duerkopp-adler.com)

[www.duerkopp-adler.com](http://www.duerkopp-adler.com)